

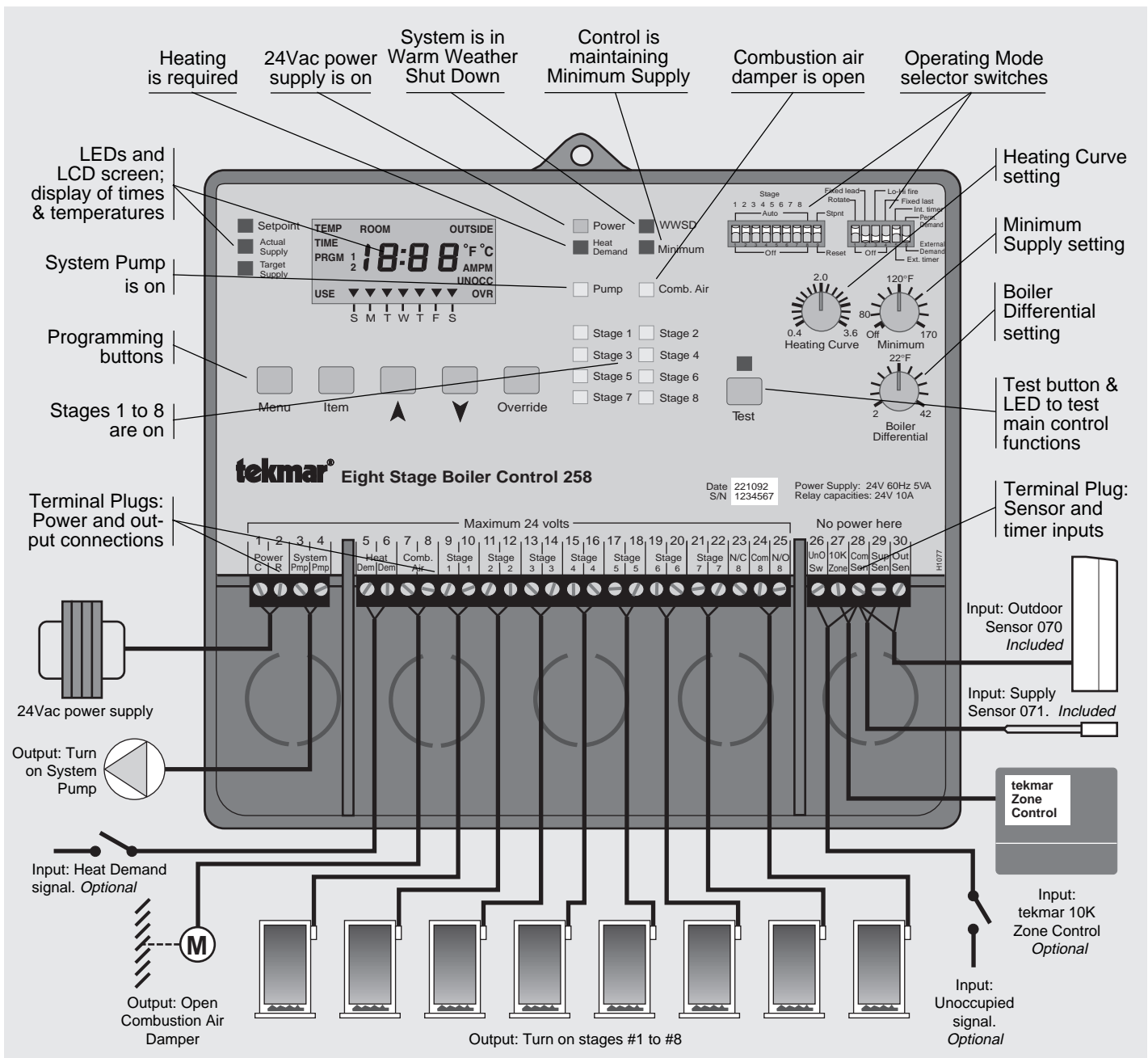

The tekmar Eight Stage Boiler Control 258 is a microprocessor-based control which regulates the supply water temperature from up to 8 boilers based on the outdoor air temperature, and optionally, the indoor air temperature through a tekmar 10K Zone Control. The System pump is turned on when there is a Heat Demand and the outdoor temperature is cool enough to require heat in the system. When a combustion air damper is used, it must be opened before the first boiler is fired. The control has a built-in setback timer and LCD screen to display temperatures and boiler running times.

Outdoor Reset Strategy	pg. 2	Error Messages	pg. 14
Sequence of Operation	pg. 4	Programming	pg. 15
Installation	pg. 7	Pre-Programmed Schedules	pg. 18
Settings	pg. 10	Technical Data	pg. 19
Testing	pg. 13	Limited Warranty	pg. 20



Outdoor Reset Strategy

Correct setting and shifting of the Heating Curve... the key to More Comfort and Energy Savings.

Heating Curve

As outdoor temperatures become colder, heat losses from a building increase and require the addition of more heat in order to prevent the indoor air temperature from becoming colder as a result. This tekmar reset control measures the outdoor temperature, and as the outdoor temperature becomes colder the control will balance the heat loss by making the heating supply water hotter.

The Heating Curve is used to calculate exactly how hot to make the supply water at different outdoor temperatures, as it determines the number of degrees the supply water temperature is raised for each degree the outdoor temperature falls.

Setting the Heating Curve

Two examples of how the Heating Curve works are illustrated in the following diagram.

—With a 2.4 Curve, the supply water temperature is raised 2.4 degrees for every degree of outdoor temperature drop.

If: WWSD point = 70°F and Outdoor temperature = 30°F, then supply temperature = 166°F

—With a 0.6 Curve, the supply water temperature is raised 0.6 degrees for every degree of outdoor temperature drop.

If: WWSD point = 70°F and Outdoor temperature = 30°F, then supply temperature = 94°F

- If the Heating Curve selected is too low; the heating system will not supply hot enough water to keep the room temperature warm, particularly during the colder weather.
- If the Heating Curve selected is too high; the supply water will be too hot for the conditions and the building will overheat, particularly during the colder weather.

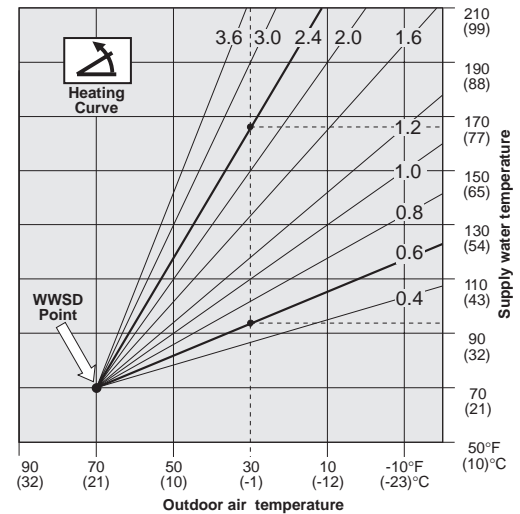

Warm Weather Shut Down (WWSD)

At warm outdoor temperatures, the indoor space of a building gains heat from the outdoors; additional heat is not required, and if the heating system is running (even on standby), enough excess heat can be produced to overheat the building, causing discomfort and wasting valuable energy. This control shuts off the boilers and system pump when the outdoor temperature is above the WWSD point.

As outdoor temperatures get colder, there comes a point where the heat gain turns into heat loss; the heat loss causes the indoor temperature to fall below the comfort level, and the heating system must be turned on.

To provide heat to the building, this control opens the combustion air damper (if one is used), turns on the system pump and fires the boilers to deliver heat at the low output required by the Heating Curve near the WWSD point. If the outdoor temperature rises above the WWSD point, the control shuts the heating system off again, and since the system was operating at a low heat output level, overheating and temperature swings in mild weather are avoided.

When the outdoor temperature is near the WWSD point and the building is too cold; the WWSD point should be raised.
When the outdoor temperature is near the WWSD point and the building is too warm; the WWSD point should be lowered.

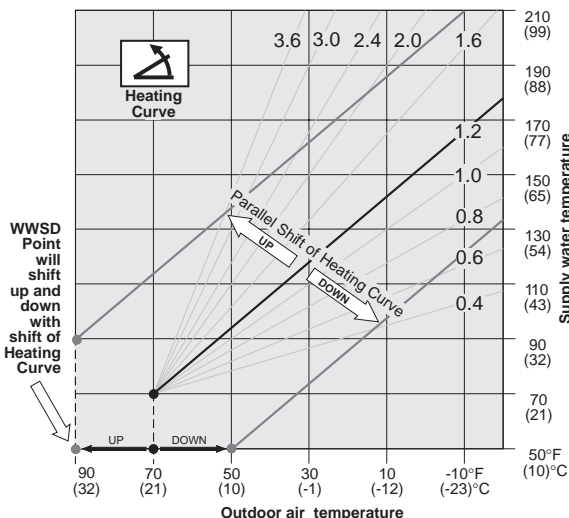

Shifting the Heating Curve

(a) Manually, at the control:

The Occupied and Unoccupied room temperature settings of this control can shift the WWSD point up or down from 35 to 105°F (2 to 41°C).

(b) Automatically, using room temperature feedback:

In addition to a Supply Sensor and an Outdoor Sensor, this control can use a tekmar 10K Zone Control to provide room temperature feedback for added comfort and system flexibility.

The control still calculates a desired supply temperature based on the Heating Curve setting and the outdoor temperature.

If the air temperature in any one zone is too cold, the control will shift the Heating Curve (and WWSD point) up, which raises the supply temperature until the zone warms up again. The zone control will operate zone valves or pumps in the warm zones to prevent overheating in those zones.

If the air temperature in all zones is too warm, the control will shift the Heating Curve (and WWSD point) down, which lowers the supply temperature until the zones cool down.

A very cool zone temperature can shift the curve far enough up to bring the control out of WWSD at warm outdoor temperatures. Very warm zone temperatures can shift the curve far enough down to put the control into WWSD at cool outdoor temperatures.

Refer to the tekmar Essays E 001 and E 002 for more detailed information regarding control strategy and integration of control functions.

Notes on the operation of a PID control and the effect of the PID processing function on target temperature calculations and control response to temperature change.

In order to reduce excessive temperature droop or overshoot and more smoothly stage the boilers on and off, this control uses an advanced Proportional + Integral + Derivative processing algorithm to calculate target temperatures. When a desired temperature – such as a setpoint – is programmed into the control, the control will initially use that setting as the exact target temperature. The PID function however, can affect the calculation of the target temperature in two significant ways. As an example; when there is a *rapid increase* in the actual temperature (Derivative), the control will calculate a lower target temperature than the setpoint in order to slow down or reverse the staging on of the boilers or; when the actual temperature *remains above* the setpoint for a long period of time without changing (Integral), the control will calculate a lower target temperature in order to more quickly stage the boilers off. Any change in the calculated target temperature will show up as a temporary deviation in the LCD target temperature display. The deviation in target temperature will be reduced as the actual temperature approaches the desired temperature. This display function can be a useful tool in troubleshooting system problems, and is discussed in more detail in other sections of this brochure.

The effect of the derivative function can easily be viewed when the "target temperature" fixed display is selected. Certain rapid

control adjustments will have a temporary effect on the target temperature. By quickly turning up the Heating Curve dial for instance, the operator will introduce enough derivative error to the control to drive the target temperature artificially high for a few seconds. This type of control response is no cause for alarm since the displayed target temperature will automatically return to normal when the dials are left alone for 20 seconds, as the control resets itself. This type of reaction to a sudden change illustrates an important point that should be considered when designing with PID controls. *Flow rate and system load changes should be made as slowly as possible in order to prevent overreaction by the control.*

The effect of the Integral function can also be easily viewed by not allowing a rise in supply temperature when the control asks for more heat. The displayed target temperature will show a slow but steady increase, illustrating another important point. *Whenever the control asks for a change in temperature – ie. stages a boiler on or off – the control sensor must be able to detect a change as soon as possible or it will operate too many boilers. (Do not install sensors on return lines).* If a multiple boiler system has adequate, continuous flow and slowly changing load conditions, the result will be very smooth staging, minimal temperature droop or overshoot and operating characteristics that will provide stable temperature control.

The 258 Display

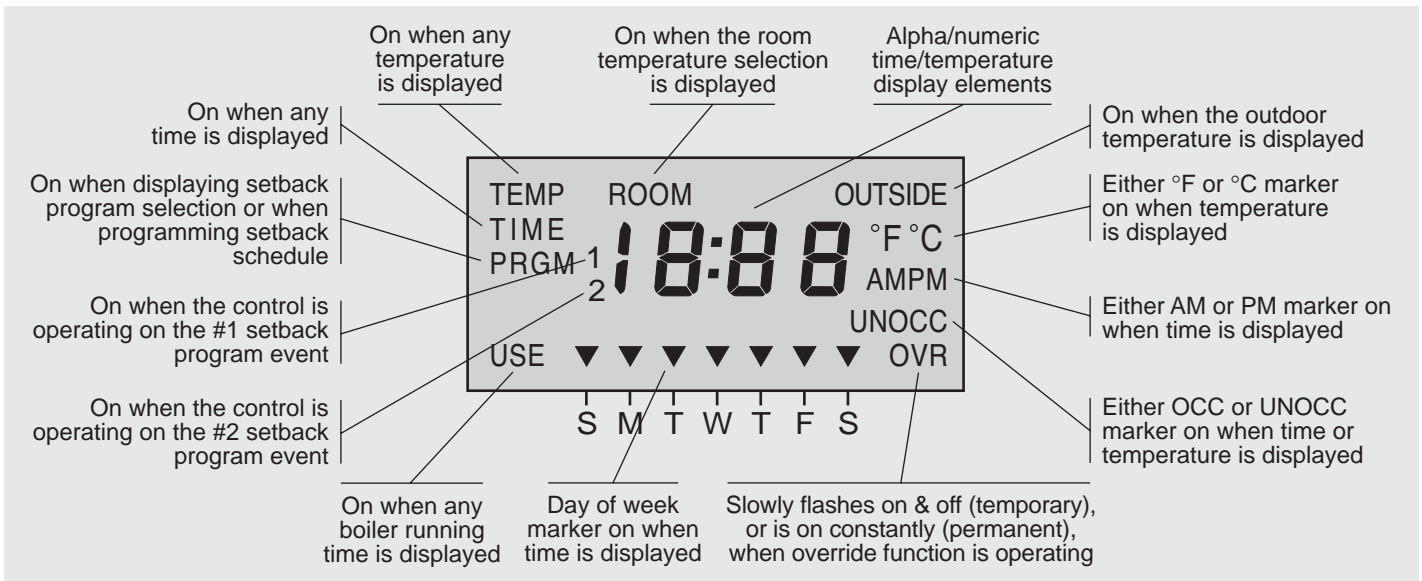

<p>ACTUAL SUPPLY – #1</p>	<p>Default fixed display. When first powered-up, or when other displays are allowed to "time-out", the control will constantly display the supply sensor temperature.</p>	<p>TARGET SUPPLY – #2</p>	<p>This fixed display shows the supply temperature that has been calculated by the control to meet the requirements of the Heating Curve or setpoint.</p>
<p>This fixed display shows the outdoor temperature sensor reading.</p>	<p>OUTDOOR TEMP. – #3</p>	<p>This fixed display shows the time of day, day of week and some of the current program operation information.</p>	<p>TIME/DAY – #4</p>

The 258 "Fixed display" options. All other displays will time-out to "ACTUAL SUPPLY – #1" after 20 seconds with no keypad action. See "Programming" Section, Pg. 15, for description

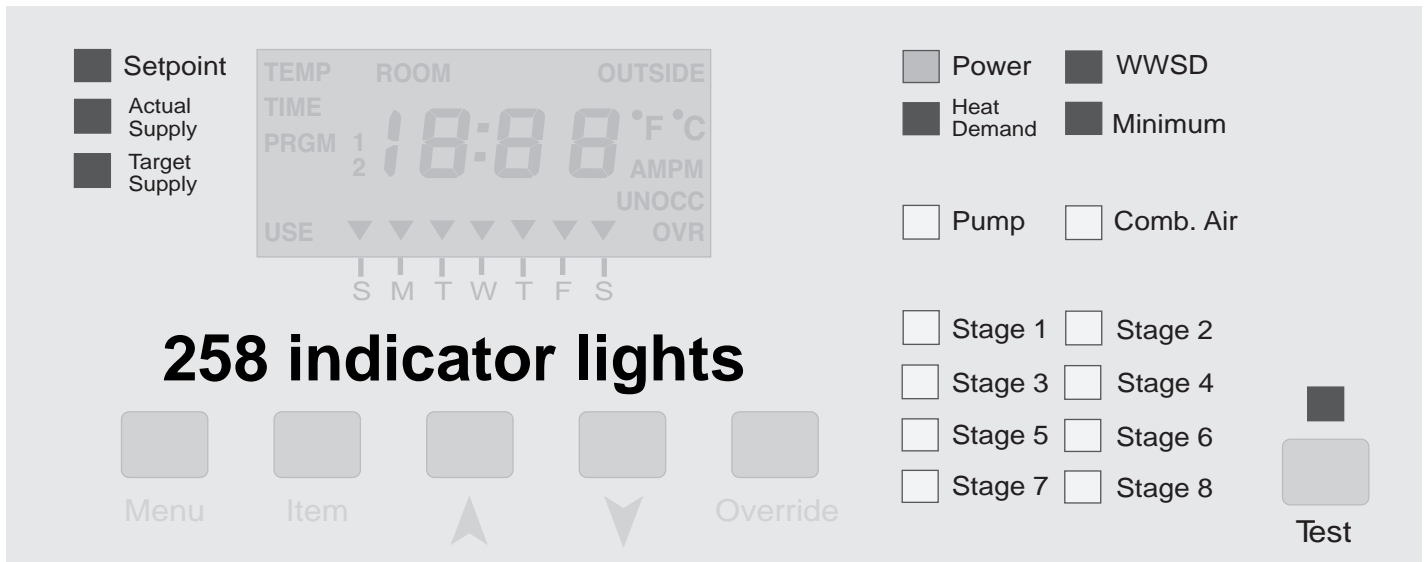

There are eighteen lights on the front of the control that will aid in testing and troubleshooting. During normal operation, these lights indicate the following functions:

- "Power" light on
 - the 24Vac power supply has been connected to terminals *Power C – R* (1 and 2), and is energized.
- "Setpoint" light on
 - the Display is showing the programmed setpoint temperature.
- "Actual Supply" light on
 - the Display is showing the current supply sensor temperature.
- "Target Supply" light on
 - the Display is showing the control's calculated target supply temperature.
- "Heat Demand" light on
 - the control is receiving a 24Vac external Heat/Setpoint Demand signal at terminals *Heat Dem* (5 and 6)
 - or** the Heat/Setpoint Demand selector switch is in the "Permanent" position **or** a 10K Zone Control is connected and is creating a Heat Demand.
- "WWSD" light on
 - the control is in the "Reset" mode, the outdoor temperature is above the WWSD point and the control has shut the heating system off.
- "Minimum" light on
 - the control has calculated that it must operate the boiler(s) to maintain the Minimum Supply temperature until the outdoor temperature is cold enough to allow Heating Curve operation.
- "System pump" light on
 - the system pump relay is on, closing the contacts between terminals *System Pmp* (3 & 4).
- "Comb. air" light on
 - the combustion air relay is on, closing the contacts between terminals *Comb. air* (7 & 8).
- "Stage 1 to 8" lights on
 - a boiler relay is on, closing the contacts between terminals *Stage 1* (9 & 10) , *Stage 2* (11 & 12), etc.
- "Test" light on/**flashing**
 - the control is going through the programmed test routine/**is halted in test routine.**

Sequence of Operation

When the Eight Stage Boiler Control 258 is powered-up, the "Power" light will come on and the full display along with all of the red temperature indicator lights are switched on for approximately 5 seconds. The Display will then default to show the "ACTUAL SUPPLY" fixed display mode and the control will enter the operating mode. A "fixed display" is one which will show its information continuously, and the four fixed displays available to the user are illustrated on the previous page. More information on access to displays and on programming is available in the "Programming" section, starting on page 15.

Once in operating mode, the control uses the Outdoor Sensor 070 to continually monitor the outdoor temperature, and the Universal Sensor 071 to continually monitor the system supply water temperature.

Indoor temperature can be monitored through the use of a tekmar 10K Zone Control (**Optional; must be ordered separately**)

While monitoring these temperatures, the control recognizes a variety of conditions and inputs, and will operate the system as described below. During operation, the lights on the front of the control – illustrated above – will indicate how the system is operating. By reading this sequence of operation section and comparing it to what the indicator lights and the L.C.D. display actually show; installers, end users and maintenance personnel can easily confirm proper system and control operation in the field and make the right corrective adjustments when necessary.

Heating Operation

The 258 control must have the *Reset/Stpnt* selector switch set for "Reset", and must receive a Heat Demand signal before it can operate in the heating mode.

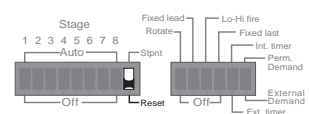

Heat Demand signal ———— Selector switch = External Demand

(a) - A Heat Demand signal is caused by either 24Vac applied to terminals *Heat Dem* (5 and 6), or a 10K Zone Control connected to terminals *10K Zone — Com Sen* (27 and 28), or both.

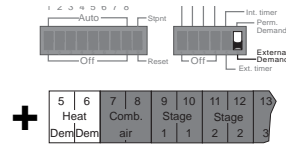

OR

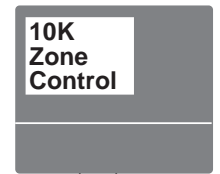

OR

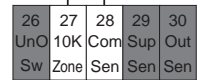

OR ———— Selector switch = Perm. Demand

(b) - A Heat Demand signal is either continuously present or; when a 10K Zone Control is connected, a heat demand signal is present only when the 10K Zone Control calls for heat.

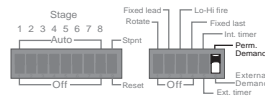

tekmar 10K Zone Control function

The control will monitor the indoor temperatures of all zones, as well as the outdoor and supply temperatures, and shift the Heating Curve (and the WWSD point) up or down to fine adjust the system supply water temperature for whichever zone requires the hottest supply water. The internal Occupied and Unoccupied programs of the 258 are not functional.

Occupied/Unoccupied Room Temperature function (no indoor temperature feedback)

The control will monitor the outdoor and supply temperatures. The Occupied or Unoccupied programmed room temperature settings become the WWSD points. When the outdoor temperature is warmer than the Occupied room temperature setting, the control enters WWSD. When switched into Unoccupied mode, the "UNOCC" display element will replace the "OCC" display element, and the control will switch from operating at the Occupied room temperature setting to operating at the Unoccupied room temperature setting.

Unoccupied mode

(a) – Unoccupied signal from the Internal timer

The DIP selector switch for the timer must be in the "Int. timer" position

When the control's Internal timer is active and a setback schedule is selected or programmed, the control will enter the Unoccupied mode based on the program of the setback schedule.

Timer programming instructions are on page 16

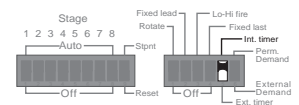

(b) - Unoccupied signal from an external source

The DIP selector switch for the timer must be in the "Ext. timer" position

Connect (short circuit) terminals *UnO Sw — Com Sen* (26 and 28) together.

The Unoccupied room temperature setting becomes active. Any dry contact closure may be used to switch into Unoccupied mode. **Caution, dry contact only, there should be no voltage present.**

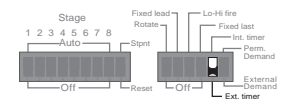

WWSD function

When WWSD occurs, the "WWSD" light will come on, and the control will continue to monitor the outdoor temperature, supply temperature and – if a 10K zone control is connected – indoor temperature. Whenever 3 days pass with the control in uninterrupted WWSD, the pump will be cycled on for 20 seconds to help prevent it from seizing up. **Caution: This control may start the pump at any time. An approved, accessible electrical disconnect must be installed to allow safe maintenance procedures.**

Outdoor temperature cold enough to require heating

No heat demand signal

When the outdoor temperature is colder than the WWSD point, the control will leave WWSD. Whenever the control leaves WWSD, the "WWSD" light will turn off and the control will continue to monitor the outdoor temperature, supply temperature and indoor temperature (optional), but no further control action will take place until there is a Heat Demand signal.

The outdoor temperature will be continuously displayed if the "Outside Temperature" fixed display is selected.

With Heat demand signal

The "Heat Demand" and "Pump" lights will come on, the control will operate the system pump and calculate the target supply temperature based on the requirements of the Heating Curve or the Minimum Supply setting, whichever is highest.

The "Target Supply" light will turn on and the target temperature will be continuously displayed if the "Target Supply" fixed display is selected.

With boiler minimum setting higher than heating curve requirement

The "Minimum" and "Comb. air" lights will come on and the control will wait for 60 seconds (to ensure that the combustion air damper has had enough time to open). One or more "Stage" lights will come on and the control will stage on the boilers based on its PID calculations. The boilers will fire until the supply temperature reaches the minimum setting plus the differential setting. When this point is reached, the control will stage off the boilers based on its PID calculations and the "Stage" and "Comb. air" lights will be shut off with the boilers and combustion air damper. The "Minimum" light will stay on and the control will continue to cycle the boilers and combustion air damper to maintain the supply temperature at the Minimum setting.

The "Actual Supply" light will turn on and the supply temperature will be continuously monitored when the control is set for the "Actual Supply" fixed display.

Outdoor temperature cold enough for heating curve operation

The " Comb. air" light will come on and the control will wait for 60 seconds (to ensure that the combustion air damper has had enough time to open). One or more "Stage" lights will come on and the control will stage on the boilers based on its PID calculations. The boilers will fire until the supply temperature reaches the heating curve target temperature plus one half the Boiler Differential setting. When this point is reached, the control will stage off the boilers based on its PID calculations and the "Stage" and "Comb. air" lights will be shut off with the boilers and combustion air damper. The control will continue to cycle the boilers and combustion air damper to maintain the supply at the target temperature.

Note: Whenever the boilers are turned off, the control will keep them off until at least the minimum time delay has expired (1 minute to 5 minutes depending on degree of error).

Setpoint Operation (DIP selector switch must be in "Stpnt" position)

The 258 control must have the Reset/Stpnt selector switch set for "Stpnt", and must receive a heat demand signal before it can operate in the setpoint mode. When used for setpoint operation, the outdoor sensor has no function and need not be installed. The "Outdoor Temperature" fixed display will show a null display (— —).

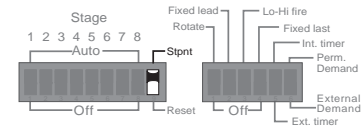

Setpoint Demand signal ————— Selector switch = External Demand

A Setpoint demand signal is caused whenever 24Vac is applied to terminals Heat Dem (5 and 6).

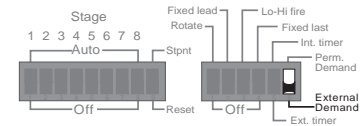

OR ————— Selector switch = Perm. Demand

A Setpoint demand signal is continuously present.

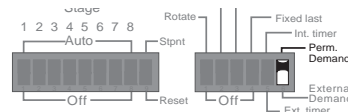

Occupied/Unoccupied Setpoint Operation

The control will monitor the supply temperature. The Occupied or Unoccupied programmed setpoint temperature settings become the target temperatures. When switched into Unoccupied mode, the "UNOCC" display element will replace the "OCC" display element, and the control will switch from operating at the Occupied setpoint temperature setting to operating at the Unoccupied setpoint temperature setting. Refer to the "Programming" section on page 15 for details on setting setpoint temperatures.

No Setpoint Demand signal

The control is essentially "on standby" at this point. The internal timer – if used – will continue to operate its various functions, but no action will take place until a demand signal is present. Error messages will be displayed if an error occurs during this mode. Refer to page 14 for a list of Error messages and their explanation.

When a Setpoint Demand signal is present

When switched into operating mode by a Setpoint Demand signal, the "Heat Demand" and "Pump" lights will come on and the control will switch on the system pump. If the supply temperature is at least one half the Boiler Differential setting lower than the Setpoint setting, The " Comb. air" light will come on and the control will wait for 60 seconds (to ensure that the combustion air damper has had enough time to open). One or more "Stage" lights will come on and the control will stage the boilers on based on its PID calculations. The boilers will fire until the supply temperature reaches the setpoint target temperature plus one half the Boiler Differential setting. When this point is reached, the control will stage off the boilers based on its PID calculations, and the "Stage" and "Comb. air" lights will be shut off with the boilers and combustion air damper. The control will continue to cycle the boilers and combustion air damper to maintain the supply at the setpoint target temperature until the Setpoint Demand signal is removed.

Unoccupied mode

(a) – Unoccupied signal from the Internal timer

The DIP selector switch for the timer must be in the "Int. timer" position. When the control's Internal timer is active and a setback schedule is selected or programmed, the control will enter the Unoccupied mode based on the program of the setback schedule.

Timer programming instructions are on pages 16 & 17

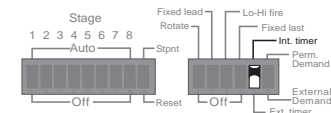

(b) – Unoccupied signal from an external source

The DIP selector switch for the timer must be in the "Ext. timer" position. Connect (short circuit) terminals UnO Sw — Com Sen (26 and 28) together. The Unoccupied room temperature setting becomes active. Any dry contact closure may be used to switch into Unoccupied mode.

Caution, dry contact only, there should be no voltage present.

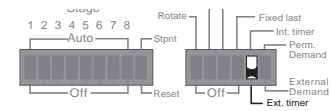

Installation

Caution: Improper installation and operation of this control could result in damage to equipment and possibly even personal injury. It is your responsibility to ensure that this control is safely installed according to all applicable codes and standards.

Step One ■■■■■ Getting ready ■■■■■

Check the contents of this package. If any of the contents listed are missing or damaged, please refer to the Limited Warranty and Product Return Procedure on the back of this brochure and contact your Wholesaler or tekmar Sales Agent for assistance.

Type 258 includes:

- One Control 258 • One Outdoor Sensor 070 • One Universal Sensor 071
- One Universal Sensor Enclosure 080 • One Data Brochure D 258 • One Data Brochure D 001
- One Application Brochure A 258

Other information available: • Essay E 001 • Essay E 002

Read Application Brochure A 258 and select the correct Application for your job.

Note: Carefully read the details of the Application, and the Sequence of Operation sections in all applicable brochures to ensure that you have chosen the proper control, and you understand its functions within the operational requirements of your system.

Step Two ■■■■■ Mounting the base ■■■■■

The control should be removed from its base by pressing down on the release clip in the wiring chamber and sliding upwards on the control. The base is then mounted in accordance with the instructions in the Data Brochure D 001.

Step Three ■■■■■ Rough-in Wiring ■■■■■

All electrical wiring terminates in the control base wiring chamber. It has standard 7/8" (22mm) knock-outs that will accept common wiring hardware and conduit fittings. Before breaking out the knock-outs, check the wiring diagram and select those sections of the chamber with common voltages, since the safety dividers will later prevent wiring from crossing between sections. Standard 18 to 22AWG solid wire is recommended for all low voltage wiring to tekmar controls. Heavier gauge wire may not fit properly into the terminal plugs, while lighter gauge wire is too fragile and may also contribute too much resistance to the circuit.

Power should not be applied to any of the wires, during this rough-in wiring stage.

- Install the Outdoor Sensor 070, and the Universal Sensor 071 according to the instructions in the Data Brochure D 001 and run the wiring back to the control.

Option: A 10K tekmar Zone Control can also be connected (**purchased separately**).

- Install the wiring from other system components; Boiler(s), Pump relay, Heat Demand **or** Setpoint Demand circuits to the base.
- Install a 24Vac Class II transformer with a minimum 5VA rating close to the control, and run the wiring from the transformer to the base. *A Class II transformer must be used. Do not connect any of the transformer terminals to ground.*

Step Four ■■■■■ Electrical connection to the control ■■■■■

Power and output connections

The installer should test to confirm that no voltage is present at any of the wires.

Install the control into the base, sliding it down until it snaps into place.

All electrical connections are made directly to the terminal plugs.

Connect the 24Vac power supply from the secondary side of a 24Vac Class II transformer to terminals *Power C — R* (1 and 2). *Do not connect either of the transformer terminals to ground.*

Maximum 24 Volts

1	2	3	4
Power		System	
C	R	Pmp	Pmp

Connect the system pump circuit to terminals *System Pmp* (3 and 4). These terminals lead to a 10 amp dry relay contact which closes when the control requires system pump operation.

Note: The 258 is approved for low voltage only (Maximum 24Vac). The system pump must be switched through an isolation relay approved for the line voltages required to operate the pump.

1	2	3	4
Power		System	
C	R	Pmp	Pmp

Connect the combustion air damper circuit to terminals *Comb. air* (7 and 8). These terminals lead to a 10 amp dry relay contact which closes when the control requires combustion air damper operation.

Note: The 258 is approved for low voltage only (Maximum 24Vac). If the combustion air damper operates on line voltage, it must be switched through an isolation relay.

5	6	7	8	9	10	11	12	13
Heat		Comb.		Stage		Stage		
Dem	Dem	Air		1	1	2	2	3

Connect the stage 1 boiler circuit to terminals *Stage 1* (9 and 10). These terminals lead to a 10 amp dry relay contact which closes when the control requires boiler operation. Repeat this step with the correct terminals for each additional stage. Boilers with 24Vac control circuits can be switched directly through the control. **If higher voltages are used, isolation relays must be added.**

8	9	10	11	12	13	14	15	16	17	18	19	20	21	22	23	24	25
b.	Stage 1		Stage 2		Stage 3		Stage 4		Stage 5		Stage 6		Stage 7		N/C	Com	N/O
	1	1	2	2	3	3	4	4	5	5	6	6	7	7	8	8	8

Powered input connections

If a 24Vac external *Heat Demand* signal is used, (zone valve end switches, etc.) connect the wiring from the Heat Demand circuit to terminals *Heat Dem* (5 and 6). When 24Vac is applied to these terminals, the control will recognize a "call for heat" from the system. **DIP switch must be set to "Reset"**

5	6	7	8	9	10	11	12	13
Heat Dem		Comb. air		Stage 1		Stage 2		3

If a 24Vac *Setpoint Demand* signal is used, (aquastat, etc.) connect the wiring from the Setpoint Demand circuit to terminals *Heat Dem* (5 and 6). When 24Vac is applied to these terminals, the control will recognize a "call for Setpoint temperature" and switch into Setpoint mode. **DIP switch must be set to "Stpnt"**

Sensor and unpowered input connections

Power should never be applied to these terminals. Damage to the control will result.

Do not apply power here!

Connect the two wires from the Outdoor Sensor 070 to terminals *Com Sen* — *Out Sen* (28 and 30).

26	27	28	29	30
UnO Sw	10K Zone	Com Sen	Sup Sen	Out Sen

Connect the two wires from the Supply Sensor 071 to terminals *Com Sen* — *Sup Sen* (28 and 29).

26	27	28	29	30
UnO Sw	10K Zone	Com Sen	Sup Sen	Out Sen

Option: Indoor temperature feedback, tekmar 10K Zone Control Only

Connect the two wires from a tekmar 10K Zone Control to terminals *10K Zone* — *Com Sen* (27 and 28).

26	27	28	29	30
UnO Sw	10K Zone	Com Sen	Sup Sen	Out Sen

Option: Occupied/Unoccupied switch input, when not using Internal timer

Connect the two wires from the Occupied/Unoccupied dry contact switch (timer, relay, etc.) to terminals *UnO Sen* — *Com Sen* (26 and 28).

26	27	28	29	30
UnO Sw	10K Zone	Com Sen	Sup Sen	Out Sen

Electrical connections to the terminal plugs of the 258 control. Control relays are shown in "power down" condition.

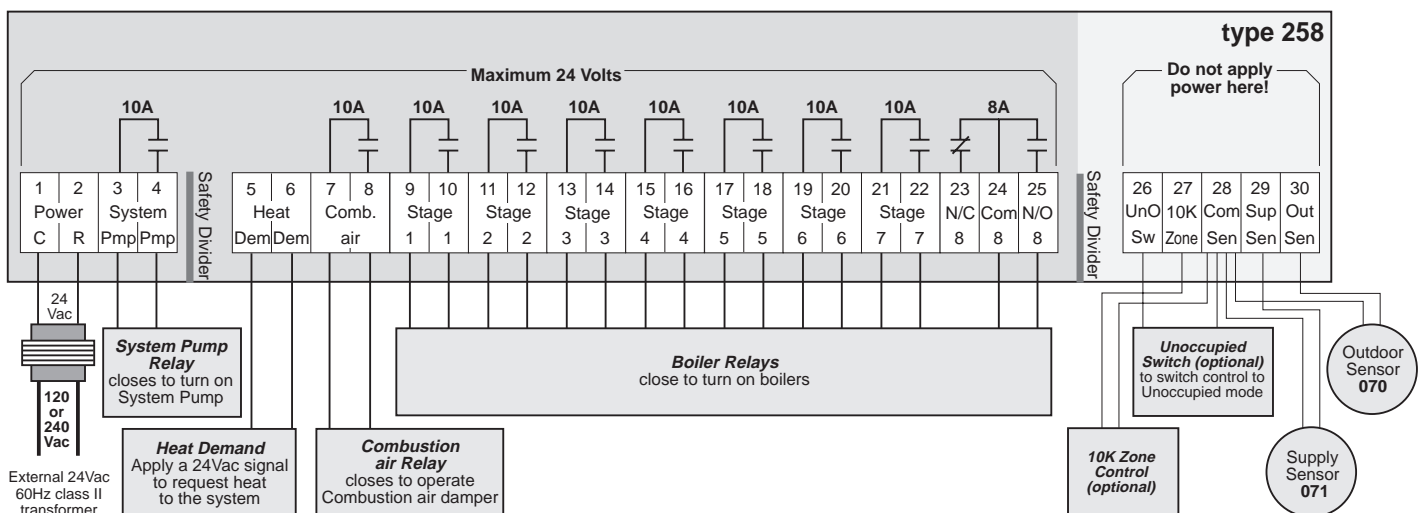

Note: This is not a Wiring Diagram. For a detailed wiring schematic of your specific application, refer to the Application Brochure A 258.

Step Five ■■■■ Testing the wiring ■■■■

Caution

- These tests are to be performed using standard testing practices and procedures and should only be carried out by properly trained and experienced persons.
- Before applying power to the control for testing, each terminal plug must be unplugged from its header on the control. Pull straight down to unplug.
- A good quality electrical test meter, capable of reading from at least 0 — 200 Volts AC, and at least 0 — 1,000,000 Ohms, is essential to properly test this control.

Test the sensors

- These tests must be made *before* turning on the power supply, and with the terminals unplugged.
- The sensors are to be tested according to the instructions in Brochure D 001.

Test the power supply

Make sure exposed wiring or bare terminals are not in contact with any other wires or grounded surfaces. Turn on the power to the transformer and use an AC voltmeter to measure the voltage between terminals *Power C — R* (1 and 2). 22 to 26 Volts AC should be measured at these terminals.

Test the powered inputs

If an external Heat Demand or Setpoint Demand signal is used, power up the Heat or Setpoint Demand circuit and supply a Demand signal to the control. Use an AC voltmeter to measure the voltage between terminals *Heat Dem* (5 and 6). 22 to 26 Volts AC should be measured at these terminals.

If a system pump circuit is connected to the *System Pmp* (3 and 4) terminals; make sure power to the circuit is off and install a jumper in the terminal plug between terminals (3 and 4). When the circuit is powered-up, the pump should operate. If it does not come on, check the circuit wiring for errors and ensure that it is powered up and the voltage is correct. Check the devices in the circuit (pump, switching relay, etc.) for faults. If the pump operates properly when the circuit is powered up, disconnect the power, remove the jumper and proceed to the next step.

If a combustion air damper circuit is connected to the *Comb. Air* (7 and 8) terminals; make sure power to the circuit is off and install a jumper in the terminal plug between terminals (7 and 8). When the circuit is powered-up, the combustion air damper should operate. If it does not come on, check the circuit wiring for errors and ensure that it is powered up and the voltage is correct. Check the devices in the circuit (damper motor, switching relay, etc.) for faults. If the damper operates properly when the circuit is powered up, disconnect the power, remove the jumper and proceed to the next step.

Make sure power to the Stage 1 boiler circuit is off and install a jumper in the terminal plug between the *Stage 1* (9 and 10) terminals. When the circuit is powered-up, the boiler should operate. If it does not come on, check the circuit wiring for errors and ensure that it is powered up and the voltage is correct. Check the devices in the circuit (limits, flow switches, etc.) for faults. If the boiler operates properly when the circuit is powered up, disconnect the power, remove the jumper and check the remaining stages in the same way. If all stages operate correctly, proceed to the next step.

Connect the control

Turn the power off and make sure all test jumpers have been removed from the plugs.

Connect the plugs to the control by carefully aligning them with their respective headers and pushing them upwards into the headers. The plugs should snap firmly into place.

The control wiring is now complete and has been tested. The control is ready for set-up and operation.

Caution

The tekmar Eight Stage Boiler Control 258 is an operating control and is not certified or intended for use as a safety device. Under no circumstances should safety limit devices be left disconnected after installation of this control. The installer shall check all applicable code requirements and obtain necessary inspections to ensure that the installation is in compliance with those requirements. This Control operates remote devices such as pumps and combustion air dampers as well as the boilers, and these devices may be started by the control at any time. Installers must install approved electrical disconnects at these locations to allow these devices to be serviced safely.

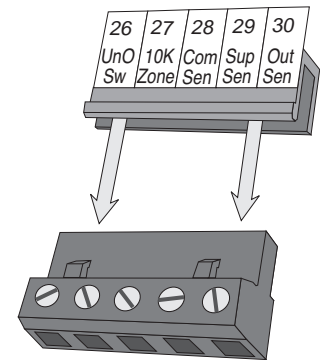

Terminal plug disconnected from its header on the control

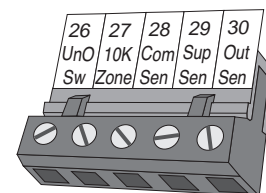

Terminal plug pushed into its header on the control

Settings

Step Six Essential control settings

To obtain the best operation from a reset control, it is important to measure the system supply temperature as accurately as possible. Whenever the control receives a heat demand signal, the system pump must be operated to maintain continuous water flow past the supply temperature sensor.

For specific application details refer to Application Brochure A 258.

A more detailed technical description of the effect of control settings on overall system operation is described in the tekmar Essay, E 002.

Reset operation

Stpnt — Reset switch

When the boilers are used in a heating system and the supply temperature is to be controlled on an outdoor reset schedule (Heating Curve), this switch must be set to "Reset".

Programming the control for Occupied/Unoccupied room temperatures and setback schedules will be covered in the "Programming" section starting on page 15.

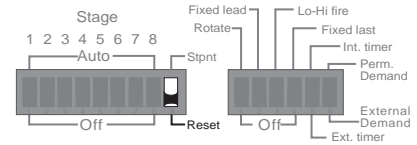

Heat Demand switch

When the heating system uses zone valve end switches or some other means of delivering an external heat demand signal to terminals *Heat Dem* (5 and 6), set this selector switch to "External Demand" and the control will be enabled when it receives a 24Vac signal from the heat demand circuit. If an external heat demand signal is not used, set the switch to "Permanent Demand".

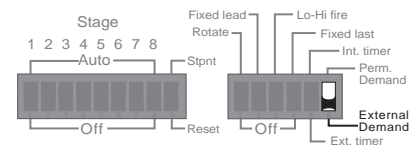

Heating Curve

As outdoor temperatures drop, heat losses from a building become greater and the heating system supply water temperature must be raised to maintain a constant room temperature. The heating curve value describes how many degrees the supply water temperature is raised for a one degree drop in outdoor temperature. The supply temperature starts to increase when the outdoor temperature falls below the WWSD point. To calculate the correct setting for the Heating Curve, use the following formula.

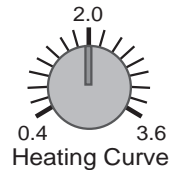

$$\text{Heating Curve} = \frac{\text{design supply temperature} - \text{room temperature}}{\text{room temperature} - \text{design outdoor temperature}}$$

- For example:
- design outdoor temperature = 5°F (-15°C)
 - room temperature = 70°F (21°C)
 - design supply temperature = 160°F (71°C)

$$\text{Heating Curve} = \frac{160^{\circ}\text{F} - 70^{\circ}\text{F}}{70^{\circ}\text{F} - 5^{\circ}\text{F}} = \frac{90^{\circ}\text{F}}{65^{\circ}\text{F}} = 1.4$$

For more information regarding the Heating Curve, refer to page 2 of this brochure. If the actual design supply water temperature for a system is unknown, a trial setting can be calculated using these typical supply temperatures:

- Fan coils ... 180° to 210°F (82° to 99°C)
- Baseboards ... 160° to 190°F (71° to 88°C)
- Radiant floors ... 100° to 130°F (38° to 54°C).

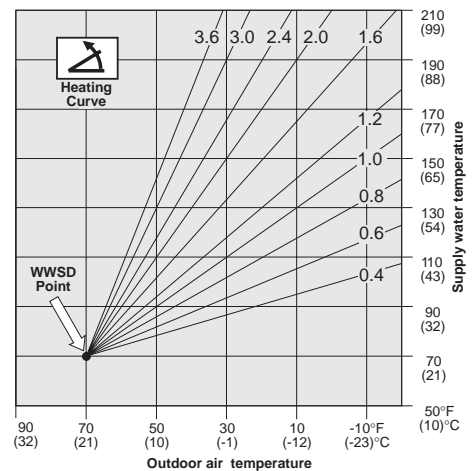

Setpoint operation

Stpnt — Reset switch

When the boilers are used to maintain the supply temperature at a setpoint, set this switch to "Stpnt".

Programming the control for Occupied/Unoccupied setpoint temperatures and setback schedules will be covered in the "Programming" section starting on page 15.

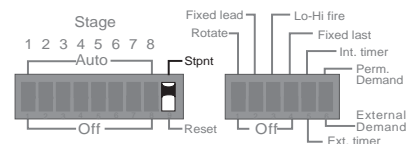

Setpoint Demand switch

End switches, aquastats or some other means of delivering an external setpoint demand signal can be used to bring 24Volts to terminals *Heat Dem* (5 and 6) when the control is used as a setpoint control. This selector switch should be set to "External Demand" and the control will be enabled when it receives the 24Vac signal. If an external setpoint demand signal is not used, set to "Permanent Demand".

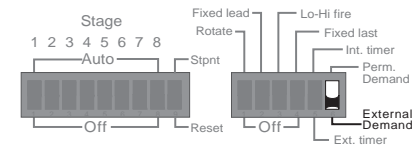

Common Settings

Stage 1, 2, 3, 4, 5, 6, 7, & 8 Auto or Off switch

When a stage switch is set to "Auto", that particular stage becomes active and its boiler is available for operation. If the stage switch is "Off", the control will ignore that stage and not turn it on.

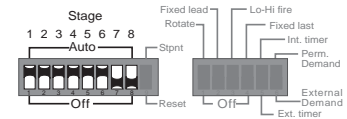

Rotate switch

When this switch is set to "Rotate", the firing order of the stages is changed to even out wear and tear on the boilers. Whenever one stage accumulates 48 hrs more running time than the others, it will be rotated to be the last boiler fired and the boiler with the least amount of running time will become the lead boiler. Whenever the Test button is pushed, the control automatically re-ranks the firing sequence based on accumulated running times. When the Rotate switch is set to "Off", the firing order will always stay the same; 1,2,3,4,5,6,7,8 to stage on, and reverse order to stage off.

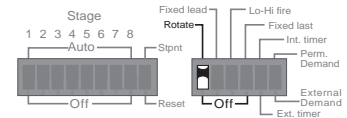

Fixed lead switch

When the boilers are to be rotated and this switch is set to "Fixed lead", the stages are rotated as described above with the exception that Stage 1 will always be the first boiler to fire and the first boiler to stage off. This feature is commonly used when a high efficiency lead boiler is used in conjunction with mid efficiency boilers to increase overall heating plant efficiencies, or when the boiler closest to a chimney needs to be fired first in order to establish draft in the chimney.

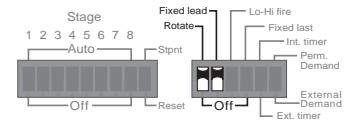

Lo-Hi fire switch

When boilers are to be rotated and Lo-Hi fire boilers are used, the stages must be rotated in such a way as to prevent possible High fire starts and mixing up of the stages between boilers. When this switch is set to "Lo-Hi fire", the stages rotate as Lo-Hi fire pairs (1 & 2 and 3 & 4, etc.) and the hours of use are calculated based on the Lo fire run times. In addition, the control will not allow a Hi fire stage to operate if its corresponding Lo fire stage DIP switch has been turned off. (ie. if Stage 1 is turned off, stage 2 will not be allowed to fire and the control will move on to 3 & 4)

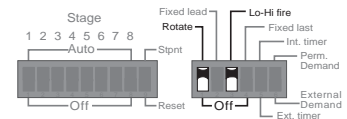

Fixed last switch

When the boilers are to be rotated and this switch is set to "Fixed last", the stages are rotated as described above with the exception that Stage 8 will always be the last boiler to fire and the first boiler to stage off. This feature is commonly used to operate a diverting valve which will allow Domestic Hot Water boilers to be switched over to assist the heating boilers during peak load times.

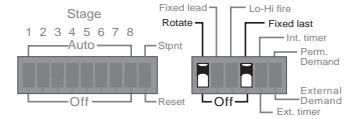

Int. timer switch

The 258 control has an internal timer – programmed using the LCD display and keypad – that can be used to switch up to two Occupied/Unoccupied events per day on a 7 day basis.

Details on the operation of this timer can be found in the "Programming" section on page 15.

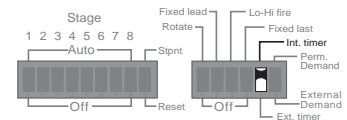

Ext. timer switch

The 258 control can be switched into the Unoccupied mode by an external signal when a dry contact closure occurs between terminals *UnO Sw — Com Sen* (26 & 28).

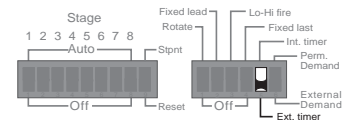

Minimum Supply Temperature

This dial should be set according to the requirements specified by the boiler manufacturer. Many boilers require a minimum operating temperature to prevent corrosion from flue gas condensation. The control raises the supply temperature to the Minimum setting when the outdoor temperature drops below the WWSD point, and holds it there until the outdoor temperature becomes cold enough to require operation on the heating curve.

*Note: Many boiler manufacturers requires a minimum **return** temperature to their equipment. In systems where this is a strict requirement, the minimum supply temperature setting should be set to the recommended return temperature **plus the boiler ΔT under full load conditions.***

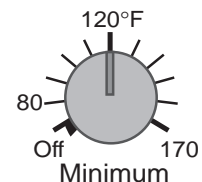

Overheating of buildings in warm weather will occur where minimum boiler temperatures are required, unless the building has either a mixing system to reduce system supply water temperatures to below boiler minimums, or some sort of room temperature control and zoning system. Zone controls from tekmar, when used in these applications, will provide room temperature feedback information to this control, allowing it to shift the heating curve for maximum comfort and energy savings.

Typical Minimum Boiler Operating Temperatures: • Steel Tube Boilers ... 140° to 180°F (60° to 82°C) • Cast Iron Boilers ... 130° to 150°F (54° to 66°C) • Copper Tube Boilers ... 105° to 150°F (41° to 66°C) • Condensing or Electric Boilers ... Off

Note: If the control is being operated in the setpoint mode and a boiler minimum setting is selected, the user will be unable to program a setpoint lower than the minimum temperature plus 1/2 of the Boiler Differential setting. If the minimum dial is set higher than the setpoint less 1/2 the Boiler Differential, the setpoint will automatically be raised as the dial is turned up. If the dial is then turned back down, the setpoint will have to be re-programmed.

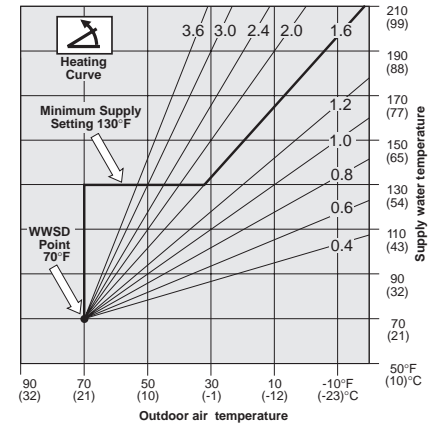

Boiler Differential and Time Delay

The Boiler Differential adjustment sets how much the actual supply water temperature may deviate from the desired temperature before stages are turned on or off, and is determined by the flow rate past the supply sensor relative to the amount of heat produced by each stage. To prevent short operating cycles of the boilers the control has a delay of at least 1 minute between firing cycles. On an installation where flow rates are known, the Boiler Differential can be calculated as follows:

$$\text{Boiler Differential} = \frac{\text{Btu/hr}}{\text{US GPM} \times 500}$$

For example: $\frac{100,000 \text{ Btu/hr}}{20 \text{ US GPM} \times 500} = 10^\circ\text{F} (6^\circ\text{C})$

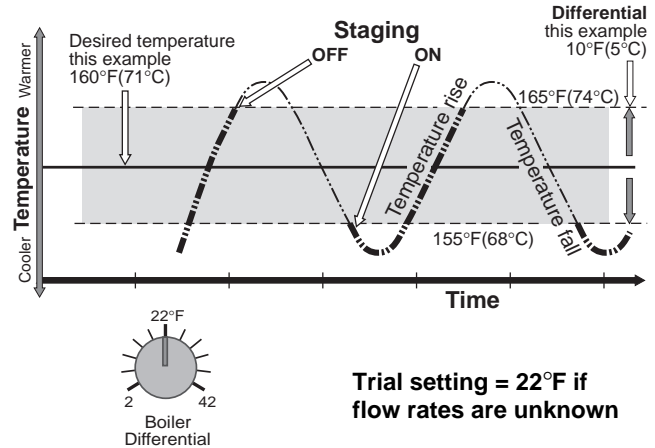

All boilers will eventually turn on when the temperature falls and stays 5°F (3°C) below the desired temperature. Delays of 1 to 5 minutes for staging on depend on the degree of control error (P+I+D). As the temperature rises to within the differential range, no boilers are staged on or off. All boilers will eventually turn off when the temperature rises and stays 5°F (3°C) above the desired temperature. Delays of 8 seconds to 3 minutes for staging off depend on the degree of control error.

Setting a boiler differential for modular boilers is often complicated by the fact that flow rates and heating loads may vary widely, and at times boiler outputs may not be balanced to the load. Observing the "Target Supply" fixed display while the boilers are staging can assist the user in understanding system flow and boiler problems. The ideal control reaction occurs when the target supply temperature remains constant or only changes slightly during the staging process, indicating a well balanced and constant – or slowly changing – load vs. output in the system.

If the target supply temperature decreases rapidly when a boiler comes on, it indicates a heavy derivative action by the control in response to a rapid supply temperature increase. This type of action typically indicates a condition where the boiler output is far in excess of the load, a situation that is usually the result of a system that is operating with only a few zones open (decreased load). Setting a wider differential and ensuring a minimum fixed load (wild loops) can help minimize this problem.

If the target supply temperature increases rapidly, it indicates a heavy derivative action by the control in response to a rapid load increase. This type of action typically indicates situations where the load is not finely divided (a few large zones) and is usually the result of one large zone opening – or a system coming out of setback – and delivering cold water to the boilers (increased load). Typically, this will cause many or all of the boilers to be staged on with minimum delay, which is the correct control action for the situation.

If the load fluctuates rapidly and repeatedly from heavy to light, some instability may result in the staging process as the control tries to bring on many boilers at once and then shut them off again when the load suddenly decreases. The target temperature will be constantly increasing and decreasing. Setting a wider differential will help to stabilize the control action in many of these cases.

If the target supply temperature slowly and continually climbs, it indicates that the supply temperature is not rising to the target temperature. The control will continue to request more and more boilers until the supply temperature rises sufficiently to reduce the control error. This problem is called "Reset Windup" and can occur in systems where: (a) the boilers are undersized, (b) flow is interrupted – without removing the heat demand – to the point where the supply sensor cannot detect the supply temperature increase, or (c) where the supply sensor is incorrectly placed – ie. on the wrong pipe or on the return of a system with very long runs. The problem must be identified and corrective action taken.

If the target supply temperature slowly and continually decreases after the boilers have been shut down, it indicates that the supply temperature is hotter than the target temperature. This can happen in systems with high mass boilers where the flow has been stopped without using the heat demand input to the control, and convection from the still hot boiler continues to heat the supply sensor. If the heat demand input is used to shut the system down, the control will ignore the sensor reading during the off cycle.

Test button

The control can be made to cycle through a test routine whenever the Test button is pushed. The test can be halted at certain times by pushing the button a second time. For details of the test routine, refer to the description starting on the next page.



Testing the Control Functions

Step Seven

Operational test of control functions - Test button

The Eight Stage Boiler Control 258 has a Test button which can be used to test the main control functions any time there is a "fixed display" showing. When the Test button is pushed, the control automatically runs through this test procedure. If a fault is detected, the display shows an Error Message. These Error Messages are listed on page 14.

Full Display and red temperature indicator lights on

At the start of each test routine and on power-up, the full display and all of the red temperature indicator lights are switched on for approximately 5 seconds. During this time the control searches for sensor faults and, if no faults are found, proceeds to the next step. If a sensor fault exists, the control exits the test routine and the display will show an Error Message. See page 14.

Power, Test, Comb. air light on - Display = "C A"

The control signals the combustion air damper to open (whether there is one connected or not) and will wait for 10 seconds before:

(a) — proceeding to the next step, OR (b) — During the 10 seconds, if there is a Heat Demand or Setpoint Demand signal and the Test button is pressed, the test routine will be halted, the "Test" light will flash, and the control will be held in a pause mode for up to 5 minutes. During this time, the combustion air damper will remain open. After the 5 minutes, the control will automatically exit the test routine and enter the normal operating mode. If there is no Heat Demand, the control will not allow a pause and will proceed to the next step of the test routine. Pushing the Test button during the 5 minute pause will allow the control to proceed to the next step of the test routine immediately. The open signal (and "Comb. air" light) remains on for the duration of the test routine.

Power, Test, Comb. air, Pump light on - Display = "P"

The control turns on the system pump for 10 seconds and:

(a) — proceeds to the next step, OR (b) — During the 10 seconds, if there is a Heat Demand or Setpoint Demand signal and the Test button is pressed, the test routine will be halted, the "Test" light will flash, and the control will be held in a pause mode for up to 5 minutes. During the 5 minutes, the System pump will remain on. After the 5 minutes, the control will automatically exit the test routine and enter the normal operating mode. If there is no Heat Demand, the control will not allow a pause and will proceed to the next step of the test routine. Pushing the Test button during the 5 minute pause will allow the control to proceed to the next step of the test routine immediately.

Power, Test, Comb. air, Pump, Stage 1 light on - Display = "b 1"

If there is a Heat or Setpoint Demand, the system pump will remain on. The control will turn on stage 1 for 10 seconds and:

(a) — proceed to the next step, OR (b) — During the 10 seconds, if there is a Heat or Setpoint Demand signal, and the Test button is pressed, the test routine will be halted, the "Test" light will flash, and the control will be held in a pause mode for up to 5 minutes. Push the Test button during the 5 minute pause and the control will proceed to the next step immediately. During the 5 minutes, the Pump and Stage 1 will remain on. After the 5 minutes, the control will automatically exit the test routine and enter the normal operating mode. If there is no Heat or Setpoint Demand, the Pump will not be running, the control will not allow a pause and will proceed to the next step of the test routine. The control will repeat this step for each of the stages that are switched to "Auto" at the DIP switches, and after the last stage is tested will exit the test routine and enter normal operating mode.

Note:

Whenever the control exits the test routine, there is a 4 second delay before the control can be made to re-enter the test routine. Pushing the Test button during this 4 second period will have no effect on the control.

Power light on — Test light off

The control has exited the test routine, entered the operating mode and will function according to the sequence of operation described on pages 4 – 6. One or more of the other indicator lights may also be on. Refer to pages 4 - 6 for a description of the indicator lights under operating conditions.

TEST ROUTINE – AUTO/MANUAL

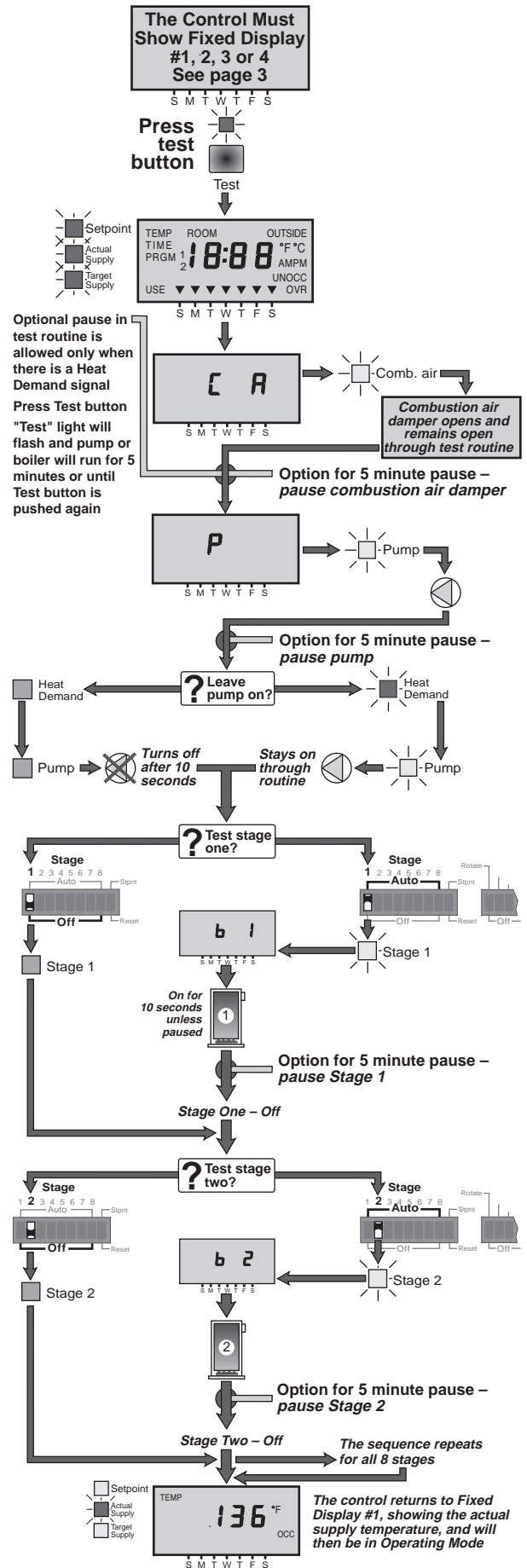

Error Messages

Step Eight — Troubleshooting

As in any troubleshooting procedure, it is important to isolate a problem as much as possible before proceeding. The 258 can help the user in three significant ways.

- (1) — The Error Messages can pinpoint certain problems and eliminate others.
- (2) — Cycling the control through the test routine allows the operation of the various components to be examined individually and in a systematic way to greatly simplify troubleshooting.
- (3) — The display can show outdoor, actual supply and target supply temperatures, and the LED system status lights display the operation of the various system components. A competent troubleshooter can locate system faults without having to go any further than observation of these important temperature and status indicators.

If a fault occurs during operating mode or during the test routine and the control is flashing an Error Message, identify the fault from the look-up table on the right side of this page and then follow standard testing procedures to confirm the problem.

If you suspect a wiring fault, return to steps four and five and carefully check all external wiring and wiring connections.

Notes:

If the Outdoor Sensor develops either a short circuit or an open circuit, the control is programmed to calculate the outdoor temperature at -8°F (-22°C) and control the supply temperature accordingly.

The control is programmed to shut the boilers down before the supply temperature can reach a maximum allowable supply water temperature of 248°F (120°C).

If the Supply Sensor develops either a short circuit or an open circuit, the control is programmed to shut down the boilers and run the system pump to prevent overheating.

If a Zone Control input becomes shorted out, the Occupied or Unoccupied setting will become active.

After any repair has been completed, press the Test button to allow the control to cycle through the test routine. This will allow you to confirm that correct operation has been restored and that wiring connections are undisturbed.

Step Nine — Before you leave

Make sure wiring dividers are installed in the proper locations between compartments having different voltages.

Install the wiring cover over the wiring chamber and secure it to the base with the two screws provided. Place the front cover on the control to cover the setting dials and snap it into place. Install a lock if security is required.

Place this brochure, and all other brochures relating to the installation, in the protective plastic bag supplied with the control. Place the bag in a conspicuous location near the control for future reference, as programming instructions will need to be accessible for future users.

It is important to explain the operation and maintainance of this control and of the system to the end user and anyone else who may be operating the system.

If a sensor fault occurs during normal operation or during the test routine, the word "Err" will appear in the display screen and the display will flash back and forth between "Err" and one of the error codes listed below.

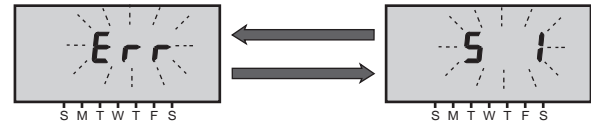

OUTDOOR SENSOR — SHORT CIRCUIT

- ▶ The display flashes between "Err" and "S 1"
- ▶ Check the outdoor sensor and the wiring from the terminal plug to the sensor.
- ▶ With this error, the control will operate the boilers as if the outdoor temperature was -8°F (-22°C)

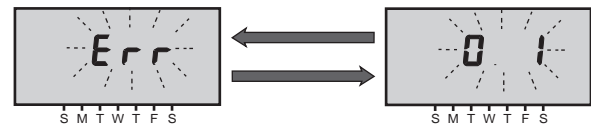

OUTDOOR SENSOR — OPEN CIRCUIT

- ▶ The display flashes between "Err" and "O 1"
- ▶ Check the outdoor sensor and the wiring from the terminal plug to the sensor.
- ▶ With this error, the control will operate the boilers as if the outdoor temperature was -8°F (-22°C)

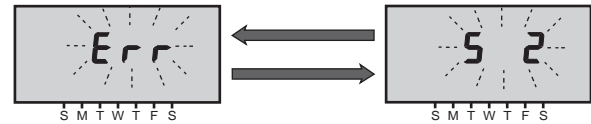

SUPPLY SENSOR — SHORT CIRCUIT

- ▶ The display flashes between "Err" and "S 2"
- ▶ Check the supply sensor and the wiring from the terminal plug to the sensor.
- ▶ With this error, the control will shut down the boilers, close the combustion air damper but leave the pump on.

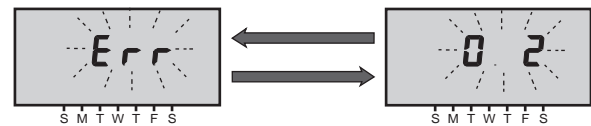

SUPPLY SENSOR — OPEN CIRCUIT

- ▶ The display flashes between "Err" and "O 2"
- ▶ Check the supply sensor and the wiring from the terminal plug to the sensor.
- ▶ With this error, the control will shut down the boilers, close the combustion air damper but leave the pump on.

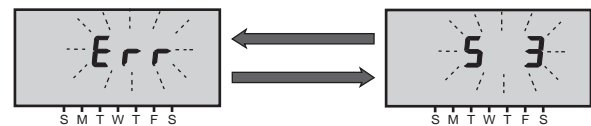

ZONE CONTROL — SHORT CIRCUIT

- ▶ The display flashes between "Err" and "S 3"
- ▶ Check the wiring from the terminal plug to the 10K Zone Control.
- ▶ With this error, the control loses its indoor temperature feedback and operates at the Occ or Unocc settings.

TIME/DAY MENU – PROGRAMMING

PROGRAM MENU – VIEWING

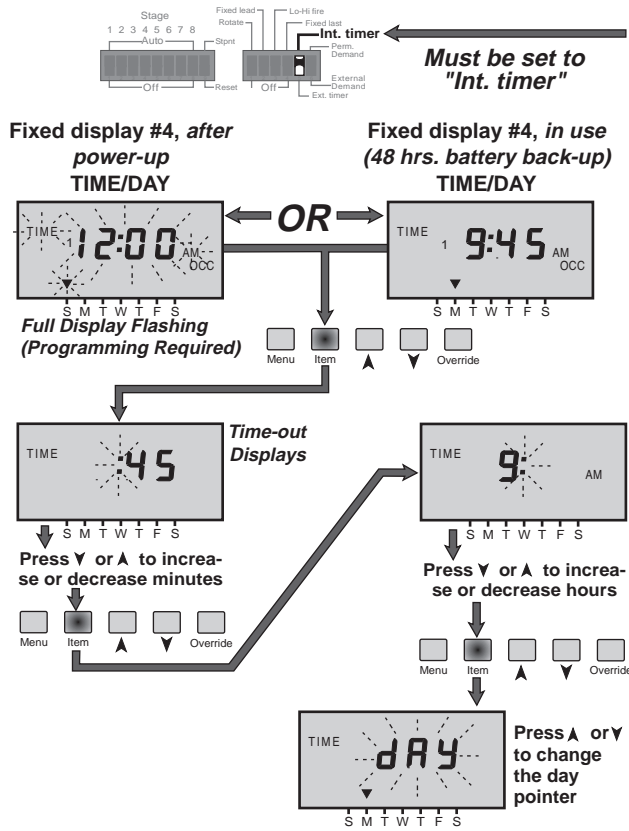

Note: These program displays are "Time-out" displays

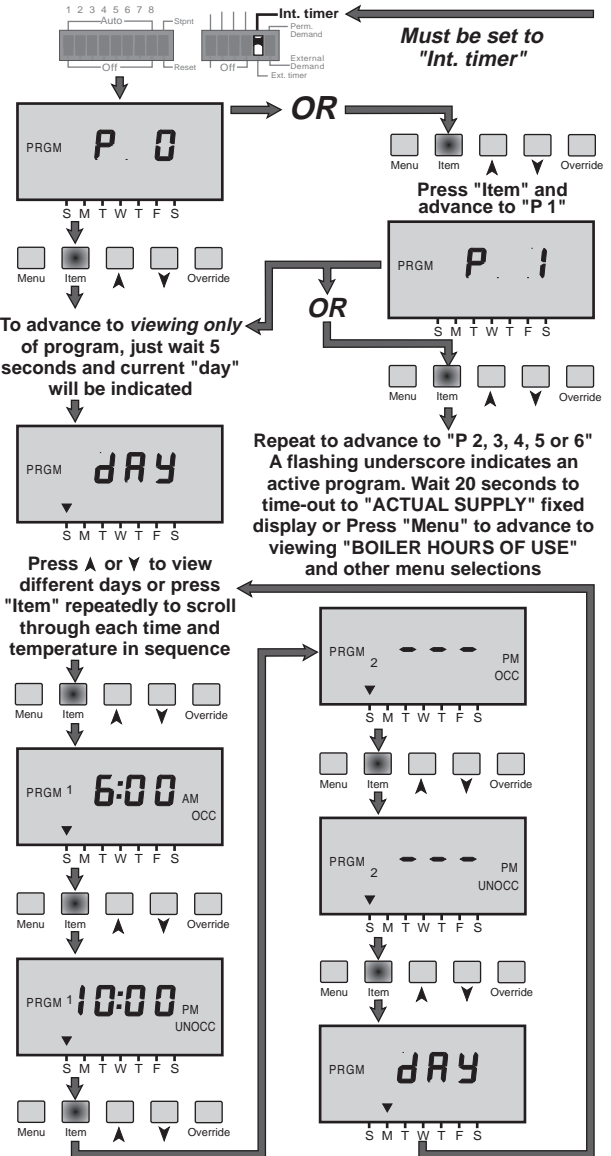

PROGRAMMING

BOILER HOURS OF USE MENU – VIEWING

PROGRAM MENU – "P 1 TO P 6 PROGRAMMING

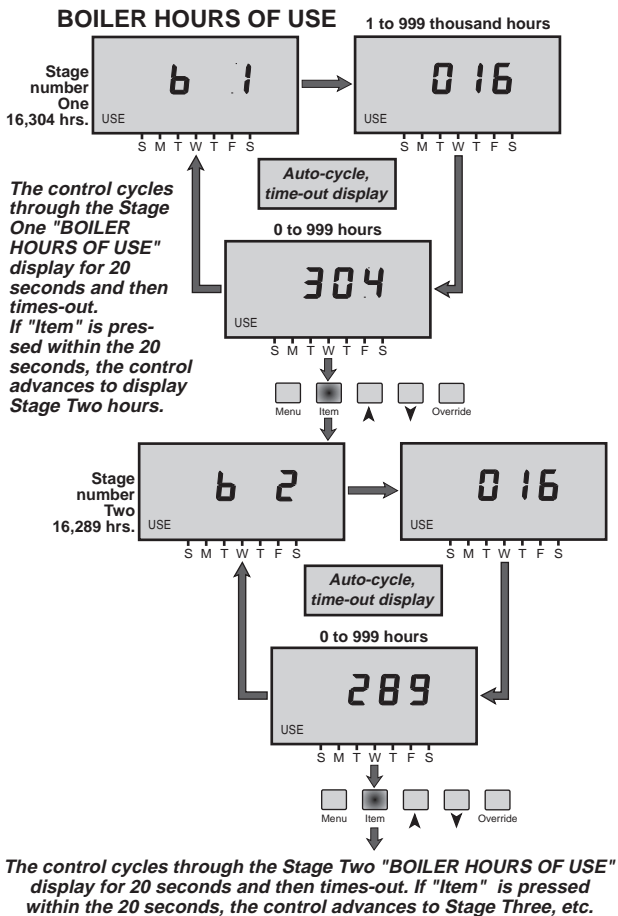

To Select a Program:

Choose the program you would like to enter (page 18)
Advance to "PROGRAM MENU" and press "Item" repeatedly until that program indicator is displayed

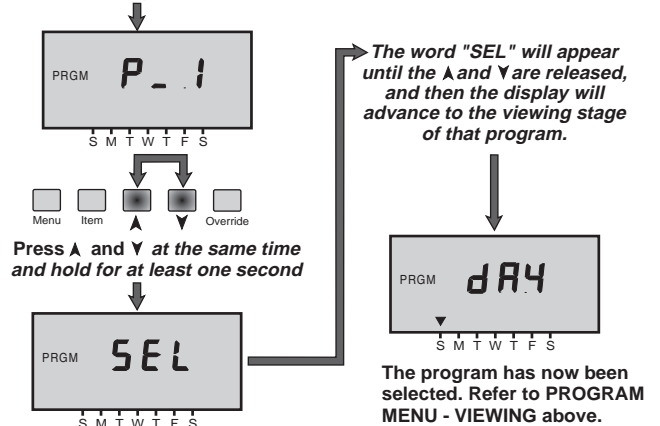

PROGRAM MENU – "P 0" PROGRAMMING

Note: All "PROGRAM" displays are "Time-out" displays



Advance through the Menu to the "PROGRAM" display



Only "P 0" can be programmed by the user. Pre-programmed schedules are located by pressing "Item" to display "P 1 to P 6". Refer to "PROGRAM MENU – VIEWING" pg 16



To program schedule "P 0", press **▲** and **▼** at the same time and hold for one second



The word "SEL" will appear briefly, "P 0" is selected



When "day" is flashing press **▲** or **▼** to select desired day of week



When "1" and "OCC" are flashing press **▲** or **▼** to select occupied #1 time



When "1" and "UNOCC" are flashing press **▲** or **▼** to select unoccupied #1 time



When "2" and "OCC" are flashing press **▲** or **▼** to select occupied #2 time



Options

Program "P 0" can be cleared for re-programming

Press "Item", **▼** and **▲** At the same time and hold for one second

A schedule event can be skipped by programming a "Null Event"

To program a Null Event, Set the time for that event to between 11:50 PM and 12:00 AM by pressing **▼** or **▲**

Every day can be programmed to have the same schedule

Press **▼** or **▲** until all of the days indicators appear. Program once for all days

Wait 20 seconds to time-out to "ACTUAL SUPPLY" fixed display or Press "Menu" to advance to viewing "BOILER HOURS OF USE" and other menu selections. When "P 0" is selected, the "P 0" underscore indicator will be flashing



When "2" and "UNOCC" are flashing press **▼** or **▲** to select unoccupied #2 time



The control will automatically cycle to access programming for the next day

OCCUPIED/UNOCCUPIED OVERRIDE



Fixed display 1, 2, 3 or 4 must be showing (See page 3)



"OCC" will be flashing. Allow control to time-out or press "Menu", and control will be in Occupied override. The normal program will resume at the start of the next Occupied event

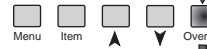

Or – push "Override" again and:

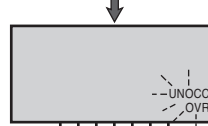

"UNOCC" will be flashing. Allow control to time-out or press "Menu", and control will be in Unoccupied override. The normal program will resume at the start of the next Unoccupied event



Or – push "Override" again and:

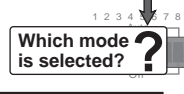

Press **▲** or **▼** to program permanent override temperature, allow control to time-out or press "Menu", and the control operates at the override temperature regardless of schedule programming until override button is pressed again



Or push "Override" again and: **Override function is shut off.** The control times-out to starting fixed display

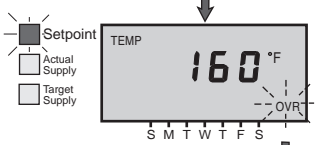

Note: After selecting an override function, the user can avoid waiting for the time-out by pressing the "Menu" button. The control will return to the starting fixed display

Override indicators (Control must be showing a fixed display)

"OCC" indicator on and "OVR" indicator slowly flashing. The control is in temporary occupied override. Regular program will resume at the start of the next occupied event

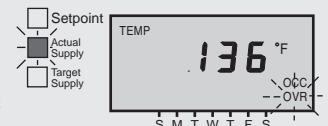

"UNOCC" indicator on and "OVR" indicator slowly flashing. The control is in temporary unoccupied override. Regular program will resume at the start of the next Unoccupied event

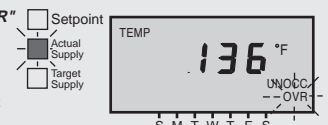

"OVR" indicator on steady. The control is in permanent override and the temperature will be controlled at the permanent override setting

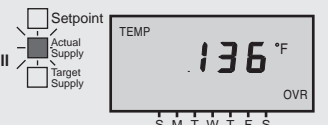

To cancel an override option that has been selected, press the "Override" button when the control is showing a fixed display

PRE-PROGRAMMED SCHEDULES

Schedule "P 1"

Day	Time	Temperature
Sunday	8:00 am	Occ 1
	10:30 pm	UnOcc 1
	Null	Occ 2
	Null	UnOcc 2
Monday	6:00 am	Occ 1
	10:30 pm	UnOcc 1
	Null	Occ 2
	Null	UnOcc 2
Tuesday	6:00 am	Occ 1
	10:30 pm	UnOcc 1
	Null	Occ 2
	Null	UnOcc 2
Wednesday	6:00 am	Occ 1
	10:30 pm	UnOcc 1
	Null	Occ 2
	Null	UnOcc 2
Thursday	6:00 am	Occ 1
	10:30 pm	UnOcc 1
	Null	Occ 2
	Null	UnOcc 2
Friday	6:00 am	Occ 1
	10:30 pm	UnOcc 1
	Null	Occ 2
	Null	UnOcc 2
Saturday	8:00 am	Occ 1
	11:30 pm	UnOcc 1
	Null	Occ 2
	Null	UnOcc 2

Schedule "P 2"

Day	Time	Temperature
Sunday	9:00 am	Occ 1
	9:30 pm	UnOcc 1
	Null	Occ 2
	Null	UnOcc 2
Monday	7:00 am	Occ 1
	9:30 pm	UnOcc 1
	Null	Occ 2
	Null	UnOcc 2
Tuesday	7:00 am	Occ 1
	9:30 pm	UnOcc 1
	Null	Occ 2
	Null	UnOcc 2
Wednesday	7:00 am	Occ 1
	9:30 pm	UnOcc 1
	Null	Occ 2
	Null	UnOcc 2
Thursday	7:00 am	Occ 1
	9:30 pm	UnOcc 1
	Null	Occ 2
	Null	UnOcc 2
Friday	7:00 am	Occ 1
	10:30 pm	UnOcc 1
	Null	Occ 2
	Null	UnOcc 2
Saturday	9:00 am	Occ 1
	10:30 pm	UnOcc 1
	Null	Occ 2
	Null	UnOcc 2

Schedule "P 3"

Day	Time	Temperature
Sunday	8:00 am	Occ 1
	10:30 pm	UnOcc 1
	Null	Occ 2
	Null	UnOcc 2
Monday	6:00 am	Occ 1
	8:30 am	UnOcc 1
	5:00 pm	Occ 2
	10:30 pm	UnOcc 2
Tuesday	6:00 am	Occ 1
	8:30 am	UnOcc 1
	5:00 pm	Occ 2
	10:30 pm	UnOcc 2
Wednesday	6:00 am	Occ 1
	8:30 am	UnOcc 1
	5:00 pm	Occ 2
	10:30 pm	UnOcc 2
Thursday	6:00 am	Occ 1
	8:30 am	UnOcc 1
	5:00 pm	Occ 2
	10:30 pm	UnOcc 2
Friday	6:00 am	Occ 1
	8:30 am	UnOcc 1
	5:00 pm	Occ 2
	11:30 pm	UnOcc 2
Saturday	8:00 am	Occ 1
	11:30 pm	UnOcc 1
	Null	Occ 2
	Null	UnOcc 2

Schedule "P 4"

Day	Time	Temperature
Sunday	Null	Occ 1
	Null	UnOcc 1
	Null	Occ 2
	Null	UnOcc 2
Monday	7:00 am	Occ 1
	5:30 pm	UnOcc 1
	Null	Occ 2
	Null	UnOcc 2
Tuesday	7:00 am	Occ 1
	5:30 pm	UnOcc 1
	Null	Occ 2
	Null	UnOcc 2
Wednesday	7:00 am	Occ 1
	5:30 pm	UnOcc 1
	Null	Occ 2
	Null	UnOcc 2
Thursday	7:00 am	Occ 1
	5:30 pm	UnOcc 1
	Null	Occ 2
	Null	UnOcc 2
Friday	7:00 am	Occ 1
	5:30 pm	UnOcc 1
	Null	Occ 2
	Null	UnOcc 2
Saturday	Null	Occ 1
	Null	UnOcc 1
	Null	Occ 2
	Null	UnOcc 2

Schedule "P 5"

Day	Time	Temperature
Sunday	Null	Occ 1
	Null	UnOcc 1
	Null	Occ 2
	Null	UnOcc 2
Monday	7:00 am	Occ 1
	5:30 pm	UnOcc 1
	Null	Occ 2
	Null	UnOcc 2
Tuesday	7:00 am	Occ 1
	5:30 pm	UnOcc 1
	Null	Occ 2
	Null	UnOcc 2
Wednesday	7:00 am	Occ 1
	5:30 pm	UnOcc 1
	Null	Occ 2
	Null	UnOcc 2
Thursday	7:00 am	Occ 1
	5:30 pm	UnOcc 1
	Null	Occ 2
	Null	UnOcc 2
Friday	7:00 am	Occ 1
	5:30 pm	UnOcc 1
	Null	Occ 2
	Null	UnOcc 2
Saturday	7:00 am	Occ 1
	5:30 pm	UnOcc 1
	Null	Occ 2
	Null	UnOcc 2

Schedule "P 6"

Day	Time	Temperature
Sunday	Null	Occ 1
	Null	UnOcc 1
	Null	Occ 2
	Null	UnOcc 2
Monday	1:00 am	Occ 1
	Null	UnOcc 1
	Null	Occ 2
	Null	UnOcc 2
Tuesday	Null	Occ 1
	Null	UnOcc 1
	Null	Occ 2
	Null	UnOcc 2
Wednesday	Null	Occ 1
	Null	UnOcc 1
	Null	Occ 2
	Null	UnOcc 2
Thursday	Null	Occ 1
	Null	UnOcc 1
	Null	Occ 2
	Null	UnOcc 2
Friday	Null	Occ 1
	2:30 pm	UnOcc 1
	Null	Occ 2
	Null	UnOcc 2
Saturday	Null	Occ 1
	Null	UnOcc 1
	Null	Occ 2
	Null	UnOcc 2

Technical Data

Technical Specifications

Dimension (h x w x d)	— 6-5/8" x 7-9/16" x 2-13/16" (170 x 193 x 72mm)
Weight	— 2.9 lbs (1.3 Kg)
Ambient	— 30 to 120°F (0 to 50°C), < 95% RH non-condensing
Power supply	— 24Vac ± 10%, 60Hz, 5VA class II — For alternate power supplies (50Hz or 24Vdc), contact the factory
Relay capacity	— 9 x SPST, 24Vac, 10 Amps – 1 x SPDT, 24Vac, 8 Amps
Sensors	— Outdoor Sensor 070, Sensor 071; Accurate with up to 500 feet (150m) 18AWG cable
Control accuracy (temp.)	— ± 1°F (± 0.5°C)
Control Processing	— PID algorithm

This electronic control does not exceed the Class B limits for radio noise emissions from digital apparatus as set out in the Radio Interference Regulations of the Canadian Department of Communications. Le présent numérique n'émette pas de bruits radioélectriques dépassant les limites applicables aux appareils numériques de Classe B prescrites dans le règlement sur le brouillage radioélectrique édicté par le Ministère des Communications du Canada.

Features

18 Indicator lights	— Power, Heat Demand, Setpoint, WWSD, Minimum, Comb. air, Pump, Actual Supply, Target Supply Stage 1, Stage 2, Stage 3, Stage 4, Stage 5, Stage 6, Stage 7, Stage 8, Test
Comb. air damper output	— Isolated SPST relay contacts close before first boiler is fired (60 sec.)
Pump output	— Isolated SPST relay contacts close when heating or setpoint is required
Stage 1 to 7 output	— Isolated SPST relay contacts close to operate each stage
Stage 8	— Isolated SPDT relay contacts. N.O. contacts close to operate Stage 8
Test button	— Initiates and controls pre-programmed test run
Error message display	— Sensor faults are indicated by flashing light code
Setback timer/clock	— Programmable
Memory backup	— Retains programmed information and boiler run times when powered down for up to 10 years
Battery backup	— Maintains clock operation for 24hrs when powered down

Dial & Switch Settings

Heating Curve	— 0.4 to 3.6
Minimum	— Off, 80 to 170°F (Off, 27 to 77°C)
Boiler Differential	— 2 to 42°F (1 to 23°C)
Stage 1 to 8 switches	— To switch each Stage off or into operating mode
Rotate switch	— To allow boilers to rotate firing sequence based on hours of use (re-ranks after 48 hrs of use)
Fixed lead switch	— Configures Stage 1 to be first/on first/off regardless of hours of use
Fixed last switch	— Configures last Stage to be last on first off regardless of hours of use
Lo/Hi fire switch	— Configures Stages to fire and rotate as pairs
Timer switch	— Setback input from internal timer or external source
Heat Demand switch	— External 24Vac signal or permanent internal signal
Setpoint/Reset switch	— Control operates in reset or setpoint mode

Keypad Programming

Occupied room temperature	— 35 to 105°F (2 to 41°C)
UnOccupied room temperature	— 35 to 105°F (2 to 41°C)
Occupied Setpoint temperature	— 70 to 248°F (21 to 120°C)
UnOccupied Setpoint temperature	— 70 to 248°F (21 to 120°C)
Override temperature	— Setpoint or Room temperature ranges depending on mode
Setback schedules	— 6 pre-programmed, 1 programmable — 7 day, 2 events per day

Display Readouts

Desired Occ. temperature	— 35 to 105°F (2 to 41°C)
Desired UnOcc. temperature	— 35 to 105°F (2 to 41°C)
Desired Occ. Setpoint temp.	— 70 to 248°F (21 to 120°C)
Desired UnOcc. Setpoint temp.	— 70 to 248°F (21 to 120°C)
Override temperature	— Setpoint or Room temperature ranges depending on mode
Actual Supply temperature	— -67 to 293°F (-55 to 145°C)
Outdoor temperature	— -67 to 293°F (-55 to 145°C)
Target supply temperature	— 35 to 248°F (2 to 120°C)
Boiler accumulated running times	— 0 to 999,999 hrs. for each stage
Setback schedules	— 6 pre-programmed, 1 programmable — 7 day, 2 events per day
Time of Day/Day of Week	— 12 hr., 7 day clock



THE BOILER CONTROL SPECIALIST

The Right Control For Your Application



One Stage Boiler Control 250



One Stage Boiler & DHW Control 251



Two Stage Boiler & DHW Control 252



Four Stage Boiler Control 254



Eight Stage Boiler Control 258

And more to come!

Contact your wholesaler or tekmar agent for information on the newest additions to the tekmar product line.

Sign up for a tekmar Control Course or School and stay up-to-date with our latest control developments.

Limited Warranty and Product Return Procedure

Limited Warranty: tekmar warrants to the original purchaser each tekmar product against defects in workmanship and materials when the product is installed and used in compliance with tekmar's instructions. This limited warranty covers the cost of parts and labour provided by tekmar to correct defects in materials and/or workmanship. Returned products that are fully operational are not considered a warranty case. tekmar also does not cover parts or labour to remove, transport or reinstall a defective product. tekmar will not be liable for any damage other than repair or replacement of the defective part or parts and such repair or replacement shall be deemed to be the sole remedy from tekmar. This warranty shall not apply to any defects caused or repairs required as a result of unreasonable or negligent use, neglect, accident, improper installation, or unauthorised repair or alterations. In case of defect, malfunction or failure to conform to warranty, tekmar will, for a warranty period of 24 months from the date of invoice to the original purchaser or 12 months from the date of installation of the product, whichever occurs first, repair, exchange or give credit for the defective product. Any express or implied warranty which the purchaser may have, including merchantability and fitness for a particular purpose, shall not extend beyond 24 months from the date of invoice or 12 months from the date of installation of the product, whichever occurs first.

Replacements: tekmar can send replacement products if requested. All replacements are invoiced. Any possible credit for the replacement will only be issued once the replaced product has been returned to tekmar.

Product Return Procedure: Products that are believed to have failed must be returned to tekmar Control Systems Ltd. 4611-23rd Street, Vernon B.C. Canada V1T 4K7 when agreed to by tekmar. The installer or other qualified service person must, at the owner's expense, determine which component has failed. The product must be returned complete with all of its components (sensors, base, etc.).

Products must be returned together with the proof of purchase to the original purchaser who then returns the product to tekmar after receiving a Return Goods Authorisation (RGA) number from tekmar.

Please include the following information with the product: The full address of the original purchaser, the RGA number and a description of the problem.

From the U.S.A., in order to avoid customs charges, products must be returned via US Post with the package clearly marked with the RGA number, product type and the statement "Canadian Product returned for repair". For shipping purposes the product can be valued at one half list price.

- 1) If returned during the warranty period and the product is defective, tekmar will issue full credit for the returned product less cost of missing parts.
- 2) If returned during the warranty period and the product is fully operational, tekmar will return the product to the original purchaser for a testing cost of \$30.00 plus postage.
- 3) If returned during the warranty period and the product is not damaged and is fully operational, tekmar can take back the product for a return charge of 40% of the product's net value. This request has to be specified otherwise the product will be returned with a testing cost of \$30.00 plus postage.
- 4) If returned after the warranty period and the product needs repair, tekmar will repair and return the product. Repair and postage costs will be invoiced. tekmar's repair costs are calculated at \$30.00 / hour plus the cost of parts. If the repair costs will be more than \$60.00 a repair estimate will be sent to the original purchaser.

In North America:	tekmar Control Systems Ltd., Canada tekmar Control Systems, Inc., USA Head office: 4611 - 23rd Street Vernon, B.C. Canada V1T 4K7 Tel. (604) 545-7749 Fax. (604) 545-0650
--------------------------	---

