

The tekmar<sup>®</sup> Constant Temperature Control measures and digitally displays the present temperature of an object, and the control allows a user to set a temperature which he desires the object to be maintained at. The control will turn on or off its relay depending on whether the actual temperature is lower or higher than the desired temperature. The temperature of the object may drift  $\pm 0.4^{\circ}\text{F}$  ( $\pm 0.2^{\circ}\text{C}$ ) before the relay is switched. The temperature range of the control is  $-15^{\circ}\text{F}$  ( $-25^{\circ}\text{C}$ ) to  $185^{\circ}\text{F}$  ( $85^{\circ}\text{C}$ ) over which the digital display has an accuracy is  $\pm 0.2^{\circ}\text{F}$  ( $\pm 0.1^{\circ}\text{C}$ ). Outside of this range the accuracy of the digital display cannot be guaranteed. The control has normally open and normally closed relay contacts available at the terminal strip. Whenever the temperature of the measured object is lower than the setpoint, then the pair L' - R1 are closed and the pair L' - R2 are open. A jumper from L to L' provide 24 Vac as the output, otherwise the relay contacts are isolated.



### type 212 includes:

1. Electronic control
2. Control socket
3. Sensor

## Installation

### Mechanical:

The control's socket can be mounted on a DIN rail system or screwed to a flat surface.

### Electrical:

The tekmar control terminates the wires in a plug-in socket; no wires are directly connected to the control. This plug-in system simplifies installation and troubleshooting procedures. Terminals N & L (2 & 3) of the socket must be connected to the secondary side of a 24 Vac class 2 transformer. The total load of the control is approximately 2 VA.

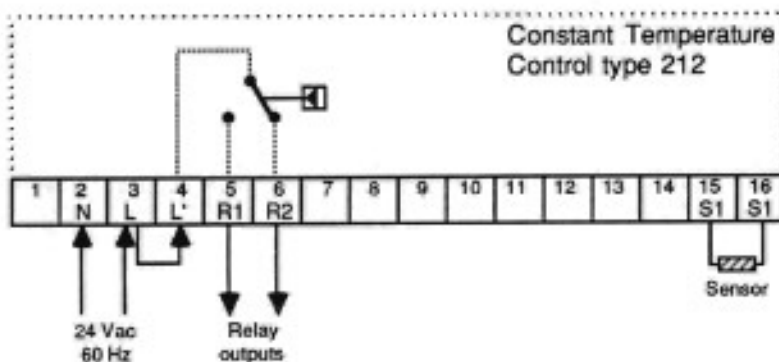

### Technical Data

Ambient Operating Conditions	30 - 120°F (0 - 50°C)
Power Supply	<95% RH Non-condensing 24 Vac $\pm$ 10%, 60 Hz, 2 VA, Class 2 Transformer
Relay Capacity	240 Vac 10 A Ohmic SPDT
Weight	0.7 lbs (0.3 kg)

### Installation of the Sensor:

Note: The sensor is connected to the socket using a 2-conductor cable (eg. 2 x 18 AWG). The overall length of the cable can be 1700 ft. (500m) but the cable must not be run parallel to any power line or telephone cables.

The strap-on temperature sensor is designed to be mounted to a pipe by means of the enclosed strap. The brass sensor surface must be in tight contact with the pipe in order to obtain exact temperature measurements. **The strap-on sensor is not intended to be submerged in any liquids.**

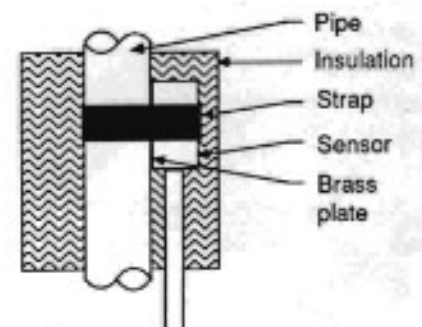

## Adjustments

The only adjustment is to input the setpoint temperature. If the control is to be used only for temperature display purposes then this adjustment does not need to be performed. If an object's temperature will be controlled, then the setpoint adjustment is performed by depressing the red button on the front panel and, rotating the dial until the desired setpoint temperature is displayed. Upon releasing the button, the ambient temperature of the object being measured is displayed again.

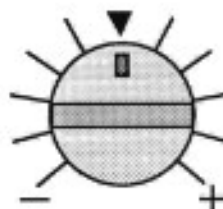

## Testing and Troubleshooting

- Using an ohmmeter, measure the resistance between terminals 15 & 16. The table below lists the expected resistance values at various sensor temperatures. The resistance between ground (the pipes) and terminals 15 & 16 should be greater than 1,000,000 ohms. No voltage should be present between these terminals and ground.
- Turn on the power to the transformer. Using an AC voltmeter, measure between terminals 2 & 3. The voltage should be between 22 and 28 Vac.
- Disconnect the sensor. Terminal L' should short to terminal R1. Place a short where the sensor should be connected. The relay should "click" and terminal L' should short to terminal R2.

Sensor temperature		Resistance	Sensor temperature		Resistance	Sensor temperature		Resistance
°F	°C	ohms	°F	°C	ohms	°F	°C	ohms
-50	-45	59,000	50	10	3,700	150	65	500
-30	-35	33,000	70	20	2,400	170	76	360
-10	-23	17,000	90	32	1,500	190	88	250
10	-12	10,000	110	43	1,000	210	100	180
30	0	5,600	130	54	720	230	110	140

## Limited Warranty

tekmar Control Systems (tekmar®) warrants to the original purchaser, each tekmar product against defects in workmanship and materials, when the product is installed by a qualified person and used in compliance with tekmar's instructions. This warranty covers the cost of parts and labor provided by tekmar to correct defects in material and/or workmanship, but does not cover parts or labor to remove, transport or reinstall the defective product. tekmar will not be liable for any damage other than repair or replacement of the defective part or parts and such repair or replacement shall be deemed to be the sole remedy from tekmar. This warranty shall not apply to any defects caused or repairs required as a result of unreasonable or negligent use, neglect, accident, improper installation, or unauthorized repair or alterations.

In case of defect, malfunction or failure to conform to warranty, tekmar Control Systems will, for 24 months from the date of invoice or for 12 months from the date of installation of the product, whichever occurs first, repair or exchange, at tekmar's

option, the defective product. The warranty is not in effect until the warranty card has been filled out and returned to tekmar Control Systems. Any express or implied warranty which the purchaser may have, including merchantability and fitness for a particular purpose, shall not extend beyond 24 months from the date of invoice or 12 months from the date of installation, whichever occurs first.

### Warranty Procedure

The installer or other qualified service person must, at the owner's expense, determine which component has failed. If an actuating motor, electronic control, mixing valve, pump, sensor, or other tekmar component requires repair, only that component, together with the proof of purchase of the tekmar equipment must be returned to the original purchaser. In order for tekmar to process any warranty claim, the type number and fabrication number of the product and your name and address must be included with the defective component or product.

	<p><b>In North America:</b> tekmar Control Systems, Ltd., Canada tekmar Control Systems, Inc., USA Office: Site 15, Compartment 27, RR #6 Vernon, B.C. CANADA V1T 6Y5 Tel.: (604) 545-7749 Telex: 048-85384 Fax.: (604) 545-0650</p> <p><b>In Europe:</b> tekmar Angewandte Elektronik GmbH &amp; Co. KG Dückerstraße 4 D-4300 Essen 16, WEST GERMANY Tel.: (0201) 49841 Telex: 8579935</p>
--	---