

tekmar[®]

tekmarNet[®] 4 Thermostat 540

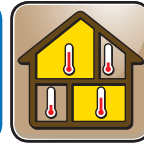

Zoning

D540

12/11

Replaces:08/10

Installation & Operation Manual

Introduction

The tekmarNet[®]4 Thermostat 540 provides operation for:

- One Stage Heat
- One Stage Cool
- One Fan

Features

- Zone Synchronization
- Zone Post Purge
- Intelligent setback (Timer 033)
- Scenes (Away override)
- Auto Heating Cycle
- Cooling Interlock
- tekmarNet[®] 4 communication compatible
- Requires 7 wires
- One stage heat, cool, and fan
- Pulse Width Modulation
- CSA C US Approved for use in USA and Canada
- Outdoor temperature display
- Air Group control
- Backlight
- Freeze Protection
- Equipment Exercising
- Room Temperature Limiting
- Hydronic Cooling
- Supports Radiant Floor Cooling

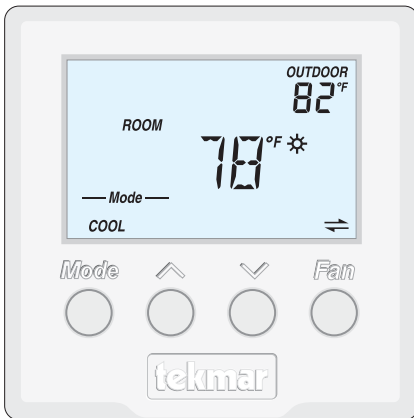

Table of Contents

| | | | |
|-------------------------------------|---|----------------------------------|-------|
| Getting Started | 2 | Settings | 10-17 |
| Installation | 2 | Sequence of Operation..... | 18 |
| Caution..... | 2 | Heating Operation | 18 |
| Preparation..... | 2 | Cooling Operation | 19 |
| Removing The Thermostat Base... | 3 | Floor Cooling..... | 20 |
| Mounting The Thermostat Base.... | 3 | Fan Operation | 21 |
| Thermostat Wiring..... | 4 | Schedules | 22 |
| Testing the Thermostat Wiring | 5 | Scenes (System Override) | 22 |
| Mounting the Thermostat | 6 | Troubleshooting | 23 |
| Cleaning the Thermostat..... | 6 | Error Messages..... | 23-24 |
| Switch Settings | 7 | Frequently Asked Questions | 25 |
| User Interface..... | 8 | Job Record..... | 26 |
| Display..... | 8 | Technical Data..... | 27 |
| Symbols Description | 8 | Limited Warranty and Product | |
| Button Operation | 9 | Return Procedure | 28 |

Getting Started

Congratulations on the purchase of your new tekmar thermostat.

This manual will step through the complete installation, programming and sequence of operation for this control. At the back, there are tips for control and system troubleshooting.

Installation

Caution

Improper installation and operation of this control could result in damage to the equipment and possibly even personal injury or death. It is your responsibility to ensure that this control is safely installed according to all applicable codes and standards. This electronic control is not intended for use as a primary limit control. Other controls that are intended and certified as safety limits must be placed into the control circuit.

Preparation

Tools Required

- tekmar or jeweller screwdriver
- Wire Stripper
- Phillips head screwdriver

Materials Required

- 2, #6 x 1" Wood Screws
- 18 AWG LVT Solid Wire (Low Voltage Connections)
- Optional Adapter Plate 007 (for installation on 2" x 4" gang box)

Installation Location

Choose the placement of the thermostats early in the construction process to enable proper wiring during rough-in.

Consider the following:

- Interior Wall.
- Keep dry. Avoid potential leakage onto the control.
- Relative Humidity max 92% up to 104°F (40°C), 50% RH above 104°F (40°C). Non-condensing environment.
- No exposure to extreme temperatures beyond 36-122°F (2-50°C).
- No draft, direct sun, or other cause for inaccurate temperature readings.
- Away from equipment, appliances, or other sources of electrical interference.
- Easy access for wiring, viewing, and adjusting the display screen.
- Approximately 5 feet (1.5 m) off the finished floor.
- The maximum length of wire is 500 feet (150 m).
- Strip wire to 3/8" (10 mm) for all terminal connections.
- Use standard 8 conductor, 18 AWG wire.

Removing The Thermostat Base

To remove the thermostat base:

- Place a small slot screwdriver or similar tool into the slot located on the top of the thermostat.
- While pushing down against the plastic tab, pull the thermostat away from the thermostat's base.

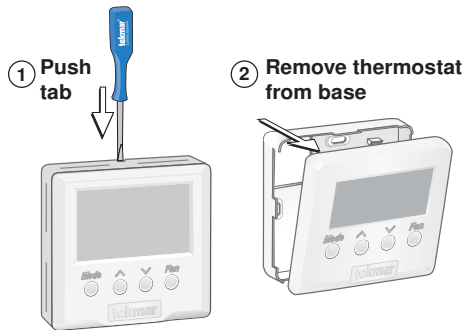

Mounting The Thermostat Base

If a single gang switch box is used, an Adaptor Plate 007 is required to mount the thermostat to the box.

- Fasten the base of the thermostat to the adaptor plate.
- Feed the wiring through the openings in the back of the adaptor plate and thermostat.
- Use the upper and lower screw holes to fasten the adaptor plate to the box.

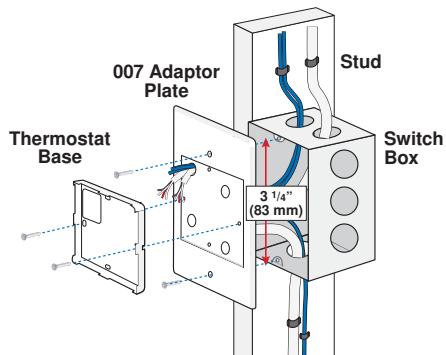

Mounted on switch box

If a switch box was not used, mount the thermostat directly to the wall.

- Feed the wiring through the openings in the back of the thermostat.
- Use screws in the screw holes to fasten the thermostat to the wall. At least one of the screws should enter a wall stud or similar rigid material.

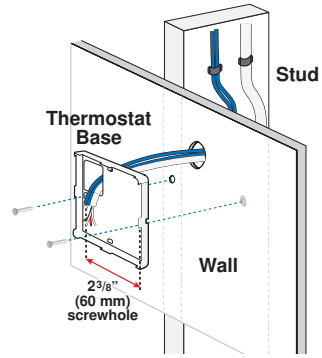

Mounted on wallboard

Thermostat Wiring

The thermostat operates a single heating system zone together with a cooling system and fan.

Connect tN4, C, R, and W terminals on the thermostat to the tN4, C, R and W terminals on the tN4 Wiring Center or Zone Manager.

Connect the Rc, Y and G terminals on the thermostat to the R, Y and G terminals on the cooling equipment.

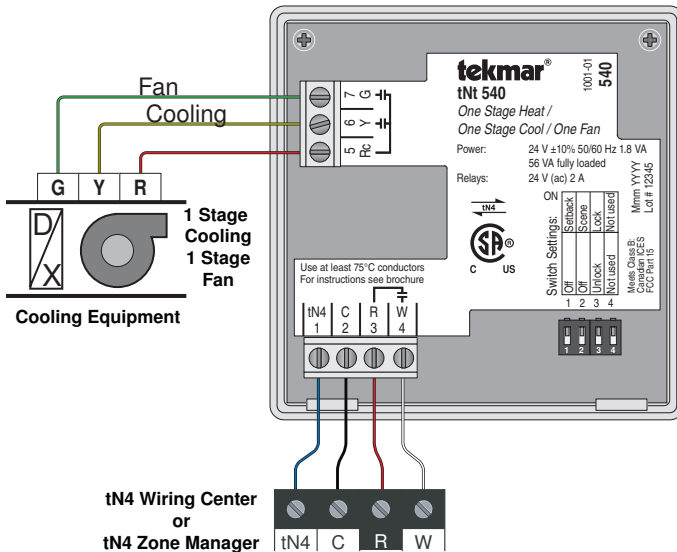

Testing the Thermostat Wiring

Testing the Power

1. Remove the front cover from the thermostat.
2. Use an electrical test meter to measure (ac) voltage between the R and C terminals. The reading should be 24 V (ac) +/- 10%.
3. Install the front cover.

Testing the Heat, Cool, and Fan Relays

1. Remove the front cover from the thermostat.
2. Press Mode button until Mode is set to OFF.
3. Set the electrical test meter to continuity.
4. Place probes between R (3) and W (4), then between Rc (5) and Y (6). In both cases there should be no continuity. If there is continuity then there may be a wiring fault or the relay may be faulty.
5. Press Mode button until Mode is set to HEAT.
6. Press the **▲** button and set the heating temperature above the current room temperature. Make sure the display does not show "WWSD". The "H1" symbol should appear on the display.
7. There should be continuity between the R (3) and W (4) terminals.
8. Press Mode button until Mode is set to COOL.
9. Press the **▼** button and set the cooling temperature below the current room temperature. The "C1" symbol should appear on the display.
10. There should be continuity between the Rc (5) and Y (6) terminals.
11. Press Fan button to set the fan to Auto.
12. Ensure the fan symbol is not shown on the display.
13. There should be no continuity between Rc (5) and G (7) terminals.
14. Press Fan button to set the fan to On.
15. The "Fan" symbol should appear on the display.
16. There should be continuity between the Rc (5) and G (7) terminals.

Testing the tekmarNet®4 Bus

The ⇄ symbol is shown on the display when communication is present. If the thermostat is connected in a network and the communication is missing, there may be an open or short circuit on the tN4 and C bus wires.

1. Remove the front cover from the thermostat.
2. To test for short circuits:
 - Disconnect the tN4 bus wires on one end.
 - Install wire nuts on each wire to ensure the wire ends are not touching.
 - Disconnect the tN4 bus wires on the other end.
 - Measure for continuity using an electrical meter.
 - If continuity is present, there is a short circuit fault along the wires. It is recommended to replace the tN4 bus wires.
3. To test for open circuits:
 - Disconnect the tN4 bus wires on one end and connect them together.
 - Disconnect the tN4 bus wires on the other end.
 - Use an electrical meter to measure for continuity.
 - If there is no continuity, there is an open circuit fault along the wires. It is recommended to replace the tN4 bus wires.

Mounting the Thermostat

To place the thermostat back on the mounting base:

- Place thermostat bottom tabs on matching mounting base notches.
- Pivot top of the thermostat towards wall, ensuring wires clear obstructions.
- The top clasp makes a clicking sound when properly closed.

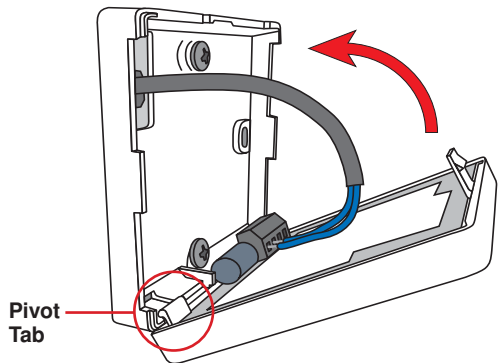

Cleaning the Thermostat

The thermostat's exterior can be cleaned using a damp cloth. Moisten the cloth with water and wring out prior to wiping the control. Do not use solvents or cleaning solutions.

User Interface

Display

MAIN DISPLAY SECONDARY DISPLAY

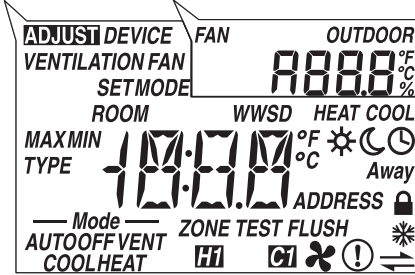

Switch between Heat, Cool, Auto and Off modes

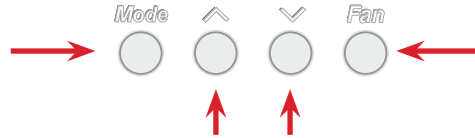

Switch between Auto, On and % Fan operation

Adjust the current temperature or displayed setting up or down

Symbols Description

| | | | |
|--|--|--------------|---|
| | HEAT Heat is turned on. | | CLOCK Operating on a programmable schedule. |
| | COOL Cooling is turned on. | | LOCK Locked to 'User' access level. |
| | FAN Fan is turned on. | Away | Operating at the <i>Away</i> scene temperature. |
| | SUN Operating at the occupied (day) temperature. | | tekmarNet® Communication is present. |
| | MOON Operating at the unoccupied (night) temperature. | | WARNING SYMBOL Indicates an error is present. |
| | AIR GROUP MASTER Thermostat operates the cooling for a group of thermostats. | WWS D | WARM WEATHER SHUT DOWN The heating system has been shut off for the summer. |

Button Operation

Mode

The Mode button selects between Auto, Cool, Heat, and Off.

Heat Mode: The heating system operates to maintain the Set Room Heat temperature.

Cool Mode: The cooling system operates to maintain the Set Room Cool temperature.

Auto Mode: The heating system operates to maintain the Set Room Heat temperature. Likewise the cooling system operates to maintain the Set Room Cool temperature. The thermostat will prevent the Set Room Heat and the Set Room Cool settings from getting closer than 3°F (1.5°C).

To switch from heating to cooling, the heat must be off for at least a 30 minute interlock period and the actual Room temperature must be at least 3°F (1.5°C) above the Set Room Heat temperature.

To switch from cooling to heating, the cooling must be off for at least a 30 minute interlock period and the Room temperature must be at least 3°F (1.5°C) below the Set Room Cool temperature. Cooling has priority over heating.

Off Mode: The heating and cooling are shut off except heating for freeze protection.

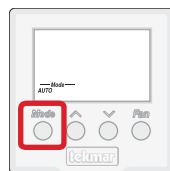

Room \wedge or \vee Temperature

Press the \wedge or the \vee button to select the room temperature. The display indicates whether the "HEAT" or the "COOL" temperature is being changed.

If in Auto mode, press the Mode button to toggle between Heat or Cool temperature adjustment.

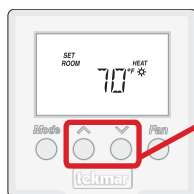

Use the \wedge or \vee button to adjust temperature.

Fan

The fan button manually turns the fan on or off.

Auto: Fan is usually off but can operate with heating or cooling.

On: Fan is on all the time.

10 to 90%: Fan operates a minimum of this percentage each hour.

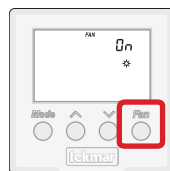

Settings (1 of 8)

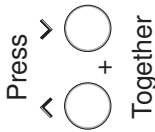

- Press and hold down both the ▲ and ▼ buttons for 2 seconds to change from one step to the next.
- Release both buttons once the step has been reached.
- Press the ▲ or the ▼ button to change the setting, if available.
- Press and hold down both the ▲ and ▼ buttons for 2 seconds to go to the next step, OR
- After 10 seconds of no button activity, the display goes back to normal operation.
- **Note:** Set switch setting #3 and tekmarNet® system control to Unlock to change Access level to Installer.

| Display | Range | Access | Description | Set to |
|---------|---|-------------------|---|--------|
| | 40 to 95°F (4.5 to 35.0°C) Default = 70°F (21.0°C) | Installer User | SET ROOM HEAT ☀ Set the room heating temperature while in the ☀ event. | |
| | 40 to 95°F (4.5 to 35.0°C) Default = 65°F (18.5°C) | Installer User | SET ROOM HEAT ☾ Set the room heating temperature while in the ☾ event. | |
| | 40 to 95°F (4.5 to 35.0°C) Default = 62°F (16.5°C) | Installer | SET ROOM HEAT AWAY Set the room heating temperature while in the <i>Away</i> scene. | |



Continued on next page.

Settings (2 of 8)

| Display | Range | Access | Description | Set to |
|---|---|-------------------|--|--------|
| <p>ADJUST SET ROOM 79.0 COOL</p> | 50 to 100° F (10.0 to 38.0 °C) Default = 78° F (25.5° C) | Installer User | SET ROOM COOL ☀ Set the room cooling temperature while in the ☀ event. | |
| <p>ADJUST SET ROOM 85.0 COOL</p> | 50 to 100° F (10.0 to 38.0 °C) Default = 85° F (29.5° C) | Installer User | SET ROOM COOL ☾ Set the room cooling temperature while in the ☾ event. | |
| <p>ADJUST SET ROOM 85.0 COOL Away</p> | 50 to 100° F (10 to 38.0° C) Default = 85° F (29.5° C) | Installer | SET ROOM COOL AWAY Set the room cooling temperature while in the Away scene. | |
| <p>ADJUST 30 11-E</p> | Off, 30 sec, On, On + ☀ Default = 30 sec | Installer User | BACKLIGHT Select the backlight operation. Off = Permanently Off 30 = Temporary on for 30 seconds On = Permanently On On + ☀ = On during ☀ and off during ☾ | |

Continued on next page.

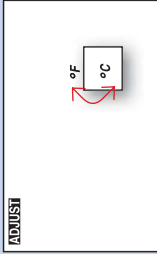
Settings (3 of 8)

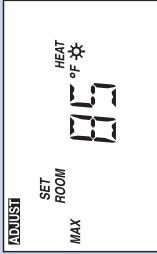
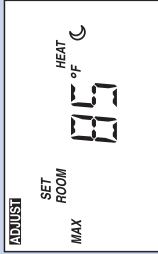
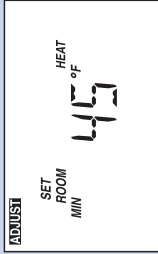
| Display | Range | Access | Description | Set to |
|---|---|---------------------------|--|--------|
|  | <p>°F or °C Default = °F</p> | <p>Installer User</p> | <p>TEMPERATURE UNITS Press the ^ or the v button to change from °F to °C and vice versa.</p> | |
|  | <p>Device Type with Software Version, Address</p> | <p>Installer User</p> | <p>DEVICE TYPE Display alternates between the Device Type (large number) with Software Version (upper right corner) and the thermostat address.</p> | |
|  | <p>40 to 95°F (4.5 to 35.0°C) Default = 85°F (29.5°C)</p> | <p>Installer</p> | <p>MAXIMUM SET ROOM HEAT ☀ Set the maximum room heating limit while in the ☀ event.</p> | |
|  | <p>40 to 95°F (4.5 to 35.0°C) Default = 85°F (29.5°C)</p> | <p>Installer</p> | <p>MAXIMUM SET ROOM HEAT ☾ Set the maximum room heating limit while in the ☾ event.</p> | |
|  | <p>40 to 95°F (4.5 to 35.0°C) Default = 45°F (7.0°C)</p> | <p>Installer</p> | <p>MINIMUM SET ROOM HEAT Set the minimum room heating limit.</p> | |



Continued on next page.

Settings (4 of 8)

| Display | Range | Access | Description | Set to |
|---------|---|-----------|--|--------|
| | 50 to 100° F (10 to 38.0 °C) Default = 60° F (15.5° C) | Installer | MINIMUM SET ROOM COOL Set the minimum room cooling limit. | |
| | 50 to 100° F (10.0 to 38.0 °C) Default = 95° F (35.0° C) | Installer | MAXIMUM SET ROOM COOL Set the maximum room cool limit. | |
| | OFF, On Default = OFF | Installer | VENTILATION Select whether or not ventilation is required. Setting to on allows the fan to be operated in 10% increments every hour to circulate air in the building. | |
| | 0, 1, 2, 3 Default = 1 | Installer | FAN MODE Select how the fan should operate together with heating and cooling. 0 = Manual operation only 1 = Operate fan with cooling only 2 = Operate fan with heating and cooling 3 = Operate fan with heating only | |

Continued on next page.

Settings (5 of 8)

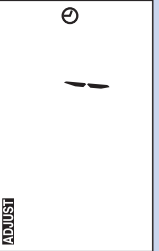
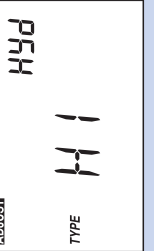
| Display | Range | Access | Description | Set to |
|---|---|-------------------|--|--------|
|  | Auto, 10 to 90%, On Default = Auto | Installer User | FAN * Set the minimum percentage the fan should operate while in the * event. This provides ventilation for the building. Each 10% is 6 minutes per hour. Available when: <ul style="list-style-type: none"> • Ventilation is set to On. | |
|  | Auto, 10 to 90%, On Default = Auto | Installer User | FAN ☾ Set the minimum percentage the fan should operate while in the ☾ event. This provides ventilation for the building. Each 10% is 6 minutes per hour. Available when: <ul style="list-style-type: none"> • Ventilation is set to On. | |
|  | 1, 2, 3, 4 Default = 1 | Installer | SCHEDULE Thermostat can follow schedule master 1, 2, 3, or 4. Available when: <ul style="list-style-type: none"> • Switch setting 1 is set to Setback (On Position). | |
|  | Hyd (Hydronic) or Oth (Other) Default = Hydronic | Installer | HEAT TERMINAL TYPE Select if the heating for this zone is hydronic or non-hydronic (other). Available when: <ul style="list-style-type: none"> • A reset control is present on the tekmarNet® system. | |



Continued on next page.

Settings (6 of 8)

| Display | Range | Access | Description | Set to |
|--|--|------------------|--|--------|
| <p>The display shows 'HEAT SUPPLY' at the top, 'PUMP' in large letters in the middle, and 'On' at the bottom.</p> | <p>OFF or On Default = On</p> | <p>Installer</p> | <p>HEAT SUPPLY PUMP During heating, select whether or not the system supply pump should turn on or be off to allow a zone group pump per manifold. Available when: • A reset control is present on the tekmarNet® system AND Heating terminal type is set to Hydronic.</p> | |
| <p>The display shows 'HEAT SUPPLY' at the top, 'PUMP DELAY' in large letters in the middle, and 'OFF' at the bottom.</p> | <p>OFF or On Default = OFF</p> | <p>Installer</p> | <p>HEAT SUPPLY PUMP DELAY During heating, select whether or not the system supply pump should be delayed by 3 minutes before coming on (for thermal motor or wax actuator). Available when: • A reset control is present on the tekmarNet® system AND Heating terminal type is set to Hydronic.</p> | |
| <p>The display shows 'COOL TERMINAL' at the top, 'TYPE' in small letters below it, and 'rEF' in large letters in the middle.</p> | <p>rEF, Coil, H1 Default = rEF</p> | <p>Installer</p> | <p>COOL TERMINAL TYPE Select the type of cooling system operated. rEF = DX refrigerant coil Coil = Hydronic coil H1 = Hydronic cooling using the heating terminal unit Coil and H1 are available when: • A heat pump or chiller tekmarNet® system control is present.</p> | |

Continued on next page.

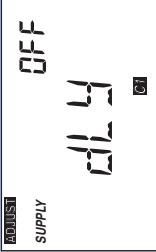
Settings (7 of 8)

| Display | Range | Access | Description | Set to |
|---|---|------------------|--|--------|
|  | <p>OFF or On Default = On</p> | <p>Installer</p> | <p>COOL SUPPLY PUMP During cooling, select whether or not the system supply pump should turn on or be off to allow a zone group pump per manifold. Available when: <ul style="list-style-type: none"> A reset control is present on the tekmarNet® system AND Cool terminal type is set to Coil. </p> | |
|  | <p>OFF or On Default = OFF</p> | <p>Installer</p> | <p>COOL SUPPLY PUMP DELAY During cooling, select whether or not the system supply pump should be delayed by 3 minutes before coming on (for thermal motor or wax actuator). Available when: <ul style="list-style-type: none"> A reset control is present on the tekmarNet® system AND Cool terminal type is set to Coil. </p> | |
|  | <p>Auto, SYn(Synchronize) Default = Synchronize</p> | <p>Installer</p> | <p>HEAT CYCLES PER HOUR Select either Auto cycle or Synchronize with other thermostats on the tekmarNet® system. Choose Synchronize when zone heated using a boiler. Choose Auto when zone is non-hydrionic heating. Available when: <ul style="list-style-type: none"> No reset control on the tekmarNet® system. </p> | |

Continued on next page.

Settings (8 of 8)

| Display | Range | Access | Description | Set to |
|------------------------------|--|-------------------|--|--------|
| <p>AIRB OFF</p> | OFF, 1 to 16 | Installer | <p>AIR GROUP</p> <p>Select if this thermostat should be an air group master. Select off if the thermostat is not an air group master. Select 1 through 16 to select the air group number.</p> <p>Available when:</p> <ul style="list-style-type: none"> The thermostat is connected to other thermostats using tekmarNet®. | |
| <p>Auto b:01 ADDRESS</p> | 01 to 24 (no reset control), b:01 to b:24 (reset control - boiler), 1:01 to 1:24 (reset control - mixing) | Installer | <p>tekmarNet® ADDRESS</p> <p>The address is shown in the large number field. "Auto" is shown in the upper number field when using automatic addressing.</p> <p>Press the ▲ or the ▼ button to manually select an address.</p> <p>The address can be returned to automatic "Auto" addressing when address set above 24.</p> | |
| <p>FLOOR OFF COOL</p> | OFF or On Default = OFF | Installer | <p>FLOOR COOLING</p> <p>Select if the thermostat should operate the heating relay W for radiant floor cooling.</p> <p>Available when:</p> <ul style="list-style-type: none"> Connected to a tekmarNet® heat pump or chiller system control AND heating terminal type is set to Hydronic AND cooling terminal type is set to rEF or COIL. | |
| <p>ESC</p> | None | Installer User | <p>ESCAPE</p> <p>Press the ▲ or the ▼ button to return to normal operation.</p> | |

Sequence of Operation

Heating Operation

Section A

The thermostat operates the heating system to maintain the Set Room Heat temperature. The H1 symbol is shown on the display when the thermostat is heating. The heat can cycle on and off within +/- 1.5°F (1°C) of the Set Room Heat temperature.

Freeze Protection

The thermostat operates the heat whenever the room temperature falls below 40°F (4.5°C), regardless of the thermostat mode.

Heat Terminal Unit

When the thermostat is connected to a tekmarNet® reset control, the heat source can be either hydronic or non-hydronic.

When the Heat Terminal is set to Hydronic, the thermostat uses indoor temperature feedback to fine tune the water temperature and also synchronizes the start of a heating cycle so that all thermostats start heating at the same time. This reduces cycling on the boiler.

When the Heat Terminal is set to Other, the thermostat does not use indoor temperature feedback. This allows the thermostat to operate non-hydronic heating systems (example: furnace, electric baseboard, or electric fan coil), while remaining connected to the tekmarNet® system.

Exercising

When connected to a tekmarNet® reset control, and the heating terminal unit is set to hydronic, the thermostat exercises the heat relay for 10 seconds every 3 days. Exercising helps prevent zone valves or zone pumps from failing due to precipitate buildup. During exercising, the thermostat shows “TEST” on the display.

Flushing

The flushing feature is for open-loop systems that use a domestic hot water tank as a heat source. Flushing ensures that fresh potable water is circulated through the system once each day. If the thermostat is connected to a tekmarNet® reset control with the Flushing feature turned on, the thermostat display will display the “FLUSH” icon for the duration of the flushing operation.

Hydronic System Supply Pump

When connected to a tekmarNet® system control, the thermostat's Heat Supply Pump setting affects how the primary pump or mix pump on the system control operates. When connected to the boiler bus, the boiler system or primary pump is operated. When connected to the mix bus, the mix system pump is operated.

If the thermostat operates a motorized or thermal motor zone valve, the Heat Supply Pump setting should be set to On.

If the thermostat operates a thermal motor (wax actuator) zone valve, set the Heat Supply Pump Delay setting to On. This provides a three minute delay to allow the zone valve to open before the primary or mix pump is turned on.

In special applications with multiple zoning manifolds, the Heat Supply Pump setting can be set to Off. This allows a Zone Group Pump located on the Zone Manager, or Wiring Center to operate the pump for the manifold.

DHW Tank Priority

When a tekmarNet® reset control is heating an indirect Domestic Hot Water (DHW) tank, the thermostat may shut off the heating zones to allow the DHW tank to recover quickly. This is determined by the DHW priority of the tekmarNet® reset control.

Warm Weather Shut Down

When the outdoor air temperature exceeds the Warm Weather Shut Down (WWSD) setting on the tekmarNet® reset control, the heating system is shut off.

Cooling Operation

Section B

The thermostat operates the cooling system to maintain the Set Room Cool temperature. The C1 symbol is shown on the display when the thermostat is cooling. The cooling can cycle on and off within +/- 1.5°F (1°C) of the Set Room Cool temperature.

The cooling system has a fixed minimum on time of 2 minutes and a minimum off time of 5 minutes in order to prevent cooling equipment short cycling.

Air Groups

In order to prevent heating and cooling at the same time, this thermostat can operate together with other thermostats on a tekmarNet® system to form an air group. There can be up to 16 different air groups on the same HVAC system. When this thermostat is set as the Air Group master, it operates the cooling equipment for the group. Other thermostats can be set to become members of the same air group. When the cooling is turned on, all air group member thermostats ensure the heating is off. When operating as an air group, the air temperature readings of all the air group member thermostats are displayed on the master as an average.

The air group average temperature is shown as the “Room” temperature while the mode is set to Cool, or the mode is set to Auto and the thermostat is allowing cooling operation. In all other modes, the air group master thermostat measures and displays the built-in “local” temperature sensor measurement.

Fluctuations in the displayed “Room” temperature may occur during automatic mode switch over when the display changes from using the local temperature for heating to using the air group average member temperature for cooling.

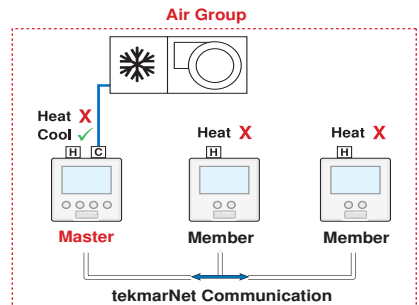

Hydronic Cooling

The thermostat has the option to support hydronic cooling using a fan coil or a chilled beam when connected to a heat pump or chiller tekmarNet® system control.

When operating a chilled beam or a fan coil that uses chilled water for cooling but does not use hot water for heating, then the Cool Terminal Type should be set to Coil. The thermostat activates the Y terminal and also provides a cooling call to the heat pump or chiller control through the tekmarNet® communication.

When operating a fan coil that uses both hot and chilled water, then the Cool Terminal Type should be set to H1. The thermostat activates both the Y terminal and the heating terminal device (zone valve or zone pump), as well as provides a cooling call to the heat pump or chiller control through the tekmarNet® communication.

Hydronic System Supply Pump

When connected to a tekmarNet® system control, the thermostat's Cool Pump setting affects how the primary pump or mix pump on the system control operates during cooling operation. When connected to the boiler bus, the boiler system or primary pump is operated. When connected to the mix bus, the mix system pump is operated.

If the thermostat operates a motorized or thermal motor zone valve, the Cool Supply Pump setting should be set to On.

If the thermostat operates a thermal motor (wax actuator) zone valve, set the Cool Supply Pump Delay setting to On. This provides a three minute delay to allow the zone valve to open before the primary or mix pump is turned on.

In special applications with multiple zoning manifolds, the Cool Supply Pump setting can be set to Off. This allows a Zone Group Pump located on the Zone Manager, or Wiring Center to operate the pump for the manifold.

Floor Cooling

Section C

The thermostat has the option to support radiant floor cooling when connected to a heat pump control using tekmarNet® communication. The heating terminal unit type must be set to be hydronic (HYD), the floor cooling setting must be set to On and the heating system must be in Warm Weather Shut Down (WWSD). When the heat pump system control operates in cooling mode, all thermostats set for floor cooling on the tekmarNet® bus all activate the first stage heating contact (H1) at the same time to allow chilled water into the system. The thermostat continues to operate the cooling until either the room temperature reaches the Set Heat temperature plus 3°F (Set Heat+1.5°C) or reaches a minimum temperature of 74°F. If only a floor sensor is installed, the floor cooling setpoint is 67°F (19.5°C).

The thermostat normally operates the fan together with the heating and cooling systems. This is determined by the Fan Mode setting in the Adjust menu.

| Fan Mode | The fan operates with... |
|----------|---|
| 0 | Not With Heating Nor Cooling (Only with fan button) |
| 1 | Cooling Only |
| 2 | Heating and Cooling |
| 3 | Heating Only |

The fan relay includes a post purge feature. After the heating is shut off, the fan continues to operate for 30 seconds. After the cooling is shut off, the fan continues to operate for 10 seconds.

The user can also select to operate the fan manually by pressing the Fan button. This allows the user to choose between Auto and On. "Auto" allows the fan to operate together with heating or cooling but normally the fan is off. "On" forces the fan to operate continuously.

The fan button is inactive when the Fan Mode is 0 and Ventilation is set to Off.

Ventilation Fan

In order to provide ventilation to the building, the fan can also operate for additional time beyond what is required for the heating and cooling systems. Ventilation allows the user to select the fan to operate for a minimum percentage out of each hour. Options are 10 to 90%, in 10% (6 minutes per hour) increments, as well as Auto and On. This is available when the Ventilation setting in the Adjust menu is set to On.

Once Ventilation is set to On, the Fan minimum run time percentage during the ☼ and ☾ events can be set so that the fan can operate on a schedule and/or together with scenes.

Lowering the room temperature setting reduces the amount of fuel required to heat the building resulting in energy savings. Likewise, raising the cooling temperature results in energy savings.

This thermostat can follow a programmable schedule in order to automatically lower the room temperature setting. A schedule master such as a Timer 033 is required in order to gain programmable schedule functionality.

When operating on a programmable schedule, a ☰ symbol is shown, as well as a ☀ or a ☾. The ☀ or ☾ indicates the current operating temperature.

If a ☰ symbol does not appear, there is no schedule available.

| Display | Action |
|---------|--|
| ☀ | Occupied temperature. No schedule. |
| ☾ | Unoccupied temperature. No schedule. |
| ☀ ☰ | Programmable schedule at occupied temperature. |
| ☾ ☰ | Programmable schedule at unoccupied temperature. |

When a programmable schedule is selected, there is a time delay for the temperature to change from the ☾ temperature to the ☀ temperature.

The thermostat uses Optimum Start to predict the heat up and cool off rate of the room. The optimum start feature allows the room to reach the set room ☀ temperature by the time set in the programmable schedule. This applies for both heating and cooling.

Scenes (System Override)

Section F

Scenes provide an easy way to save energy while away on vacation, or override a pre-set schedule when plans change. tekmarNet® devices such as a User Switch 479 provide scene adjustment.

This thermostat responds to the following scenes:

| Scene | Display | Room Temperature Setting |
|-------|-----------------|--|
| 1 | ☀ or ☀ ☰ or ☾ ☰ | Follows programmable schedule or operates at the occupied ☀ temperature. |
| 2 | Away | Away temperature. |
| 3 | ☾ | Unoccupied ☾ temperature. |

While in the *Away* scene, the room temperature cannot be changed using the ^ or v buttons. Change the scene from *Away* to ☀ or ☾ to change the temperature.

Troubleshooting

Error Messages (1 of 2)

Error Message

Description

CONTROL ERROR

The thermostat was unable to correctly read settings from memory and has reloaded the factory default settings. The thermostat does not operate the heating, cooling, or the fan while this error message is present.

Error clears once all adjust menu settings in the Installer access level (unlocked) have been checked. Set thermostat's switch setting #3 to unlock and unlock the tekmarNet® system control. Then press and hold **▲** and **▼** buttons together for 2 seconds to enter the adjust menu. Continue until all settings have been reviewed.

BUS ERROR

The tekmarNet®4 communication bus has either an open or a short circuit. The result is that there are no communications. Check for loose wires. Check for short circuits between the tN4 and C wires on the House Control, Wiring Center, or Zone Manager. Check for correct polarity between the C and R wires.

Error clears automatically once wiring fault has been corrected.
If the thermostat is intentionally removed from the tekmarNet®4 bus, press the **▲** and **▼** buttons together to clear the error message.

DEVICE LIMIT

The number of devices on the tekmarNet® bus has exceeded 24. Devices include tekmarNet® Thermostats and Setpoint Controls. The device count must be lowered to 24 or less. If possible, move devices to other tekmarNet® buses.

Error clears automatically once the number of devices on the tekmarNet® bus is at 24 or lower.

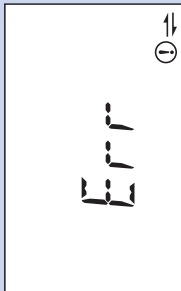
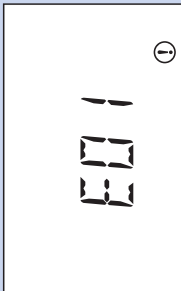

Error Messages (2 of 2)

Error Message

Description

ADDRESS ERROR

This thermostat and another device have been manually given the same tekmarNet® address. Error clears automatically once this thermostat is given a new manually set address or if the thermostat is set to automatic addressing.

Err
ADDRESS
①

ROOM SENSOR SHORT CIRCUIT

The built-in air temperature sensor has a short circuit fault. This error cannot be field repaired. Contact your wholesaler or tekmar sales representative for details on repair procedures.

ROOM/SENSOR
SHR
①

ROOM SENSOR OPEN CIRCUIT

The built-in air temperature sensor has an open circuit fault. This error cannot be field repaired. Contact your wholesaler or tekmar sales representative for details on repair procedures.

ROOM/SENSOR
OPN
①

AIR MASTER ERROR

There are two thermostats on the tekmarNet® system set as the same Air Group master. The cooling system will not operate while this error message is present. Error clears once this thermostat or the other thermostat's air group master number is changed to an unused air group number.

Err
M51
cool
①

Frequently Asked Questions

| Symptom | Look for... | Corrective Action |
|---|---|---|
| No Heat | H1 Symbol | H1 symbol indicates heat is on. Check if zone valve or zone pump is operating. |
| | Flashing WWSD | Increase WWSD setting on tekmarNet® reset control. |
| | Flashing Away | Change User Switch to Normal scene 1. |
| | Mode Auto or Heat | Press Mode button to Auto or Heat mode. |
| No Cooling | C1 Symbol | C1 symbol indicates cooling is on. Check if cooling relay and cooling equipment are operating. |
| | Flashing Away | Change User Switch to Normal scene 1. |
| | Mode Auto or Cool | Press Mode button to Auto or Cool mode. |
| Heat or Cooling on yet Fan off | Fan symbol | Fan symbol indicates fan is on. Check if fan relay and fan equipment is operating. |
| | Fan set to Off | Ensure fan mode is set correctly. |
| Heat or cooling on before scheduled time |  | Optimum start “learns” the heat up and cool off rate of the room and starts the heating or cooling early so that the room is comfortable at the scheduled time. |
| Pressing ▲ button does not increase temperature | Flashing Max | Installer can increase the Maximum Set Room Heat or Maximum Set Room Cool limits. |
| Pressing ▼ button does not decrease temperature | Flashing Min | Installer can decrease the Minimum Set Room Heat or Minimum Set Room Cool limits. |

Job Record

Jobsite Location _____

Thermostat Location _____

| Item | Setting | Item | Setting |
|---------------------|---------|------------------------|---------|
| Set Room Heat ☀ | | Fan Mode | |
| Set Room Heat ☾ | | Fan ☀ | |
| Set Room Heat Away | | Fan ☾ | |
| Set Room Cool ☀ | | Schedule Member | |
| Set Room Cool ☾ | | Heat Terminal Type | |
| Set Room Cool Away | | Heat Supply Pump | |
| Backlight | | Heat Supply Pump Delay | |
| Units | | Cool Terminal Type | |
| Max Set Room Heat ☀ | | Cool Supply Pump | |
| Max Set Room Heat ☾ | | Cool Supply Pump Delay | |
| Min Set Room Heat | | Heat Cycles Per Hour | |
| Min Set Room Cool | | Air Group | |
| Max Set Room Cool | | tekmarNet® Address | |
| Ventilation | | Floor Cooling | |

Technical Data

tekmarNet[®]4 Thermostat 540; One Stage Heat, One Stage Cool, One Fan

| | |
|--------------------|---|
| Packaged weight | 0.8 lb. (380 g) |
| Enclosure | NEMA 1, white PVC plastic |
| Dimensions | 2-7/8" H x 2-7/8" W x 13/16" D (73 x 73 x 21 mm) |
| Approvals | CSA C US, meets Class B: ICES and FCC Part 15 |
| Ambient conditions | Indoor use only, 36 to 122°F (2 to 50°C). |
| | RH max 92% to 104°F (40°C), and 50% above 104°F (40°C) |
| | Altitude <9840 feet (3000 m), Installation Category II, Pollution Degree 2 |
| Power supply | 24 V (ac) ± 10% 50/60 Hz, 1.8 VA Standby, 56 VA fully loaded, NEC / CEC Class 2 |
| W, Y and G Relays | 24 V (ac) 2 A |

Limited Warranty and Product Return Procedure

Limited Warranty *The liability of tekmar under this warranty is limited. The Purchaser, by taking receipt of any tekmar product ("Product"), acknowledges the terms of the Limited Warranty in effect at the time of such Product sale and acknowledges that it has read and understands same.*

The tekmar Limited Warranty to the Purchaser on the Products sold hereunder is a manufacturer's pass-through warranty which the Purchaser is authorized to pass through to its customers. Under the Limited Warranty, each tekmar Product is warranted against defects in workmanship and materials if the Product is installed and used in compliance with tekmar's instructions, ordinary wear and tear excepted. The pass-through warranty period is for a period of twenty-four (24) months from the production date if the Product is not installed during that period, or twelve (12) months from the documented date of installation if installed within twenty-four (24) months from the production date.

The liability of tekmar under the Limited Warranty shall be limited to, at tekmar's sole discretion: the cost of parts and labor provided by tekmar to repair defects in materials and / or workmanship of the defective product; or to the exchange of the defective product for a warranty replacement product; or to the granting of credit limited to the original cost of the defective product, and such repair, exchange or credit shall be the sole remedy available from tekmar, and, without limiting the foregoing in any way, tekmar is not responsible, in contract, tort or strict product liability, for any other losses, costs, expenses, inconveniences, or damages, whether direct, indirect, special, secondary, incidental or consequential, arising from ownership or use of the product, or from defects in workmanship or materials, including any liability for fundamental breach of contract.

The pass-through Limited Warranty applies only to those defective Products returned to tekmar during the warranty period. This Limited Warranty does not cover the cost of the parts or labor to remove or transport the defective Product, or to reinstall the repaired or replacement Product, all such costs and expenses being subject to Purchaser's agreement and warranty with its customers.

Any representations or warranties about the Products made by Purchaser to its customers which are different from or in excess of the tekmar Limited Warranty are the Purchaser's sole responsibility and obligation. Purchaser shall indemnify and hold tekmar harmless from and against any and all claims, liabilities and damages of any kind or nature which arise out of or are related to any such representations or warranties by Purchaser to its customers.

The pass-through Limited Warranty does not apply if the returned Product has been damaged by negligence by persons other than tekmar, accident, fire, Act of God, abuse or misuse; or has been damaged by modifications, alterations or attachments made subsequent to purchase which have not been authorized by tekmar; or if the Product was not installed in compliance with tekmar's instructions and / or the local codes and ordinances; or if due to defective installation of the Product; or if the Product was not used in compliance with tekmar's instructions.

THIS WARRANTY IS IN LIEU OF ALL OTHER WARRANTIES, EXPRESS OR IMPLIED, WHICH THE GOVERNING LAW ALLOWS PARTIES TO CONTRACTUALLY EXCLUDE, INCLUDING, WITHOUT LIMITATION, IMPLIED WARRANTIES OF MERCHANTABILITY AND FITNESS FOR A PARTICULAR PURPOSE, DURABILITY OR DESCRIPTION OF THE PRODUCT, ITS NON-INFRINGEMENT OF ANY RELEVANT PATENTS OR TRADEMARKS, AND ITS COMPLIANCE WITH OR NON-VIOLATION OF ANY APPLICABLE ENVIRONMENTAL, HEALTH OR SAFETY LEGISLATION; THE TERM OF ANY OTHER WARRANTY NOT HEREBY CONTRACTUALLY EXCLUDED IS LIMITED SUCH THAT IT SHALL NOT EXTEND BEYOND TWENTY-FOUR (24) MONTHS FROM THE PRODUCTION DATE, TO THE EXTENT THAT SUCH LIMITATION IS ALLOWED BY THE GOVERNING LAW.

Product Warranty Return Procedure All Products that are believed to have defects in workmanship or materials must be returned, together with a written description of the defect, to the tekmar Representative assigned to the territory in which such Product is located. If tekmar receives an inquiry from someone other than a tekmar Representative, including an inquiry from Purchaser (if not a tekmar Representative) or Purchaser's customers, regarding a potential warranty claim, tekmar's sole obligation shall be to provide the address and other contact information regarding the appropriate Representative.



tekmar Control Systems Ltd., Canada
tekmar Control Systems, Inc., U.S.A.
Head Office: 5100 Silver Star Road
Vernon, B.C. Canada V1B 3K4
(250) 545-7749 Fax. (250) 545-0650
Web Site: www.tekmarcontrols.com

Product design, software and literature
are Copyright © 2011 by:
tekmar Control Systems Ltd. and tekmar
Control Systems, Inc.