



1 Information Brochure
Choose controls to match application

2 Application Brochure
Design your mechanical applications

3 Rough In Wiring
Rough-in wiring instructions

4 Wiring Brochure
Wiring and installation of specific control

5 Data Brochure
Control settings and sequence of operation

6 Job Record
Record settings & wiring details for future reference

Overview

The following brochure describes how to wire the tekmarNet®4 (tN4) thermostat 538. The 538 has an output for one stage of heat, and an auxiliary sensor input for an optional floor or outdoor sensor.

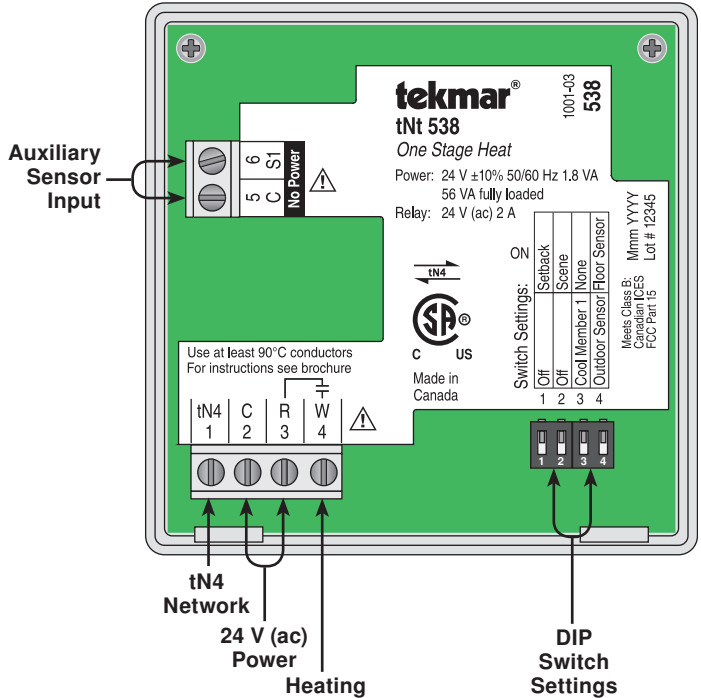

Table of Contents

- Definitions 2
- Rough-In Wiring 2
- Remove the Wiring Cover 3
- Mounting the Thermostat 4
- Wiring Symbols 5
- Electrical Drawings 5
- Wiring the Thermostat..... 8
- Troubleshooting the Wiring 10
- Testing the Wiring 10
- Technical Data 12

Definitions

The following defined terms and symbols are used throughout this manual to bring attention to the presence of hazards of various risk levels, or to important information concerning the life of the product.



– Caution: Refer to accompanying documents.



– Caution: Refer to accompanying documents.

**INSTALLATION
CATEGORY II**

– Local level appliances.

Caution

Improper installation and operation of this control could result in damage to the equipment and possibly even personal injury or death. It is your responsibility to ensure that this control is safely installed according to all applicable codes and standards. This electronic control is not intended for uses as a primary limit control. Other controls that are intended and certified as safety limits must be placed into the control circuit. Do not attempt to service the control. Refer to qualified personnel for servicing. There are no user serviceable parts. Attempting to do so voids warranty and could result in damage to the equipment and possibly even personal injury or death.

Rough-In Wiring

Choose the placement of the thermostats early in the construction process to enable proper wiring during rough-in.

Consider the following:

- Interior Wall.
- Keep dry. Avoid potential leakage onto the control.
- Relative Humidity \leq 92% to 104°F (40°C), and 50% above 104°F (40°C). Non-condensing environment.
- No exposure to extreme temperatures beyond 36-122°F (2-50°C).
- No draft, direct sun, or other cause for inaccurate temperature readings.
- Away from equipment, appliances, or other sources of electrical interference.
- Easy access for wiring, viewing, and adjusting the display screen.
- Approximately 5 ft. (1.5 m) off the finished floor.

Use standard 18 AWG wire for the thermostat power, stages, tN4 and sensor connections.

Refer to the diagram below to determine the number of conductors to run from each piece of equipment to the thermostat location.

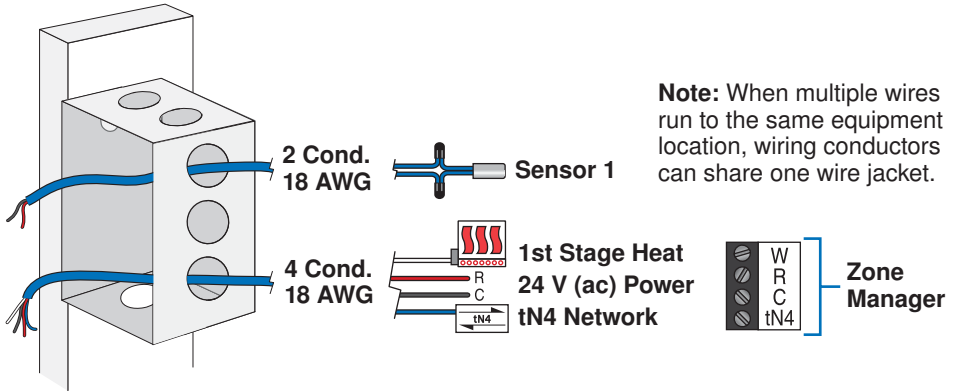

Remove the Wiring Cover

To remove the wiring cover:

- Place a small slot screwdriver or similar tool into the slot located on the top of the thermostat.
- While pushing against the plastic tab, pull the top of the front cover so that it pivots around the bottom edge of the thermostat's base.



Mounting the Thermostat

If a single gang switch box is used, an Adaptor Plate 007 is required to mount the thermostat to the box.

- Fasten the base of the thermostat to the adaptor plate.
- Feed the wiring through the openings in the back of the adaptor plate and thermostat.
- Use the upper and lower screw holes to fasten the adaptor plate to the box.

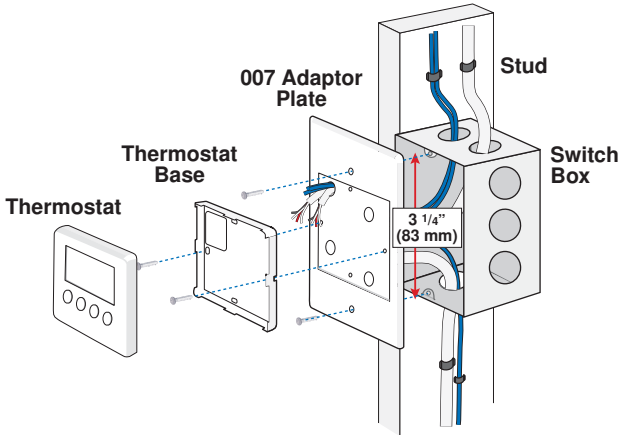

Mounted on switch box

OR



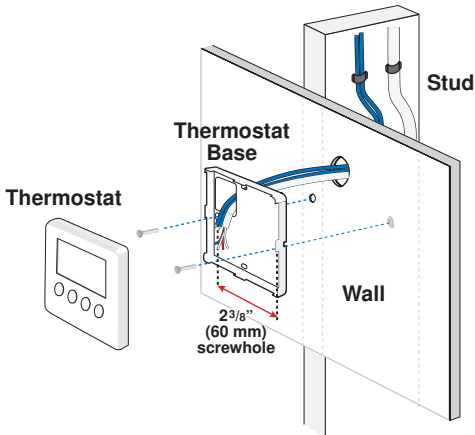

If a switch box was not used, mount the thermostat directly to the wall.

- Feed the wiring through the openings in the back of the thermostat.
- Use screws in the screw holes to fasten the thermostat to the wall. At least one of the screws should enter a wall stud or similar rigid material.



Mounted on wallboard

Wiring Symbols

	Dry contact switch. Operates a device.
	Powered switch. 24 V (ac), switched output to valve, pump relay etc.
	Do not apply power to these terminals. Serious control damage will result.
	tekmarNet®4

Electrical Drawings

The electrical drawing examples on the following pages show the 538 in common applications. Choose the drawing that most accurately depicts the components in your system and use that drawing as a guide to aid in wiring your system.

These are only concept drawings, not engineered drawings. They are not intended to describe a complete system nor any particular system. It is up to the system designer to determine the necessary components for and configuration of the particular system being designed including additional equipment isolation relays (for loads greater than the controls specified output ratings) and any safety devices which in the judgement of the designer are appropriate in order to properly size, configure and design that system and to ensure compliance with building and safety code requirements.

Description:

538 operates a hydronic heating system zone.

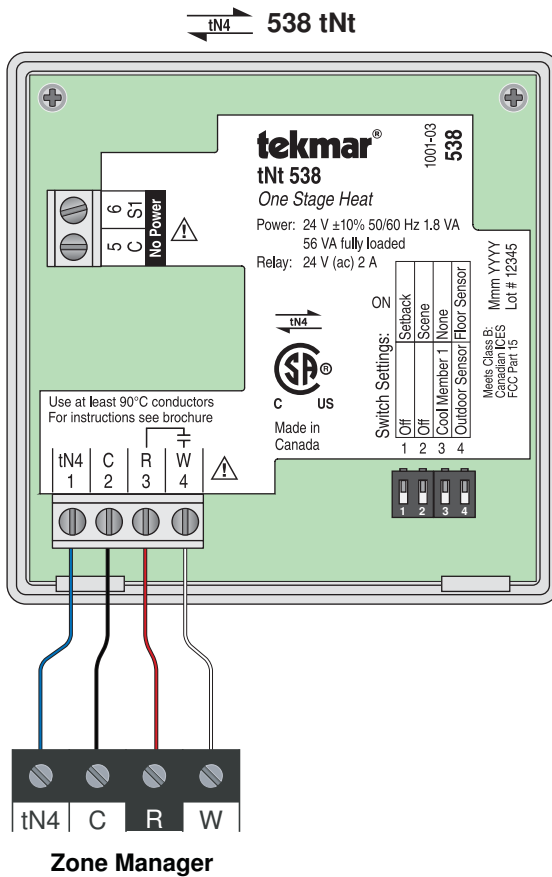
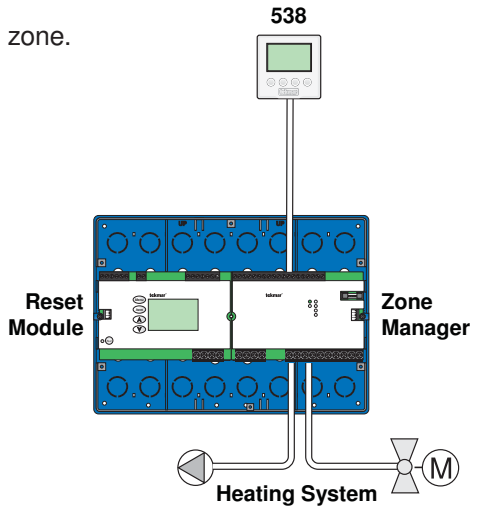

Description:

538 operates a hydronic heating system zone with an auxiliary slab sensor or outdoor sensor.

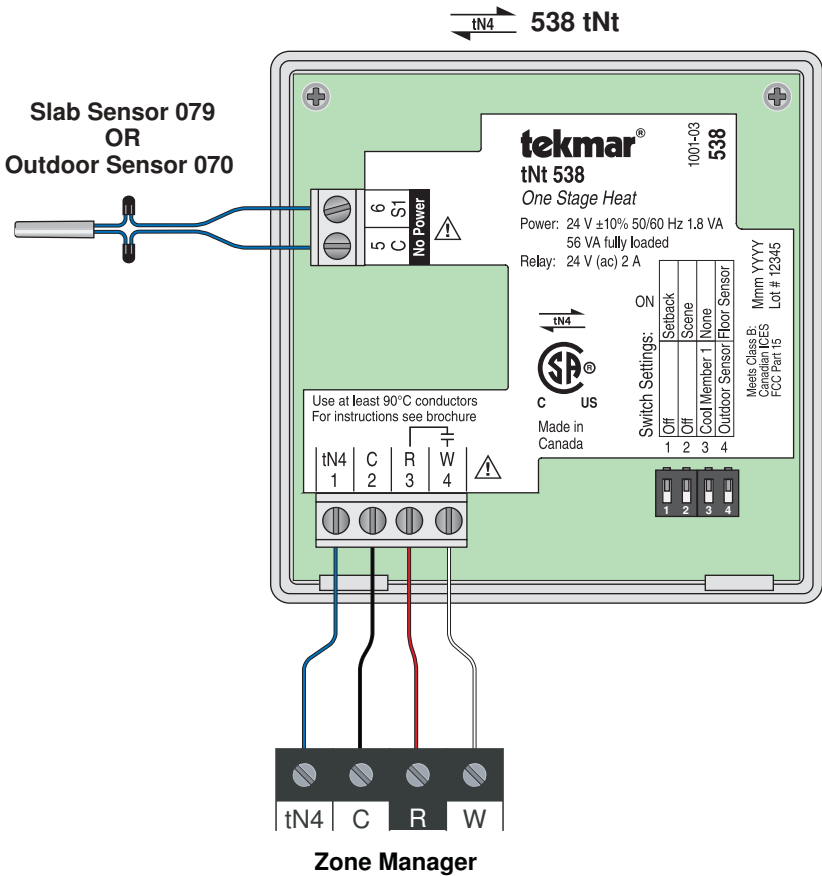
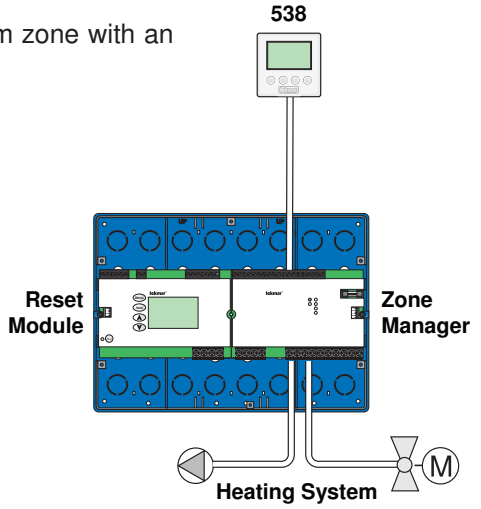

Wiring the Thermostat:

Power (24 V (ac))

Terminals 2, 3

Terminals R and C provide 24 V (ac) power.

If a Zone Manager is used:

- Connect C on the thermostat to C on the proper zone of the Zone Manager.
- Connect R on the thermostat to R on the proper zone of the Zone Manager.

If a 24 V (ac) transformer is used:

- Connect C on the thermostat to C on the transformer.
- Connect R on the thermostat to R on the transformer.

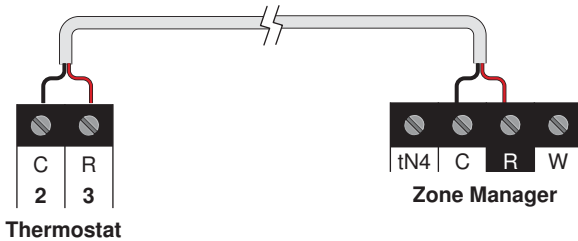

tN4 Communication

Terminals 1, 2

Terminals tN4 and C provide tN4 communication.

If a Zone Manager is used:

- Connect tN4 on the thermostat to tN4 on the proper zone of the Zone Manager used for the first stage of heat. The C terminal is already connected.

If a Zone Manager is not used:

- Connect tN4 on the thermostat to tN4 on another tN4 device on the same tN4 bus.
- Connect C on the thermostat to the C terminal on another tN4 device on the same tN4 bus.

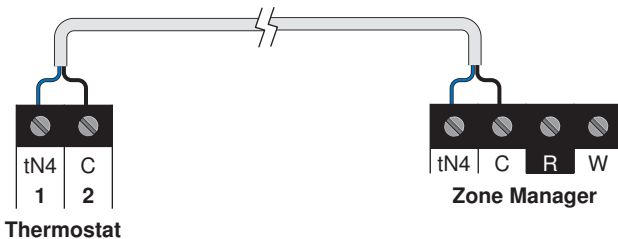

Note: This connection is polarity sensitive.

The W terminal is used to turn on the heating equipment.

The heating equipment must use the same power source as the R and C terminals.

If a Zone Manager is used:

- Connect W on the thermostat to W on the proper zone of the Zone Manager.

If a Zone Manager is not used:

- Connect W on the thermostat to the heating equipment (such as a furnace).

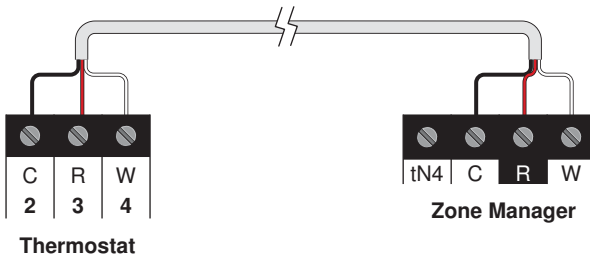

Auxiliary Sensor

Terminals 5, 6

The auxiliary sensor is connected to the thermostat on terminals C and S1.

Do not apply power to terminals 5, 6, permanent damage to the sensors and/or thermostat will result!

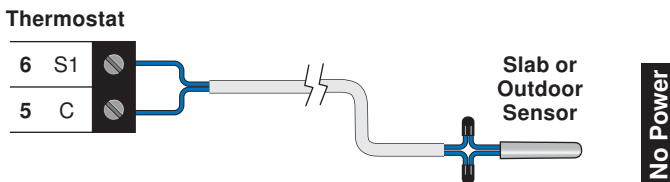

Troubleshooting the Wiring

General

The following tests are to be performed using standard testing practices and procedures and should only be carried out by properly trained and experienced persons.

A good quality electrical test meter, capable of reading from at least 0-300 V (ac), 0-2,000,000 Ohms, and testing for continuity is essential to properly test the wiring and sensors.

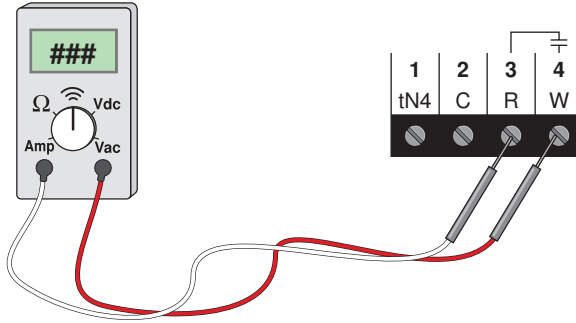

Testing the Wiring

Testing 24 V (ac) Power Supply

1. Remove the front cover from the thermostat.
2. Use an electrical test meter to measure (ac) voltage between the R and C terminals. The reading should be 24 V (ac) +/- 10%.
3. Install the front cover.

Testing the Relays

1. Remove the front cover from the thermostat.
2. Press Mode button until Mode is set to OFF.
3. Set electrical test meter to continuity.
4. Place probes between R (3) and W (4). There should be no continuity.
5. Press Mode button until Mode is set to HEAT.
6. Increase the Set Room temperature. The "H1" symbol should appear.
7. There should be continuity between the R (3) and W (4) terminals.

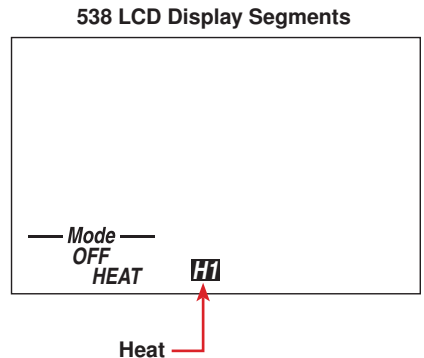

Testing the Sensor

To test the sensor, the actual temperature at the sensor location must be measured.

Use a good quality digital thermometer with a surface temperature probe for ease of use and accuracy. Where a digital thermometer is not available, place a spare sensor alongside the one to be tested and compare the readings.

1. Remove the front cover from the thermostat.
2. Disconnect the wires from the sensor that is to be tested.
3. Test the sensor's resistance according to the instructions in the sensor Data Brochure.
4. Reconnect the wires.
5. Install the front cover on the thermostat.

Testing the tN4 Buses

The \rightleftharpoons symbol is shown on the display when communication is present. If the thermostat is connected in a network and the communication is missing, there may be an open or short circuit on the tN4 and C bus wires.

1. Remove the front cover from the thermostat.
2. To test for short circuits:
 - Disconnect the tN4 bus wires on one end.
 - Install wire nuts on each wire to ensure the wire ends are not touching.
 - Disconnect the tN4 bus wires on the other end.
 - Measure for continuity using an electrical meter.
 - If continuity is present, there is a short circuit fault along the wires. It is recommended to replace the tN4 bus wires.
3. To test for open circuits:
 - Disconnect the tN4 bus wires on one end and connect them together.
 - Disconnect the tN4 bus wires on the other end.
 - Use an electrical meter to measure for continuity.
 - If there is no continuity, there is an open circuit fault along the wires. It is recommended to replace the tN4 bus wires.

Technical Data

tekmarNet® 4 Thermostat 538: *One Stage Heat*

Control	Microprocessor PID control; This is not a safety (limit) control
Packaged weight	0.8 lb. (380 g)
Enclosure	White PVC plastic
Dimensions	2-7/8" H x 2-7/8" W x 13/16" D (73 x 73 x 21 mm)
Approvals	CSA C US, CSA/UL 61010-1, meets Class B: ICES and FCC Part 15
Ambient conditions	Indoor use only, 36 to 122°F (2 to 50°C)
	RH max 92% to 104°F (40°C), and 50% above 104°F (40°C)
	Altitude <9840 feet (3000 m), Installation Category II, Pollution Degree 2
Power supply	24 V (ac) ± 10% 50/60 Hz, 1.8 VA Standby, 56 VA fully loaded, NEC / CEC Class 2
W Relay	24 V (ac) 2 A
Sensors:	NTC thermistor, 10 kΩ @ 77°F (25°C ± 0.2°C) β = 3892
– Included	None
– Optional	tekmar type # 071, 070, 072, 073, 076, 077, 078, 079, 083, 084

The installer must ensure that this control and its wiring are isolated and/or shielded from strong sources of electromagnetic noise. Conversely, this Class B digital apparatus complies with Part 15 of the FCC Rules and meets all requirements of the Canadian Interference-Causing Equipment Regulations. However, if this control does cause harmful interference to radio or television reception, which is determined by turning the control off and on, the user is encouraged to try to correct the interference by re-orientating or relocating the receiving antenna, relocating the receiver with respect to this control, and/or connecting the control to a different circuit from that to which the receiver is connected.

Cet appareil numérique de la classe B respecte toutes les exigences du Règlement sur le matériel brouilleur du Canada.



tekmar Control Systems Ltd., Canada
 tekmar Control Systems, Inc., U.S.A.
 Head Office: 5100 Silver Star Road
 Vernon, B.C. Canada V1B 3K4
 (250) 545-7749 Fax. (250) 545-0650
 Web Site: www.tekmarcontrols.com

Product design, software and literature
 are Copyright © 2008 by:
 tekmar Control Systems Ltd. and tekmar
 Control Systems, Inc.

