

This essay is presented in order to give the designer and installer a better understanding of the various control requirements of hydronic heating systems. Accurate and reliable control of a heating system is an important factor in finding the balance between energy efficiency, occupant comfort and equipment longevity. A fully integrated control system as illustrated in figure 1 has long been considered to be the best approach, and these systems are discussed in the following pages.

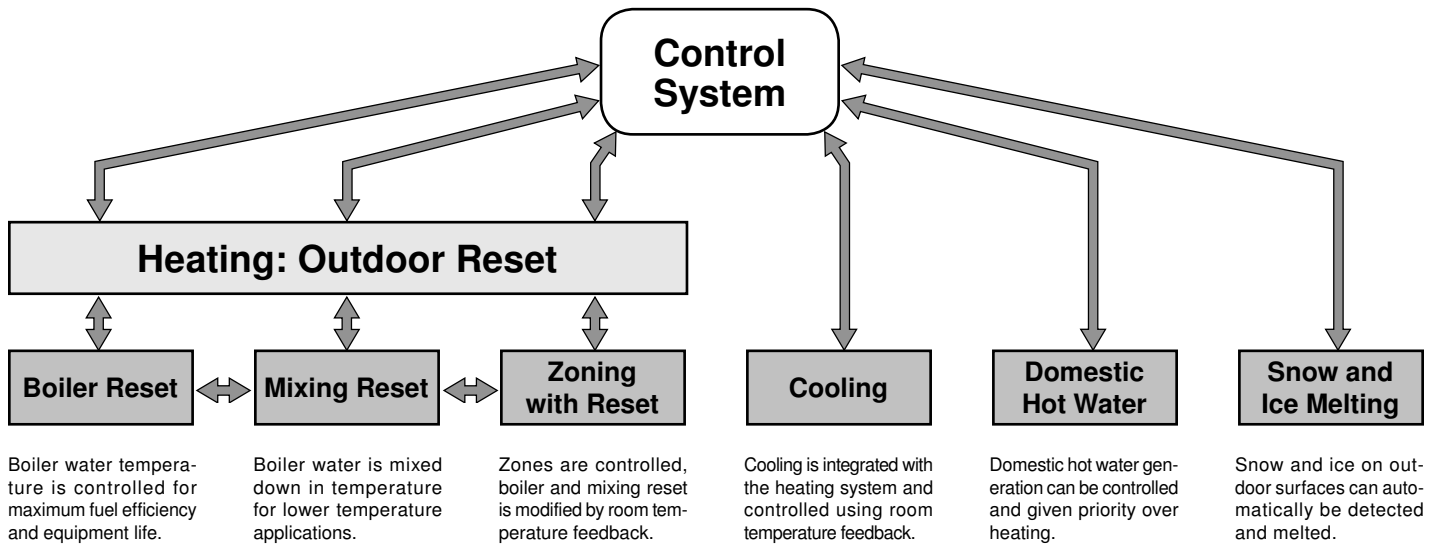

Fig. 1 A schematic illustration of a fully integrated control system

The ideal control should regulate a heating system to allow it to provide the exact amount of heat required to replace the heat lost from a building as illustrated in figure 2. When this is accomplished, the result is a steady and comfortable room temperature combined with efficient operation of the system.

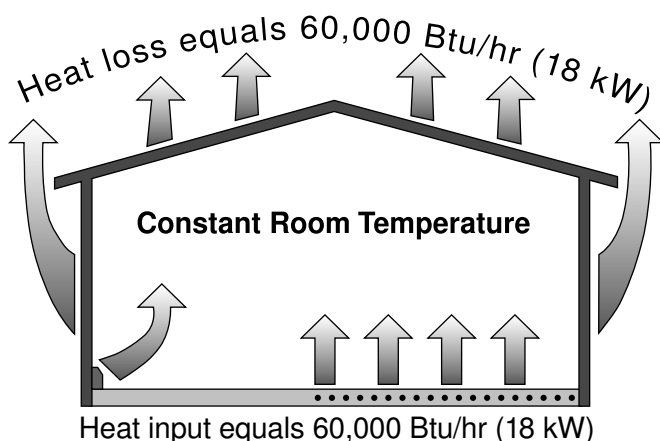

Fig. 2 Heat gain exactly balanced to heat loss

Unlike this example, the heat loss or gain of a building is a dynamic process, always changing. Some of the factors that complicate this process include; increases or decreases in outdoor air temperature, solar gain, wind (infiltration) losses and internal heat gain resulting from equipment, lights or people. When the outdoor temperature drops, causing a greater heat loss, we can increase either the flow rates or the water temperature of a hydronic heating system

to deliver more heat to the space. The following formula is used to examine heat transfer in such a system. Our objective is to explore the advantages and disadvantages of controlling the flow rate vs. the temperature of the water.

$$Q = \text{flow} \times \Delta T \times C$$

**Where:** Q = the heat transferred into or from the water, flow = the water flow rate,  $\Delta T$  = the temperature drop of the water, measured between the supply and return, and C = a constant that includes the specific heat and density of the water.

The following graphs were generated using this formula and clearly show the difference between the two control methods.

Figure 3 illustrates one of the disadvantages of designing a system that regulates heat output by controlling only the water flow rate. With a system designed for a 20° F (11° C) temperature drop, a 50% decrease in water flow only changes the overall heat output by 10%. The water flow must be reduced all the way down to about 10% of the designed rate in order to reduce the heat output by 50%. This uneven relationship between water flow rates and heat output requires a very difficult control action which is not very suitable for most heating systems.

Figure 4 illustrates how a much more linear relationship exists between differing water temperatures and heat output, allowing for very accurate and simple control actions well suited to heating system requirements. This relationship is constant through the full range of heating capacities. When the water flow is fixed at the designed flow rate, a 50% reduction in temperature difference

between the supply water and the room air results in a 50% reduction in the heat output. For example, with 70°F (21°C) room air and 190°F (88°C) supply water temperature, the temperature difference is 120°F (67°C). If the supply water temperature is reduced to 130°F (54°C), the temperature difference becomes 60°F (33°C), and we have effectively reduced the heat output of the system by 50%.

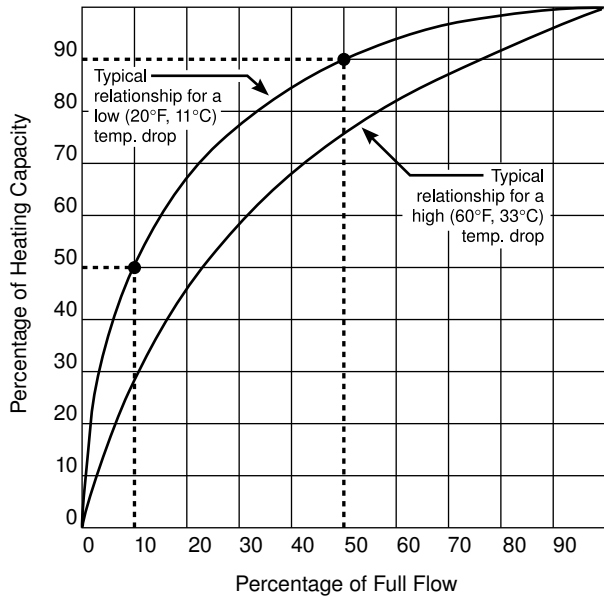

Fig. 3 Controlling heat output by changing water flow rates

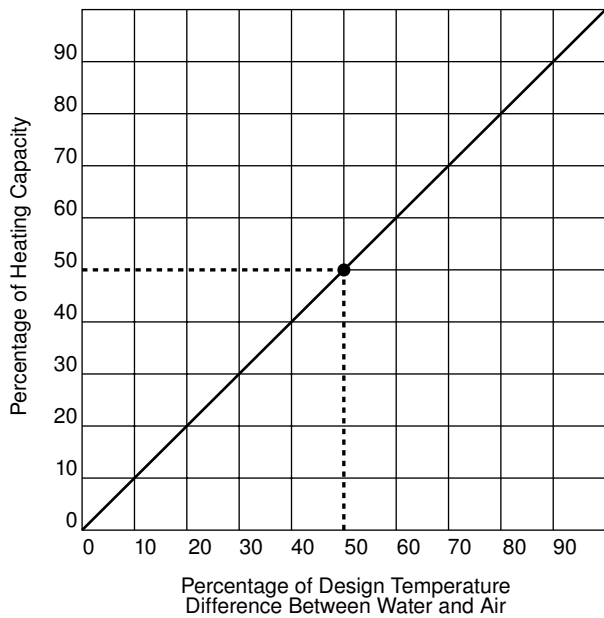

Fig. 4 Controlling heat output by changing water temperatures

**Outdoor Reset**

In choosing a heating system control strategy, we find outdoor temperature as the major variable factor affecting heat loss. Looking back to figure 2, it is clear that as it gets colder outside, the heat loss from the space increases and we need hotter water in our heating system to re-balance to this greater loss. This process is called Outdoor Reset (see figure 5), and assures that we keep the space at a constant comfort level even during quick or severe outdoor temperature swings. The two basic methods used to change the water temperature include cycling one or more boilers on or off or modulating their firing rates (boiler reset), and mixing hotter

system supply water with colder system return water (mixing reset). Mixing reset control uses 3 or 4-way mixing valves or a hot water injection system using fixed or variable speed pumping. A control that can't detect outdoor temperature changes responds only when the actual space temperature changes noticeably, causing uncomfortable indoor temperature droop or overshoot.

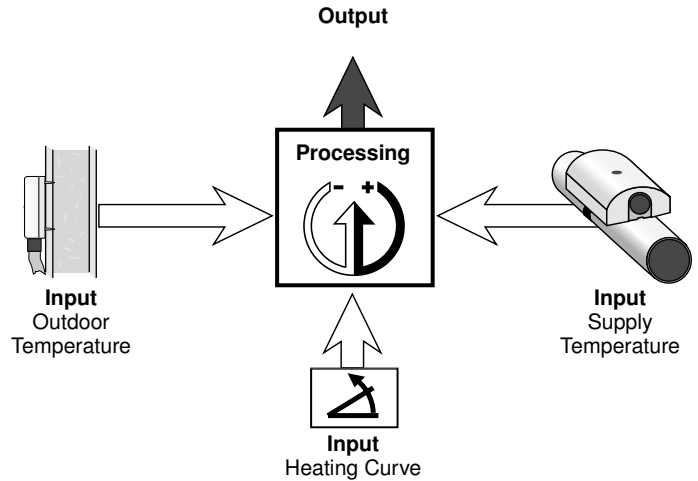

Fig. 5 Outdoor reset function

An electronic control calculates the desired temperature internally, based on a "heating curve". Referring to figure 5, we see that as the outdoor sensor measures a colder temperature, the control compares that reading with both the heating curve and the reading from the supply water temperature sensor. The control then generates an output signal to operate a boiler or mixing device, which increases the supply temperature. The correct heating curve is selected for each building by considering those factors that affect rates of heat gain vs. heat loss. The most important are the construction type, location and insulation levels of the building, along with the heating system design.

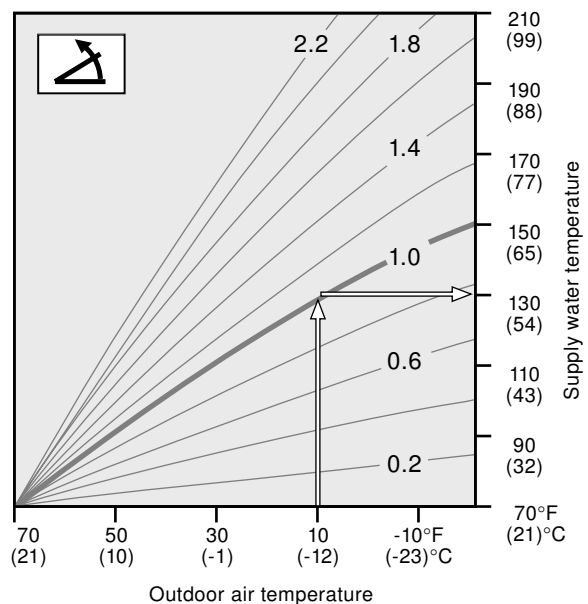

Fig. 6 Typical heating curve

The illustration of a typical heating curve in figure 6 shows how the supply water temperatures relate to the outdoor temperatures. The number shown on each curve indicates the ratio of supply water temperature increase to outdoor air temperature decrease.

If a heating curve of 1.4 is selected, the control will increase the supply water temperature by 1.4° for every 1° drop in outdoor temperature. In the example in figure 6, the heating curve selected is 1.0. When the outdoor temperature is 10°F (-12°C), the control will increase the supply water temperature to 130°F (54°C). Using the same heating curve, you can see that if the outdoor temperature is 50°F (10°C), the supply water will be 90°F (32°C).

### Boiler Reset

Figure 7 shows the boiler reset function with a hydronic heating system using constant water circulation for precise control action. With the correct heating curve selected, the heat source is controlled to maintain the supply water at the lowest practical temperature required to supply sufficient heat to the building. The temperature is raised only when needed in the colder weather; outdoor reset reduces energy usage by reducing overheating and standby losses, and saves wear and tear on the heating equipment by lowering the typical operating temperature.

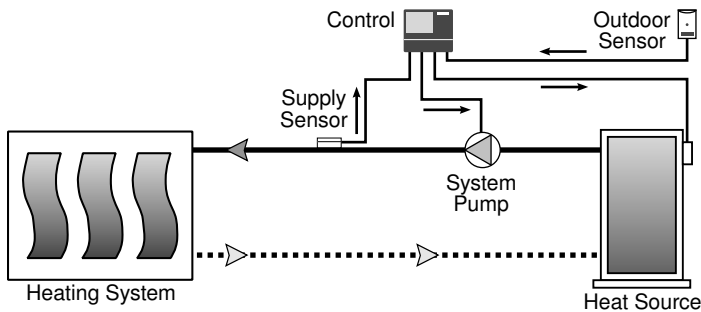

Fig. 7 Boiler reset function

One important consideration in the selection of a boiler heating curve is the minimum water temperature that the heat source can safely operate at. A condensing type boiler, electric boiler or heat pump can be operated at very low supply water temperatures, but conventional oil or gas fired boilers usually require a minimum supply water temperature of at least 130°F (54°C) in order to prevent condensation of the flue gases and subsequent corrosion and blockage of the boiler heat exchanger and the chimney.

### Mixing Reset

Because of boiler minimum temperature requirements, conventional oil or gas fired boilers often require mixing reset. At warmer outdoor temperatures or with hydronic radiant floor heating systems, the system supply water temperature must be reset lower than 130°F (54°C). The best way to do this while protecting the boiler, is to mix the cooler system return water with the boiler supply water. This method allows low temperature water to be supplied to the heating system and hotter water to circulate through the boiler, preventing flue gas condensation. This mixing process can be controlled by using a 3 or 4-way mixing valve, a hot water injection system using a valve or fixed speed pump, or a hot water injection system using variable speed pumping.

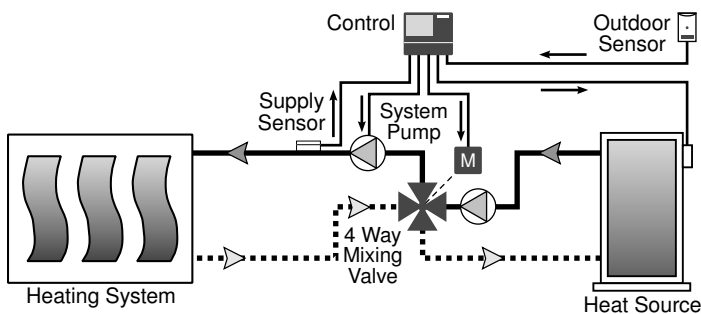

Fig. 8 Mixing reset function with 4-way mixing valve

Figure 8 shows a 4-way motorized mixing valve located between the boiler and the heat distribution system. When the mixing valve is closed, the boiler and distribution system are separated from each other and no heat is transferred to the system. The system water is continually circulated for even heating. The boiler water is maintained at the boiler minimum temperature and flows through the boiler by convection or pumping. When the heating system requires more heat, the control opens the valve, heating up the cooler system water by adding hot boiler water.

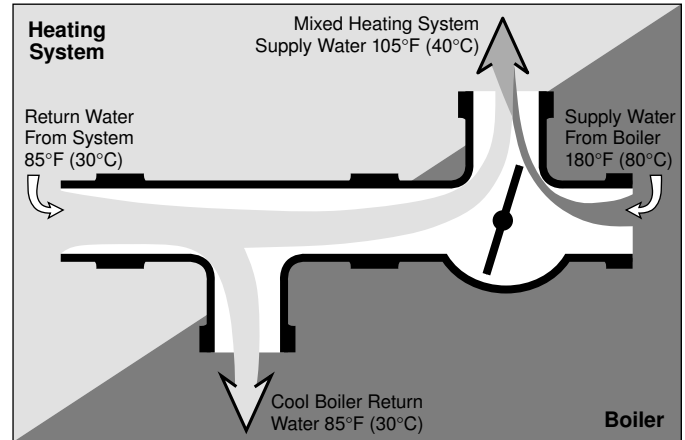

Fig. 9 3-way mixing valve

Figures 9 and 10 illustrate the differences between the operation of 3-way and 4-way mixing valves and why a 4-way valve is preferred in applications where condensation of boiler flue products or low boiler water flow rates can be a problem.

Figure 9 shows that when a 3-way valve is in the fully closed position, there is no water flow through the boiler. Also, when the system requires heat and the valve does open, the return water into the boiler is untempered and can be too cool, causing low enough boiler temperatures to result in flue gas condensation.

Figure 10 shows how using a 4-way mixing valve eliminates these problems. When using a 4-way valve, full flow through the boiler is assured regardless of valve position, and the return water to the boiler is warmed by whatever volume of boiler water has not been diverted into the heating system.

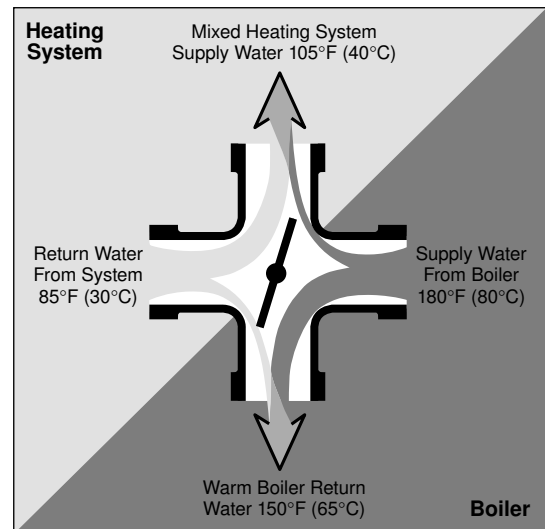

Fig. 10 4-way mixing valve

Figure 11 illustrates the use of a hot water injection system with mixing reset function. If the system supply water drops below the desired temperature calculated by the reset control, the two-way zone valve is cycled on to inject heat into the continuously circulating system loop until the correct temperature is restored.

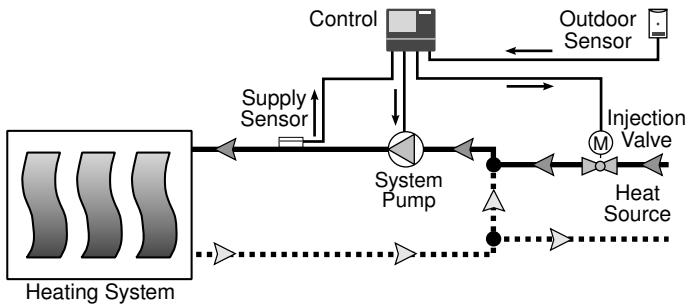

Fig. 11 **Mixing reset with valve injection**

When an injection system is used, it is very important to maintain a continuous water flow past the supply sensor so that the reset control will be able to read the correct temperature and the pump will keep the water in the system well mixed at all times. If the system is zoned, the control action can become erratic when all of the zones close and the water flow stops. For this reason the injection system should only be used in single zone systems, or a bypass loop should be installed between the system pump and the zones to assure constant circulation.

In figure 12, we show an injection system using a pump rather than a two-way valve. For large volume/input systems, a single speed pump can be used and controlled much as you would control an injection valve, with a simple on/off signal. Because a pump injects much more heat than a similar sized valve, smaller systems are subject to too much variation in water temperature to effectively use a single speed on/off injection pump, and for this reason a variable speed pump is recommended. With a variable speed pump, the injection of hot water into the heating system loop is continuous and the volume of water is varied by speeding up (more heat) or slowing down (less heat) the pump rotation. This way of mixing reset can be used for a number of applications on systems with a wide variety of flow rates.

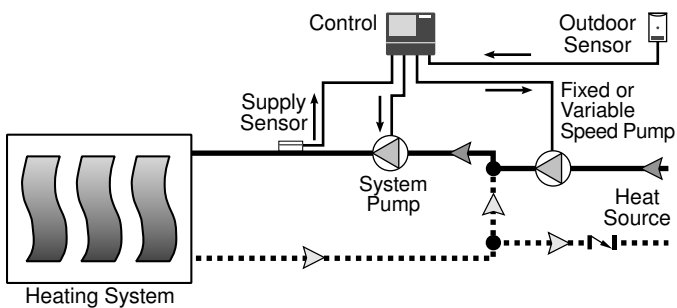

Fig. 12 **Mixing reset with pump injection**

Both mixing reset and boiler rest are often combined in commercial applications. Boiler stand-by heat losses are minimized and the boiler is kept hot enough to prevent condensation of combustion gases by the boiler reset control. The mixing reset control, at the same time, controls the heating system to a full range of water temperature modulation in order to maintain efficiency and fine temperature control. A combination of boiler and mixing reset controls can also be used in buildings with systems designed for different water temperatures operating from a common heat source. Hydronic radiant floor (HRF) systems, for example, usually require maximum supply temperatures of between 105°F and 130°F (40°C to 54°C), with average required water temperatures often lower

than 85°F (30°C). With mixing reset, these low temperatures can be supplied to the HRF system while at the same time allowing the boiler to supply areas of the building that have fan coils or convectors with water temperatures all the way up to the boiler high limit settings.

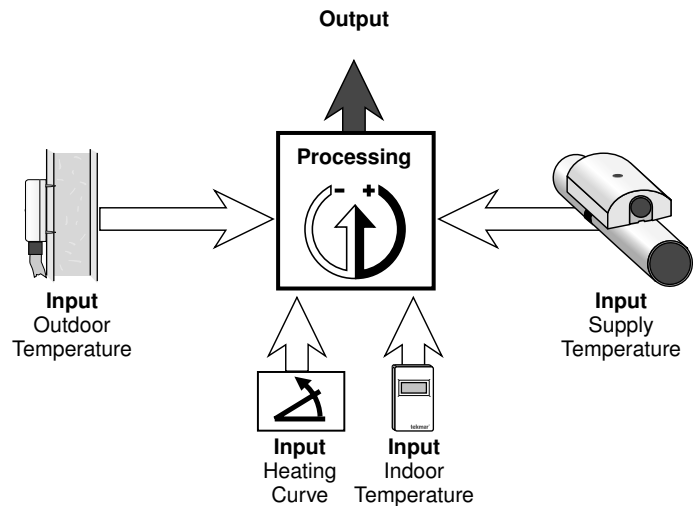

Fig. 13 **Zoning; room temperature feedback with outdoor reset**

### Zoning with reset

Although outdoor air temperature has the greatest effect on the heating load of a building, once the water temperature in the heating system has been reset to counter the building envelope heat loss, other factors affecting the temperature in the space must be considered. Additional heat gains or losses from sources such as appliances, solar radiation, people, wind infiltration, etc., should be accounted for in controlling space temperatures.

Figure 13 shows the elements normally used in a control system with outdoor reset and zone control. In reset with zoning systems, sensors are used to read the indoor temperature in one or more rooms within the building. This information is combined with the supply and outdoor temperature readings to be processed by the control into a desired supply water temperature that is shifted higher or lower than it would be when determined by the heating curve calculation alone.

As an example – under normal circumstances, if the outdoor temperature was 10°F (-12°C), and the selected heating curve was 1.0 (see figure 14), the heating curve calculations would require a supply water temperature of 130°F (54°C). A room with a larger than normal heat loss however, (i.e. large window surface and no solar gain), will soon become colder than the other rooms in the building. Supplying space temperature feedback from that room to the control will shift the heating curve up, and consequently raise the supply water temperature. This increase will offset the greater heat loss, and as the room warms up, the curve gradually shifts back down to a lower level to prevent overheating. In this type of system, the zone with the highest heat demand elevates the system supply temperature higher than necessary for the other zones. To prevent overheating in the other zones, room temperature feedback is used to operate a valve or pump, cutting off the water flow when necessary. When the water temperature is reset close to the desired operating temperature for the system, flow interruption in the 10% to 20% range is typical, and is quite effective in providing the fine control needed for individual room temperature comfort.

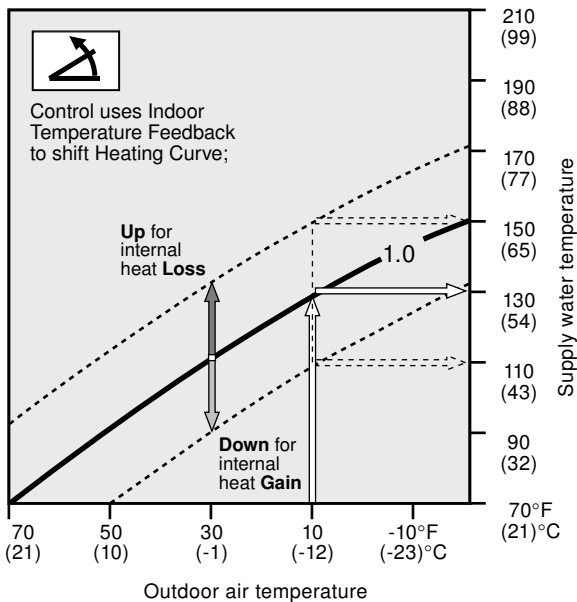

Fig.14 Zoning; room temperature feedback with outdoor reset

### Additional Control Requirements

In addition to space heating control of hydronic systems, there are other commonly used functions that should be integrated into the overall control strategy.

### Cooling

Heating and cooling systems are becoming more complex and should be controlled using an integrated control method. Currently, many cooling and heating systems have completely separate control systems without any connection between the two. The most common problem occurs when both systems operate at the same time as a result of incorrect settings for switch-over from one to the other. Integrated control of both systems prevents this and many other related problems, giving the occupants greater comfort and increasing energy savings.

### Domestic Hot Water (DHW)

Three methods of generating DHW are commonly used today.

#### Stand-alone heaters

Stand-alone heaters are used in a variety of applications because of their versatility and low initial cost. The most common type of stand-alone heater is the small volume storage water heater. Most storage water heaters have low inputs, lengthy recovery times and therefore relatively high storage capacities. They are self contained units with dedicated thermostatic control devices and heating elements or burners. Heat losses are reduced as much as possible by insulating the tank to minimize jacket losses and installing flue dampers, where permissible, to eliminate standby flue losses. For larger volume applications, many manufacturers have made specially designed high input boilers for the exclusive production of DHW. Controls for these boilers are usually stand-alone, dedicated systems that can vary from simple on/off controls when used with storage tank applications, to modulating controls used in systems with wide variable flow rates.

#### Tankless coils

Figure 15 shows a heating system with a tankless coil heat exchanger. The boiler control must have a minimum temperature setting to maintain boiler temperatures at or above the desired DHW temperature, and when the outdoor temperature gets cold enough, the control should operate a reset function in order to provide the

hotter water needed to heat the building. When a system has an operating boiler kept at high temperatures year-round for other than space heating reasons, this is a good way to heat DHW. The main disadvantage to this system is that the heating boiler must be a high mass boiler, kept at higher than the DHW required temperature even in the summer months when no heat is wanted. The result is overheating and inefficient operation.

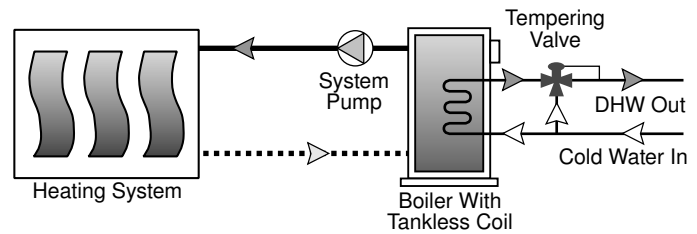

Fig. 15 DHW from a tankless coil

#### Storage tank heat exchangers

Figures 16 and 17 illustrate a flexible and economical solution to DHW generation when using hydronic heating systems. A large surface area heat exchange coil is built into an insulated storage tank to create the modern storage tank heat exchanger. In standard applications, the boiler can be operated on a DHW priority basis using a simple on/off aquastat, or can be operated by a more sophisticated control which integrates the generation of the DHW with the heating/cooling system needs.

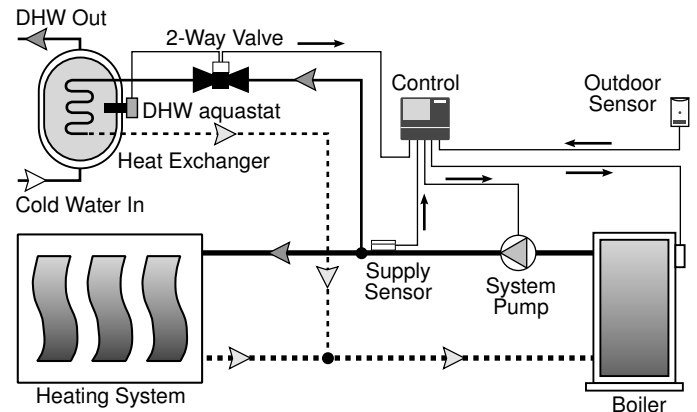

Fig. 16 DHW from a heat exchanger using a 2-way valve

A boiler control that switches automatically from heating mode to DHW mode, when signaled by a 2-way valve, is shown in figure 16. When the DHW aquastat opens the valve, a switch in the valve sends the control a signal which tells it to operate in a setpoint mode. In setpoint mode, the control will operate the pump and bring the heat exchanger up to the required temperature. When the DHW aquastat is satisfied, the valve is closed, and the valve switch sends a signal to the control to return to heating mode.

A different approach to operating a boiler in heating mode and DHW mode is illustrated in figure 17. This is a more sophisticated system, and gives a true integration of the two separate functions. The control has sensors to measure both the heating system supply water temperature, and the DHW temperature. The boiler normally operates in the heating mode, but when the DHW sensor temperature is too low, the control automatically switches off the system pump, switches on the DHW pump, and operates the boiler at a setpoint temperature high enough to generate the required DHW. A big advantage here, is that priorities and setback schedules can be selected to operate both functions as required.

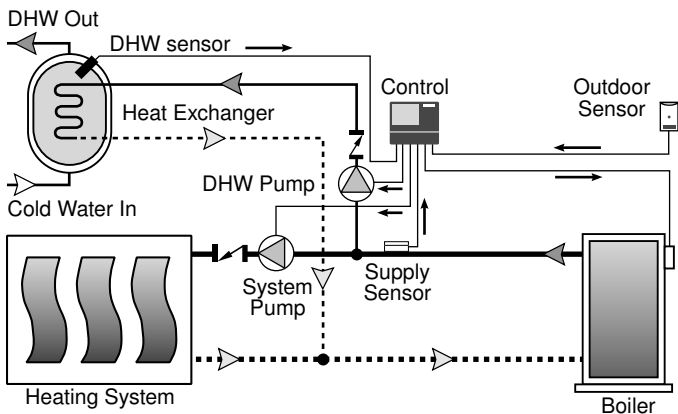

Fig. 17 **DHW from a heat exchanger using pumps with an integrated control system**

Using a storage tank heat exchanger can be the most efficient way to generate DHW. Most fuel burning boilers have better combustion efficiencies than stand-alone water heaters, and since these tanks are usually very well insulated and have no chimney flue, the standby losses are minimal. Most heating boilers have relatively high inputs, allowing faster recovery times and reducing the volume of hot water storage needed. Control accuracy is usually improved when using an integrated control, since DHW temperatures are measured and controlled by a better quality device than would normally be used for DHW only applications.

#### Other Water Heating

Secondary heat exchangers similar in operation to the heat exchanger/storage tank are also used for other water heating tasks such as heating a pool or spa. Their use is particularly valuable when used in those applications where the water can be corrosive to ordinary boilers and components. As with DHW generation, control of these auxiliary functions can also be integrated with the heating system control and each function can be given applicable priorities based on overall system needs.

#### Snow/Ice Melting

Figure 18 shows a hydronic snow/ice melting system using a dedicated boiler and a 4-way mixing valve. Because of the increased labour costs and the inconvenience of snow removal, and as a result of increasing insurance claims due to accidents, snow/ice melting systems are gaining in popularity. Positive developments with plastic tubing and heat exchanger technology have allowed for much greater equipment reliability and simpler heat distribution system installations.

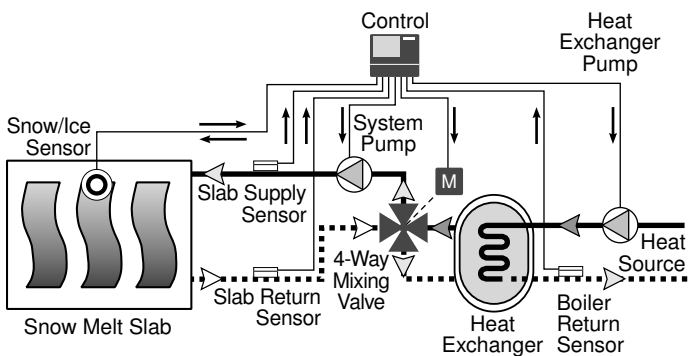

Fig. 18 **Hydronic snow/ice melting system**

Control of snow/ice melting systems can vary greatly in complexity depending on the equipment used and the application chosen. The most basic systems use a simple on/off signal to activate

a dedicated heat source and either melt snow or ice whenever present or maintain a fixed slab temperature above the freezing point. When a heat source such as a gas or oil fired boiler is used, the boiler must be protected from cold slab return water to prevent flue gas condensation and subsequent boiler damage. When a large input heat source is used, the slab must be protected from thermal shock by limiting the amount of heat delivered, relative to the slab temperature. For fast response to snow/ice conditions, it is often necessary to maintain the slab at an elevated "idle" temperature, somewhere just below or above freezing, and activate the heat source to deliver more heat when snow/ice is present. For complete, reliable control, an automatic snow/ice detection device is often used to signal the control to switch into operating mode the instant that snow or ice is found to be present.

#### Control System and Heating System Design

To properly utilize an integrated control strategy, it is very important for the designer to be aware of the available options before starting to put a system together. A good understanding of system design is essential. Although every heating system has some unique requirements, there are enough common factors involved to allow the designer to apply these basic "Golden Rules" of system design.

- **Complete an accurate heat loss calculation**

Before deciding on the size of the heating equipment required, a heat-loss calculation for the building must be done. Avoid those old "rule of thumb" heat loss calculations, as they usually date back to a time when buildings had no insulation, radiators were all high temperature and boilers were very inefficient. Detailed heat loss calculations must be done as accurately as possible, using the most up-to-date heat loss programs or procedures available. A correctly sized system is essential for maximum efficiency.

- **Do not oversize equipment**

Most common mistakes found in system design today usually stem from the old attitude "bigger is better". Because many installers and designers neglect heat loss or water flow calculations, they are unsure of the correct sizing for equipment and compensate by oversizing "just in case". Oversized boilers will short cycle, have a tendency to go off on high limit settings and create large temperature swings in the system supply water temperature all of which reduce efficiency. Oversized pumps are usually prone to cavitation, creating excess noise and wear in the piping system, boiler and pump itself.

- **Properly match all system components**

The designer must be familiar enough with the operation of the various system components and controls to prevent misapplication. Correct control strategies must be chosen for each system requirement and properly matching components selected to do the job. Consider each application carefully rather than selecting a particular component on every job just because "you've always had good luck with it." Whenever possible, all system components and controls should be integrated to increase overall control accuracy and optimize system efficiency.

- **Install an outdoor reset control**

Some method of automatic boiler and/or supply water temperature outdoor reset should be used with any hydronic heating system. Lowering these water temperatures whenever the heat loss of a space decreases due to warming outdoor temperatures, prevents unnecessary heat loss, occupant discomfort and equipment wear, saving energy.

• **Provide continuous water circulation with heat demand**

Continuous circulation in the primary heating loop, combined with outdoor reset has many advantages.

- There is a more even heat distribution throughout the entire system causing less draft and providing greater occupant comfort.
- The system supply temperature can be set lower, increasing boiler efficiencies and reducing distribution piping heat losses.
- Large temperature swings in the system supply water temperature are avoided, reducing stress on the system components, and thermal expansion/contraction noise in the distribution piping.
- Control action is improved with continuous flow past the sensor since the control doesn't have to compensate for large temperature swings and is continually monitoring the correct system supply temperature at all times through the heating cycle.

**Important — If reset controls are used in a multiple zone system where continuous flow is interrupted due to the shutting off of the zone pumps or valves:**

- **A bypass loop should be installed between the system pump and zones to maintain constant flow past the sensor.**

**OR**

- **A signal should be sent to the reset control when the zones are closed or the system pump is turned off in order to let the control ignore the system supply water temperature readings and go into a shut-down condition.**

• **Provide temperature protection for equipment**

Understand the operating limitations of system components and provide adequate control protection.

Controls can provide protection against overheating at different levels. Approved safety limit devices must be installed where specified by either legal code or equipment manufacturer's requirements, but operational limits can be selected as control options to protect sensitive system components. (e.g. plastic pipe, slab protection, etc.)

Control limits can also be set to provide protection for components that will be damaged from temperatures that are too cold. (boiler return water protection, freeze protection, etc.)

• **Provide zones based on differing heat gain/losses**

Zoning a building or space saves energy and increases comfort levels when zones are chosen correctly. In many cases zones are incorrectly chosen on a room by room basis without any consideration of heat gain or loss differences. For example — If there are a number of rooms on the north side of a building that all have identical heat losses without significant internal gains, there is no point in splitting them up into a series of small zones. If one of these rooms happens to have a large internal gain however, that room should be controlled as a separate zone.

It is important to identify those areas of a building that have common heat losses or gains and provide zone control accordingly. A zone with an imbalanced heat loss will over or under heat in one area of the zone as the control system tries to maintain comfort levels in the other area.

Refer to Essay E 001

**High Quality Controls = Energy Savings and More Comfort**

High quality controls, combined with the correct control strategy, can result in higher levels of occupant comfort and significant energy savings. Using less fuel is good for the environment, and spending less money is good for the pocketbook.

- Proper control of a hydronic heating system results in even temperatures and more comfort for building occupants. When occupants are comfortable, they are less likely to tamper with thermostat settings and overheat occupied spaces.

❖ *High Quality = Energy Savings and More Comfort*

- Outdoor reset keeps the supply water temperature as low as the heating demand requires. This prevents overheating and minimizes heat losses from the distribution piping and the heat source.

❖ *High Quality = Energy Savings and More Comfort*

- Outdoor reset of the supply water temperature allows flow controls such as zone or radiator valves to be in an open, controlling position, allowing better circulation of the water, more even temperatures and less noise.

❖ *High Quality = Energy Savings and More Comfort*

- Outdoor reset of the supply water temperature results in less wear and tear, fewer breakdowns and longer component life, since heating equipment doesn't have to work as hard.

❖ *High Quality = Energy Savings*

- With outdoor reset, if a window or door is left open, the heating system will only be able to supply a limited amount of heat in compensation before the room cools off. This will cause the occupants to close the opening to the outdoors, and will prevent the rest of the building from becoming overheated.

❖ *High Quality = Energy Savings*

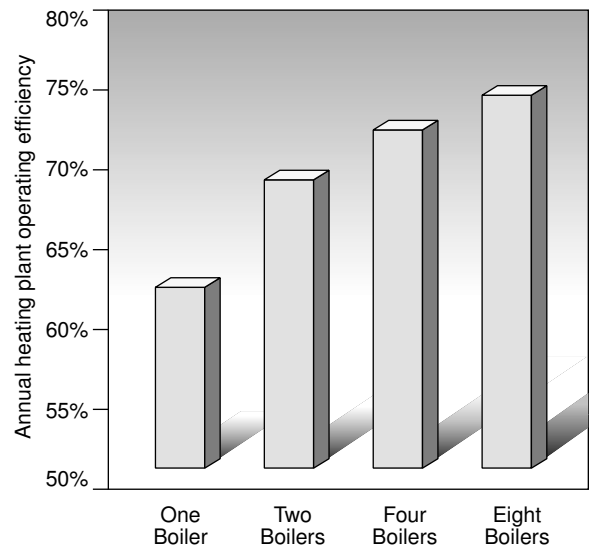

Fig. 19 Energy savings with boiler staging

- Boiler staging saves through reduced energy use. As we can see from figure 19, these savings can be quite significant when dealing with larger commercial applications using many stages.

❖ *High Quality = Energy Savings*

- If a building is zoned correctly, each zone can operate at it's required heat demand. The system will supply heat to those zones that need it and avoid overheating the whole building.

❖ *High Quality = Energy Savings and More Comfort*

## Tools and Resources

tekmar has developed technical support programs designed to assist installers, wholesalers and engineers in the use of tekmar controls. These programs combine the publication of technical information with progressive schooling in all aspects of our control system function and design and are constantly being updated to present the latest information available in the industry.

**The tekmar Application Drawings** (see partial example below) are designed to illustrate the typical control system applications likely to be encountered in the field and the tekmar control options available to deal with them. Every application has a mechanical drawing, an electrical wiring schematic, and detailed control specifications. Our application register A 000, is a quick and easy cross reference tool for anyone wishing to locate a specific application. Once a selection is made, the user can locate the drawings, literature and controls best suited for the application.

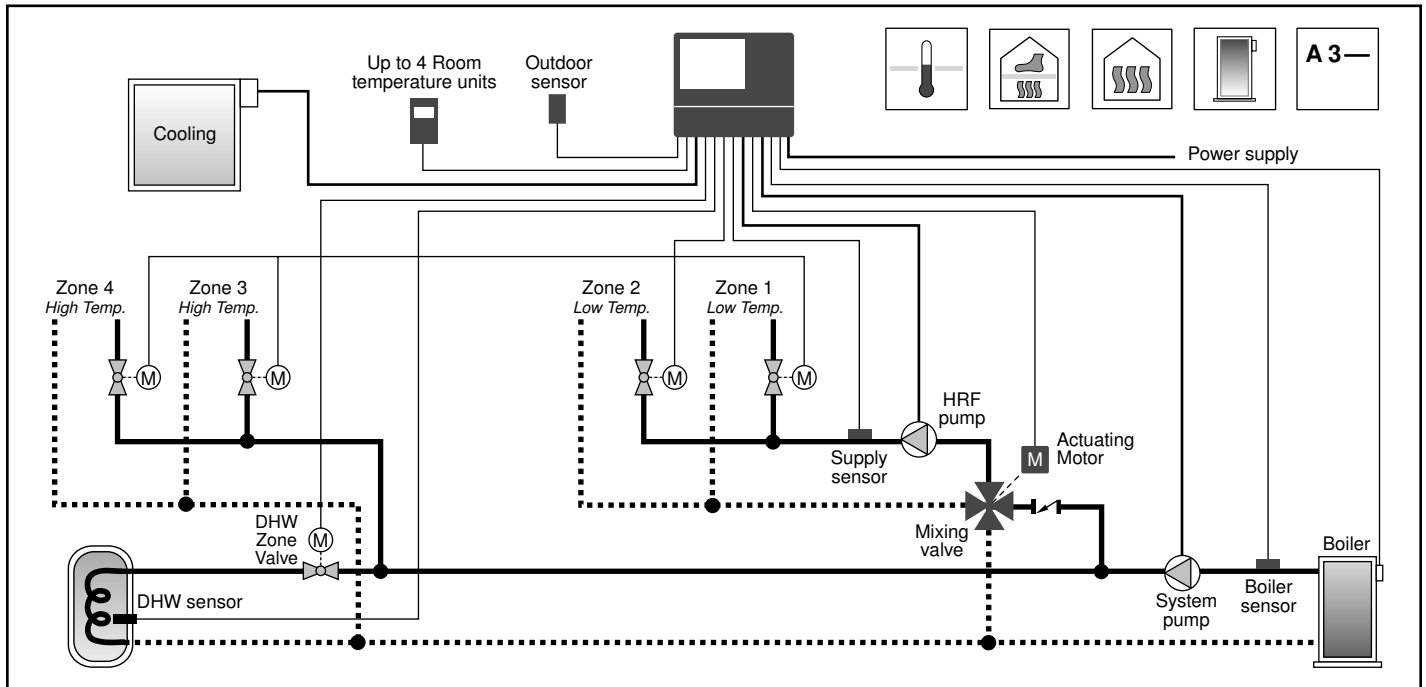

**The tekmar Essays** explore control theory and application and explain important control features, methods and strategies. We have made these essays available in order to help assist designers in attaining maximum energy savings, reliable operation of heating equipment and desired occupant comfort levels.

**tekmar Control Course and Control Schools** are presented on a regular basis across Canada and the USA by tekmar certified Control School Instructors. After attending a Course or School, the participant is encouraged to take a written examination relating to the material covered. tekmar Course and School certificates will be issued to those who successfully complete the examinations, and those certificate holders will receive special technical and marketing support from tekmar.

**The tekmar Control Course** is approximately 1/2 day in length and includes information on:

- the tekmar product line
- the tekmar technical support program
- control requirements for hydronic heating systems
- tekmar control and sensor installation and troubleshooting instructions

**The tekmar Control Schools** each cover a specific product group, and are approximately 1/2 day in length. The control groups covered include: setpoint controls, boiler controls, heating/HRF controls and snow melting controls. Each School includes information on control and system sequence of operation for various applications and gives detailed installation, setting and testing instructions. Additional schools will be available in the future. To obtain a tekmar School certificate, the participant must hold a tekmar Course certificate and successfully complete examinations in both the boiler controls and heating/HRF control groups.

**For more information**, please contact your tekmar agent or wholesaler.



tekmar Control Systems Ltd., Canada  
tekmar Control Systems, Inc., U.S.A.  
**Head Office: 5100 Silver Star Road**  
**Vernon, B.C. Canada V1B 3K4**  
**(250) 545-7749 Fax. (250) 545-0650**  
**Web Site: [www.tekmarcontrols.com](http://www.tekmarcontrols.com)**