



## Control Strategy

### ZONING OPERATION

In a multiple zone heating system, the zones may have different internal heat gains, heat losses or different temperature settings. Each zone must therefore have individual temperature control. For maximum comfort, the heat should be continuously supplied to the zone at the same rate the zone is losing heat. The most accurate method of accomplishing this is by outdoor reset; however, it is not normally economical to modulate the supply water temperature to every zone.

Outdoor reset can be combined with zoning for a more cost effective solution. Through indoor sensors, a zone control can provide indoor temperature feedback to the outdoor reset control. The outdoor reset control will then adjust the supply water temperature to satisfy the zone with the highest water temperature requirement. Heat to the remaining zones will be cycled on and off by the zone control using zone valves or pumps. Since the heat is cycled on and off, accurate PID control logic should be provided to maintain a stable indoor temperature.

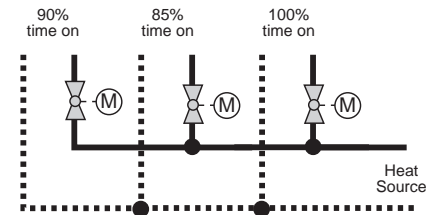

### PID Zoning Logic

#### Proportional (P)

In order to prevent indoor temperature swings, the heat supplied to each zone must be proportional to the heat required by the zone. Proportional control logic can be accomplished by pulse width modulation (PWM). A typical PWM system has a fixed operating cycle. During this operating cycle, the on time of the zone relay is varied based on the difference between the desired zone temperature and the actual zone temperature. As the zone temperature drops, the relay on time increases and as the zone temperature rises, the relay on time decreases.

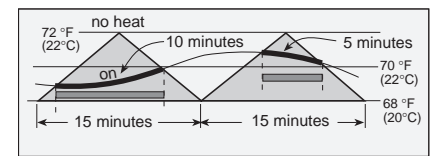

#### Integral (I)

Controls that are strictly proportional suffer from a problem of offset. The amount of heat supplied to the zone depends on how far the space temperature is below the desired setpoint. This implies that as the heating load increases, the average room temperature droops. On the coldest day of the year, the most heat is required and therefore the room temperature must be coldest.

In order to overcome this offset, integral control logic is used. Only digital controls can provide integral control logic due to the lengthy response time of buildings. Integral control logic is based on time. The longer the room temperature is below the desired setpoint, the more heat is supplied to the room. With integral control logic, full heat can be supplied to the room on the coldest day of the year without requiring that the room be cold.

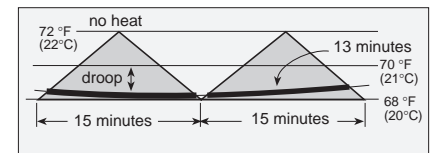

#### Derivative (D)

In order to speed up the control's response to quick changes in the heating load, derivative control logic is required. However, sudden room temperature changes, for example from an open door or window, should be ignored by an intelligent control.

#### P + I + D = PID

If proportional, integral and derivative (PID) control logic are combined, the control is more able to prevent excessive temperature swings and provide a stable room temperature under all conditions. It not only takes into account how much the room temperature has drooped, but also how long there has been a droop and how fast the temperature is changing.

### Zone Load Staggering

In a multiple zone system, there can be sudden load changes on the boiler and system due to multiple zones turning on or off. These sudden load changes often lead to boiler short cycling and unnecessary mechanical stresses. The operation of the system can be improved by staggering the starting points of each zone relay within the operating cycle. Staggering of the zones maintains a relatively constant system flow rate which improves boiler operation. Controlled staggering can also minimize boiler running time and improve system efficiency when only a few zones are needed for short periods.

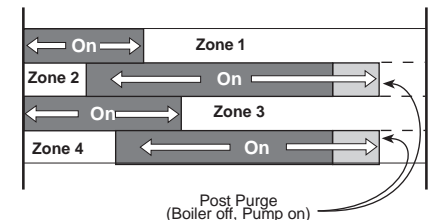

### Zone Post Purge

Before the last zone is turned off in a heating cycle, the boiler is turned off but the zone continues to draw heat from the boiler. This post purge of the boiler reduces stand-by losses and reduces overall energy consumption.

### UNOCCUPIED (NIGHT SETBACK)

During the night, or at times when people are not within the building, energy can be saved by lowering the building temperature for an UnOccupied (Night Setback) period.

Due to the large thermal mass of buildings, it takes a long time for the indoor space temperature to significantly change whenever the heating system is turned on or off. The building heat up or cool down time is further increased when high mass heating systems are used (e.g. radiant floors). In most cases night setback cannot be used with these systems due to the long recovery time required in the morning. A typical system is demonstrated in the diagram on page 3.

At the start of the night setback period the heat is turned off, but the heat contained within the slab or radiator continues to heat the building and there is a delay before the space temperature begins to drop. At the end of this delay the temperature within the building gradually decreases, and may eventually reach the required UnOccupied temperature after sufficient time has elapsed. Once the setback period is complete, the heat is turned on again but there is a long recovery time required to raise the space temperature to the desired setpoint. The length of the delay and recovery periods changes with outdoor temperature and is different for each zone within the building.

A comfortable setback can be provided if the control “learns” the response time for each zone within the building. Based on the zone’s response time, the control can then calculate an Optimum Stop time and an Optimum Start time. At the Optimum Stop time the control turns off the zone valve or pump in order to overcome the delay period and at the Optimum Start time, the control starts to raise the zone temperature in order to overcome the recovery period. This allows night setback to be used with most heating systems.

**Optimum Start / Stop with Water Temperature Boost**

When Optimum Start / Stop is combined with Outdoor Reset, the control can boost the water temperature during the recovery period. This provides a faster recovery and allows a longer setback for greater energy savings.

The accuracy of the Optimum Start / Stop routine depends on the feedback available to the control.

**Optimum Start / Stop with both Outdoor and Indoor Sensors**

The response time of the building varies with outdoor temperature and is also different for each zone. The most accurate Optimum Start / Stop routine is therefore achieved when both the indoor and outdoor temperatures are monitored during transitions between UnOccupied and Occupied modes.

**Optimum Start / Stop with only Indoor Sensors**

When only indoor temperature feedback is available, the control must base all Optimum Start / Stop calculations on indoor temperature only. If there are large variations in outdoor temperature, this method cannot provide the same level of accuracy as when both indoor and outdoor sensors are used.

**Optimum Start / Stop with only an Outdoor Sensor**

Every building, and often each zone within the building, has a different response time. When only an outdoor sensor is used, the control must assume a particular response time for the entire building. Therefore this is generally the least accurate method of calculating Optimum Start / Stop times.

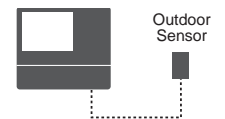
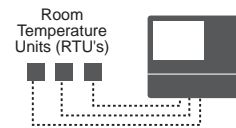
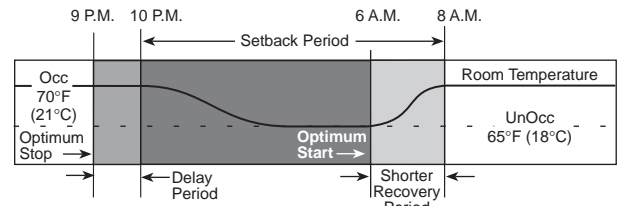
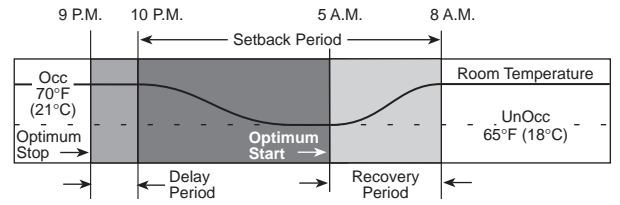
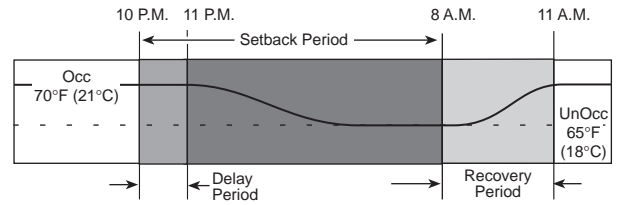

**Basic Sequence of Operation**

To use the basic features of the control, the DIP switches must be set to One & Two Stage and Zone 2 Heating and the Design Outdoor dial must be set to Off. More advanced features including modulating zones, free cooling and demand limiting are explained on page 10.



**POWERING UP THE CONTROL**

After the Zone Control 367 is powered up, a software version code is displayed for 2 seconds and then the red indicator lights are then turned on for 4 seconds. When the control is powered up, the green Power light remains on continuously. For the first fifteen minutes after power up, the Test light flashes and the control responds immediately to changes of settings. This allows the installer to test the operation of the system. After fifteen minutes, the control enters its normal operating mode in which reactions to setting changes are significantly slower. A slower reaction time to setting changes allows the control to provide a more stable room temperature.

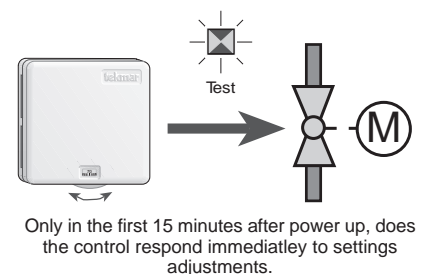

## ZONING OPERATION

The 367 can directly control the temperature of up to 6 One Stage heating zones or 3 Two Stage heating zones or a combination of One Stage and Two Stage zones. In order to measure the indoor temperature, each zone requires either an Indoor Sensor or a Room Temperature Unit (RTU). With an RTU the desired zone temperature is set using the RTU dial, but with an Indoor Sensor the desired zone temperature is fixed at 70°F (21°C). The *Max. Room* dial prevents the desired zone temperature from exceeding a maximum value (see Settings - page 9).

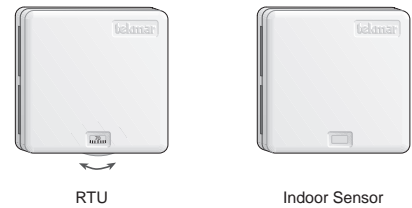

### Common Blocks

The 367 has 3 common blocks for both the RTU inputs and the relay outputs. Each common block has a terminal starting with *Com* (Eg. *Com Sen* or *Com 5-6*). Each common block can be used for either two One Stage zones or one Two Stage zone.

### One Stage Common Blocks

If an RTU is connected to the lowest number in the common block, a One Stage common block is created.

**Example** An RTU connected between the terminals *Com Sen* — *RTU 5* is used to control the output relay *5*, and an RTU connected between the terminals *Com Sen* — *RTU 6* is used to control the output relay *6*.

**Note** If only one RTU is used, it must be placed on the lower number in the common block. In the above example this would be *Com Sen* — *RTU 5* controlling output relay *Com 5-6* — *5*.

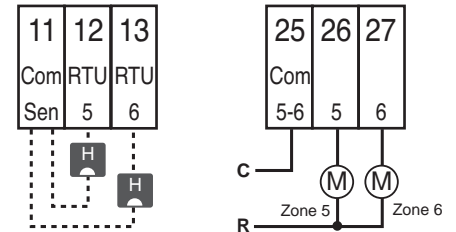

### PID Zoning Logic

The 367 operation is based on a 15 minute cycle. During every cycle, the control turns on each zone relay for a specific on time. The required on time is calculated based on the PID response of the zone during the previous 15 minute period. If the zone needs more heat, the on time is increased and if the zone needs less heat, the on time is reduced. In order to prevent short cycling, the 367 ensures that the zone relays remain on or off for at least 3 minutes.

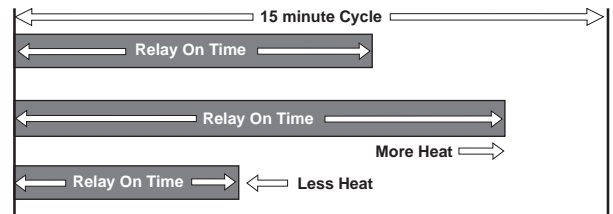

### Two Stage Common Blocks

When the DIP switch is set to *One & Two Stage* and a single RTU is connected to the highest terminal number in the common block, a Two Stage common block is created. The single RTU therefore controls two output relays: a *Lo stage* relay and a *Hi stage* relay.

**Example** An RTU connected between the terminals *Com Sen* — *RTU 2* is used to control the output relays *1* and *2*. Relay *1* is the *Lo stage* output relay and relay *2* is the *Hi stage* output relay.

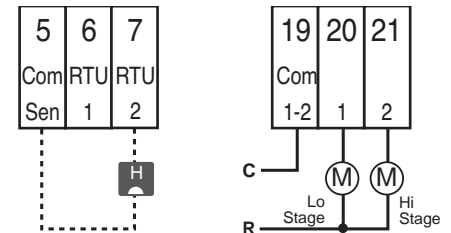

### PID Zoning logic

The temperature within each Two Stage zone is controlled by varying the on time of the output relays over a 15 minute period. During light loads, the 367 cycles the *Lo stage* relay on and off. As the load increases, the *Lo stage* relay on time increases until it reaches a maximum of 15 minutes. The *Hi stage* relay is then turned on and its on time is increased as the load increases. When the heating load decreases again, the on time of the *Hi stage* relay is reduced until the *Hi stage* relay is turned off completely. The control then starts to reduce the on time of the *Lo stage* relay.

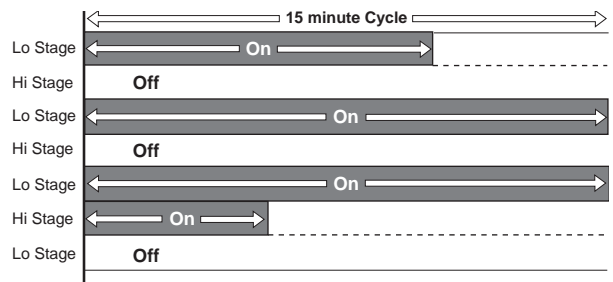

### Zone Control Load Staggering and Synchronization

The 367 staggers the operation of the zones in order to achieve a steady load on the boiler while minimizing boiler running time and preventing boiler short cycling. Multiple Zone Controls can be daisy chained together to increase the number of zones. Each of the Zone Controls synchronizes its zone operating cycles based on the *Zo In* input from the other Zone Controls. This results in a more stable system flow rate and improved boiler operation.

### Zone Control Operation with a tekmar Outdoor Reset Control

The 367 can provide indoor temperature feedback to a tekmar Reset Control. When multiple Zone Controls are used, each Zone Control sequentially passes the information to the tekmar Reset Control in order to ensure the zone with the highest heat requirement is satisfied. The *Heat Required* light is turned on whenever the 367 is requesting heat from the Reset Control.

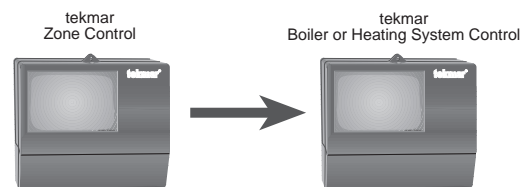

## Fast Acting Zone Valves or Zone Pumps

If the *Thermal Motor* DIP switch is set to *Off*, the 367 assumes that fast acting zone valves or zone pumps are connected to the zone relays. The system pump and *Heat Required* light are therefore turned on as soon as the first zone relay is operated. One minute before the last zone relay is turned off, the 367 purges the boiler by turning the *Heat Required* light off and keeping the system pump operating.

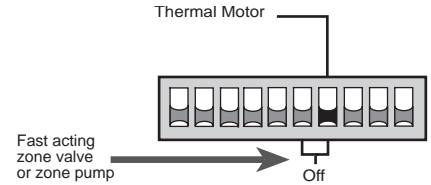

## Slow Acting Zone Valves with Thermal Motors

When the DIP switch is set to *Thermal Motor*, the 367 assumes that slow acting zone valves with thermal actuating motors are connected to the zone relays. With slow acting zone valves, the 367 allows a 3 minute period for the first zone valve to open before the system pump and *Heat Required* light are turned on. The total operating time for the zone relays is also increased by an extra 2 minutes. This helps compensate for the longer opening versus closing time of the slow acting zone valves. For one minute after the last zone relay is turned off, the 367 purges the boiler by turning the *Heat Required* light off and keeping the system pump operating.

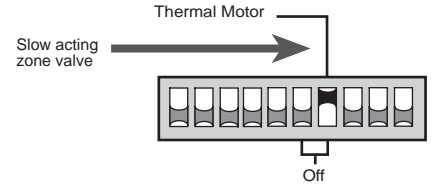

## COOLING OPERATION

When the DIP switch on the 367 is set to *Zone 1 Cooling*, output relay 1 can either be used to enable an auxiliary cooling control system or to directly operate a central cooling unit.

### Cooling Control (RTU is present)

If *Zone 1 Cooling* is selected and an RTU or Indoor Sensor is connected to terminals *Com Sen* — *RTU 1 (5 & 6)*, the 367 can directly control a central mechanical cooling system using output relay 1. If an RTU is used, the desired indoor temperature is set using the RTU dial down to 73°F (23°C), but if an Indoor Sensor is used, the desired indoor temperature is fixed at 77°F (25°C). Output relay 1 is allowed to turn on once the heating zones connected to the 367 have been satisfied for at least 45 minutes, and is turned off whenever any zone requires heat. The 367 varies the on time of output relay 1 over a 30 minute period. As the cooling load increases, the on time of the output relay increases. In order to prevent short cycling, the 367 ensures that the output relay remains on or off for at least 3 minutes.

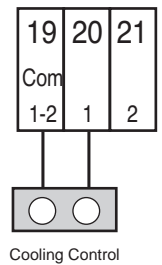
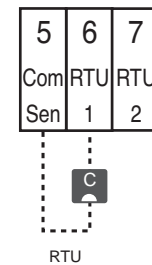

### Cooling Enable (No RTU)

If *Zone 1 Cooling* is selected and there is no RTU or Indoor Sensor connected to terminals *Com Sen* — *RTU 1 (5 & 6)*, the 367 can enable an auxiliary cooling control through output relay 1. Output relay 1 is turned on once the heating zones connected to the 367 have been satisfied for at least 45 minutes, and is turned off whenever any zone requires heat.

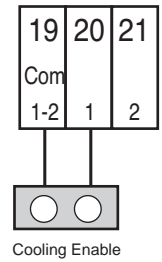
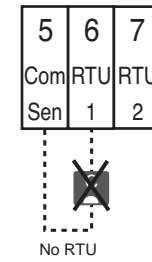

## UNOCCUPIED (NIGHT SETBACK)

The 367 can be switched into UnOccupied mode through the built in 24 hr. Timer or by closing an external switch or timer relay wired between the terminals *UnO Sw* — *Com Sen* (14 & 16) on the control.

### 24 hr. Timer

The 367 has a built in 24 hr. Timer which can be used to set a single UnOccupied event during a 24 hour period. The 24 hr. Timer is activated by pushing the *Start* button at the desired starting time for the UnOccupied period. The duration of the UnOccupied period is set using the *UnOccupied Duration* dial. Once the *Start* button is pushed, the *Timer Active* light is turned on and the 367 enters the UnOccupied mode each day at the same starting time. The 24 hr. Timer can be deactivated by pressing the *Start* button again. A new UnOccupied period starting time can be selected by repeating the above procedure.

**Note** If an external switch is closed between the terminals *UnO Sw* — *Com Sen* (14 & 16), the 24 hr. Timer is disabled. An external UnOccupied switch and the 24 hr. Timer should not be used at the same time.

- Occupied
- UnOccupied
- Optimum Start / Stop
- Timer Active

#### 24 hr. Timer

• Dial the desired duration of the UnOccupied period.  
 • Press start button at the time of day you want the UnOcc. period to begin. Timer Active light turns on.

0 = always Occupied  
24 = always UnOccupied

### UnOccupied Switch Input

A switch or external timer with a dry relay contact output can be wired between the terminals *UnO Sw* — *Com Sen* (14 & 16) on the 367. When the switch or relay contact is closed, the 367 registers an UnOccupied signal. A tekmar Timer 031 is available which can be programmed to provide individual UnOccupied schedules for each day of the week with up to two separate UnOccupied events per day. For more information on the Timer 031 see the Data Brochure D 031.

5

## UnOccupied Temperature

When the 367 is in UnOccupied mode, the *UnOccupied* light is turned on and the *UnOccupied* dial is used to set the desired temperature within the UnOccupied zones.

**Note** If the RTU dial for an UnOccupied zone is set below the *UnOccupied* dial, the 367 continues to use the RTU dial as the desired temperature within that zone.

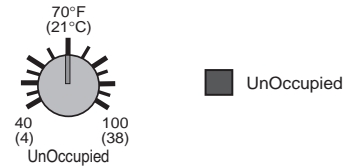

## Individual Zone Selection

The DIP switch on the 367 is used to select which zones are switched into UnOccupied mode. If the DIP switch for a specific zone is set to *Occ / UnOcc*, that zone is switched into UnOccupied mode whenever the 367 receives an UnOccupied signal. If the DIP switch for a specific zone is set to *Occ. only*, the zone remains in the Occupied mode at all times.

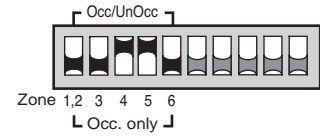

## Optimum Start / Stop

The Optimum Start / Stop feature is enabled when the DIP switch is set to *Optimum Start*. The 367 turns on the *Optimum Start / Stop* light each time the first zone enters its delay or recovery period. Either the tekmar Timer 031 or the built in 24 hr. Timer on the 367 can be used with the Optimum Start / Stop feature. The tekmar Timer 031 has a DIP switch which must be set to *Optimum Start / Stop* in order to synchronize the timer with the 367 Optimum Start / Stop function. For more information on the Timer 031 consult the Data Brochure D 031.

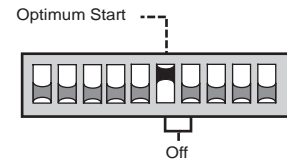

## SYSTEM PUMP OPERATION

The *System Pump* light is turned on every time the relay contact between terminals *System Pmp* — *System Pmp* (1 & 2) is closed. During heating operation, the system pump operates whenever any zone requires heat. If thermal motor zone valves are used, the system pump is held off for the first three minutes of the zone cycle in order to give the zone valve sufficient time to open. The system pump may also operate for an additional purge period once the zone relays are turned off.

## Pump / Valve Exercising

The zone valves, zone pumps and system pump are exercised to help prevent corrosion from building up and subsequently jamming the equipment. Every three days the 367 runs through the following exercising procedure.

### Exercising Procedure

The 367 first exercises the zone valves or pumps. If a zone valve or zone pump has not been operated in the past 3 days, the 367 turns on the zone relay for 10 seconds.

**Note** The zone relay exercising time is increased to 3 minutes if the DIP switch is set to *Thermal Motor*.

After the zone valves or pumps have been exercised, the 367 exercises the system pump. If the system pump has not operated in the past 3 days, the 367 turns on the *System Pmp* relay for 10 seconds.

Once the exercising procedure is complete, the 367 returns to its normal operating sequence.

## Basic Installation

### Caution

**Improper installation and operation of this control could result in damage to the equipment and possibly even personal injury. It is your responsibility to ensure that this control is safely installed according to all applicable codes and standards. This electronic control is not intended for use as a primary limit control. Other controls that are intended and certified as safety limits must be placed into the control circuit.**

## STEP ONE GETTING READY

Check the contents of this package. If any of the contents listed are missing or damaged, please contact your wholesaler or tekmar sales representative for assistance.

Type 367 includes:

- One Zone Control 367
- Data Brochures D 367, D 001
- Application Brochures A 367

Other information available:

- Essays

**Note** Carefully read the details of the *Sequence of Operation* sections in all applicable brochures to ensure that you have chosen the proper control for your application.

## STEP TWO MOUNTING THE BASE

Remove the control from its base by pressing down on the release clip in the wiring chamber and sliding the control upwards. The base is then mounted in accordance with the instructions in the Data Brochure D 001.

## STEP THREE ROUGH-IN WIRING

All electrical wiring terminates in the control base wiring chamber. The base has standard 7/8" (22 mm) knockouts which accept common wiring hardware and conduit fittings. Before removing the knockouts, check the wiring diagram and select those sections of the chamber with common voltages. Do not allow the wiring to cross between sections as the wires will interfere with safety dividers which should

be installed at a later time.

**Power must not be applied to any of the wires during the rough-in wiring stage.**

- *Optional* If an Outdoor Sensor 070 is used, install it according to the instructions in the Data Brochure D 070 and run two wires back to the control.
- If an Indoor Sensor 076 is used for any zone, install the Indoor Sensor(s) according to the instructions in the Data Brochure 070 and run the wiring back to the control.
- If an RTU 054 is used, install the RTU(s) according to the installation instructions provided in the Data Brochure D 054 and run the wiring back to the control.
- If multiple Zone Controls are used, run two wires from one Zone Control to the next to create a chain.
- Run wires from the 120 V (ac) power to the control. *Use a clean power source to ensure proper operation.* Multi-strand 16 AWG wire is recommended for all 120 V (ac) wiring due to its superior flexibility and ease of installation into the terminals.
- Run wiring from the system pump to the control.
- Run wires from each zone valve / pump to the control.

**STEP FOUR ————— ELECTRICAL CONNECTIONS TO THE CONTROL ———**

The installer should test to confirm that no voltage is present at any of the wires. Push the control into the base and slide it down until it snaps in firmly.

**Powered Input Connections**

**120 V (ac) Power**

Connect the 120 V (ac) power supply to terminals *Power N — L* (3 and 4).

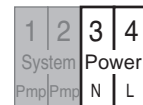

**Sensor and Unpowered Input Connections**

**Do not apply power to these terminals as this will damage the control.**

**Outdoor Sensor**

Connect the two wires from the Outdoor Sensor 070 to the terminals *Com Sen — Out Sen* (16 and 18). The Outdoor Sensor measures the outdoor air temperature.



**Zone Control Input and Output**

Connect a wire between the *Com Sen* (16) terminals on each 367. Connect the *Zo Out* terminal on the first 367 to the *Zo In* terminal on the second 367. With several Zone Controls, connect the *Zo Out* terminal on the second 367 to the *Zo In* terminal on the third 367 and continue this process for each additional 367. The *Zo Out* terminal on the last 367 in the chain can be connected to the *Zo In* terminal on a tekmar reset control.



**Note** The wires from the Zone Control are polarity sensitive. The system will not operate if the wires are reversed.

**Unoccupied Switch**

If an external timer or switch is used, connect the two wires from the external dry contact switch to the *UnO Sw — Com Sen* (14 and 16) terminals. When these terminals short together, the control registers an Unoccupied signal.

**Note** If an external switch is closed between the terminals *UnO Sw — Com Sen* (14 and 16), the 24 hr. Timer is disabled and the Optimum Start / Stop information is lost. It is recommended that either the 24 hr. Timer or an external timer / switch is used, not both at the same time.



**One Stage RTU and Indoor Sensor Connections**

RTUs and Indoor Sensors provide indoor temperature feedback to the control. It is best to start the One Stage zones at output relay 5 and work towards output relay 1.

**Common block for RTU 5 and RTU 6**

- If the common block is used for a single One Stage heating zone, connect the RTU or Indoor Sensor to terminals *Com Sen — RTU 5* (11 and 12).
- If the common block is used for 2 One Stage heating zones, connect one RTU or Indoor Sensor to the *Com Sen — RTU 5* (11 and 12) terminals and connect the other RTU or Indoor Sensor to the *Com Sen — RTU 6* (11 and 13) terminals.

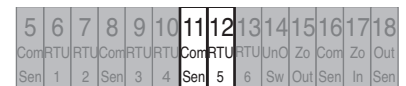

**Common block for RTU 4 and RTU 3**

- If the common block is used for a single One Stage heating zone, connect the RTU or Indoor Sensor to terminals *Com Sen — RTU 3* (8 and 9).
- If the common block is used for 2 One Stage heating zones, connect one RTU to the *Com Sen — RTU 3* (8 and 9) terminals and connect the other RTU to the *Com*



Sen — RTU 4 (8 and 10) terminals.

### Common block for RTU 1 and RTU 2

DIP switch set to Zone 1 Heating

- If the common block is used for a single One Stage heating zone, connect the RTU or Indoor Sensor to terminals *Com Sen* — RTU 1 (5 and 6).
- If the common block is used for 2 One Stage heating zones, connect one RTU to the *Com Sen* — RTU 1 (5 and 6) terminals and connect the other RTU to the *Com Sen* — RTU 2 (5 and 7) terminals.

DIP Switch set to Zone 1 Cooling

- If the 367 is used to enable a cooling system, then no RTU or Indoor Sensor is connected to terminal *Com Sen* — RTU 1 (5 and 6).
- If the 367 is used to control a cooling system the cooling RTU is connected to terminals *Com Sen* — RTU 1 (5 and 6).
- If a single stage heating zone is connected to output relay 2, connect the RTU or Indoor Sensor to terminals *Com Sen* — RTU 2 (5 and 7).

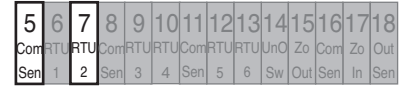
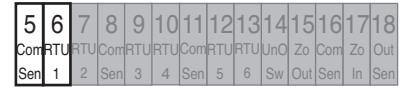

## Two Stage RTU and Indoor Sensor Connections

It is best to start the Two Stage heating zones at output relays 1 and 2 and work towards output relays 5 and 6.

### Common Block for RTU 1 and RTU 2

- If the common block is used for a Two Stage heating zone, connect the RTU or Indoor Sensor to terminals *Com Sen* — RTU 2 (5 and 7).

### Common Block for RTU 3 and RTU 4

- If the common block is used for a Two Stage heating zone, connect the RTU or Indoor Sensor to terminals *Com Sen* — RTU 4 (8 and 10).

### Common Block for RTU 5 and RTU 6

- If the common block is used for a Two Stage heating zone, connect the RTU or Indoor Sensor to terminals *Com Sen* — RTU 6 (11 and 13).

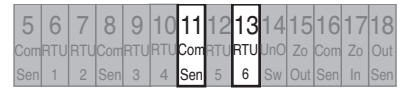
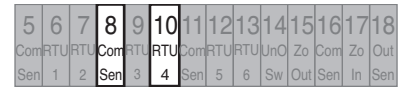
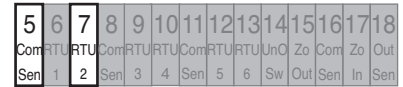

## Output Connections

### System Pump

Connect the live (L) side of the 120 V (ac) pump circuit through the *System Pmp* — *System Pmp* (1 and 2) terminals. The control closes a dry relay contact between these terminals when operation of the system pump is required.

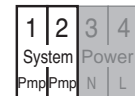

### Zone Pumps and Valves

**Note** Do not connect a zone pump and zone valve circuit to the same *Com* terminal.

- If relay 5 is used, connect the zone pump or zone valve circuit to the *Com 5-6* — 5 (25 and 26) terminals on the control.
- If relay 6 is used, connect the zone pump or zone valve circuit to the *Com 5-6* — 6 (25 and 27) terminals on the control.
- If relay 3 is used, connect the zone pump or zone valve circuit to the *Com 3-4* — 3 (22 and 23) terminals on the control.
- If relay 4 is used, connect the zone pump or zone valve circuit to the *Com 3-4* — 4 (22 and 24) terminals on the control.
- If relay 1 is used for heating (DIP switch set to *Zone 1 Heating*), connect the zone pump or zone valve to the *Com 1-2* — 1 (19 and 20) terminals on the control.
- If relay 2 is used, connect the zone pump or zone valve circuit to the *Com 1-2* — 2 (19 and 21) terminals on the control.

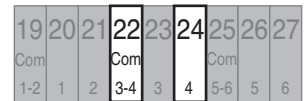
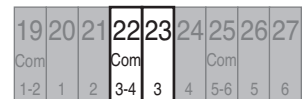

### Cooling System

If relay 1 is used for cooling (DIP switch set to *Zone 1 cooling*), connect the wires from the cooling unit isolation relay to terminals *Com 1-2* — 1 (19 and 20) on the control. The 367 closes a dry relay contact between these terminals when cooling is required.

## STEP FIVE — TESTING THE WIRING

**Each terminal block must be unplugged from its header on the control before power is applied for testing. Pull straight down to unplug the terminal block.**

The following tests are to be performed using standard testing practices and procedures and should only be carried out by properly trained and experienced persons.

A good quality electrical test meter, capable of reading from at least 0 — 200 V (ac) and at least 0 — 2,000,000 Ohms, is essential to properly test the wiring and sensors.

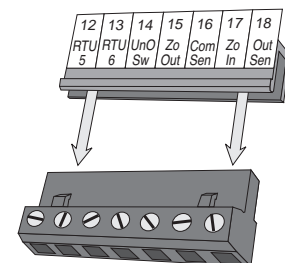

### Test the Sensors

In order to test the sensors and Room Temperature Units (RTUs), the actual temperature at each sensor and RTU location must be measured. A good quality digital thermometer with a surface temperature probe is recommended for ease of use and accuracy of testing. Where a digital thermometer is not available, a spare sensor can be strapped alongside the one to be tested and the readings compared. Test the sensors and RTU(s) according to the instructions in the Data Brochures D 070 and D 054.

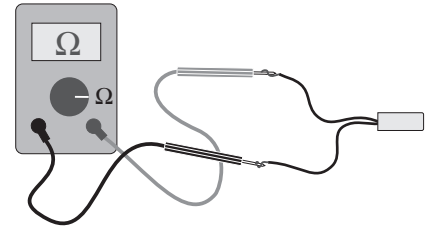

### Test the Power Supply

Make sure exposed wires or bare terminals are not in contact with other wires or grounded surfaces. Turn on the power and measure the voltage between the *Power N—L* (3 and 4) terminals using an AC voltmeter. The reading should be between 110 and 130 V (ac).

### Test the Outputs

#### System Pump

If a system pump is connected to the *System Pmp — System Pmp* (1 and 2) terminals, make sure power to the terminal block is off and install a jumper between the terminals. When the system pump circuit is powered up, the system pump should start. If the pump does not turn on, check the wiring between the terminal block and the pump and refer to any installation or troubleshooting information supplied with the pump. If the pump operates properly, disconnect the power and remove the jumper.

#### Cooling

If a cooling system is connected to the terminals *Com 1-2 — 1* (19 and 20), make sure power to the pump or valve circuit is off and install a jumper between the terminals *Com 1-2 — 1* (19 and 20). When the zone circuit is powered up, the zone pump should turn on or the zone valve should open completely. If no response occurs, check the wiring between the terminal and the pump or valve and refer to any installation or troubleshooting information supplied with these devices.

#### Zone Pump or Valve

- If a zone pump or valve is connected to the terminals *Com 5-6 — 6* (25 and 27), follow a similar procedure as described above in the cooling section for the zone 1 relay.
- If a zone pump or valve is connected to the terminals *Com 5-6 — 5* (25 and 26), follow a similar procedure as described above in the cooling section for the zone 1 relay.
- If a zone pump or valve is connected to the terminals *Com 3-4 — 4* (22 and 24), follow a similar procedure as described above in the cooling section for the zone 1 relay.
- If a zone pump or valve is connected to the terminals *Com 3-4 — 3* (22 and 23), follow a similar procedure as described above in the cooling section for the zone 1 relay.
- If a zone pump or valve is connected to the terminals *Com 1-2 — 2* (19 and 21), follow a similar procedure as described above in the cooling section for the zone 1 relay.
- If a zone pump or valve is connected to the terminals *Com 1-2 — 1* (19 and 20), follow a similar procedure as described above in the cooling section for the zone 1 relay.

### Connect the Control

- Make sure all power to the devices and terminal blocks is off and remove any remaining jumpers from the terminals.
- Reconnect the terminal blocks to the control by carefully aligning them with their respective headers on the control and then pushing the terminal blocks into the headers. The terminal blocks should snap firmly into place.
- Install the supplied safety dividers between the unpowered sensor inputs and the powered 120 V (ac) or 24V (ac) wiring chambers.
- Do not apply power to the control until the adjustment dials and DIP switches are properly set for your application. See the Basic Settings section of this brochure for details on how to set the dials and DIP switches.
- Once the settings are complete, apply power to the control. The operation of the control on power up is described in the Basic Sequence of Operation section of this brochure.

## Basic Settings

Before adjusting the dial settings, read through the sequence of operation section of this brochure to ensure that you understand how the control operates.

### STEP SIX ESSENTIAL CONTROL SETTINGS

#### Max. Room

The *Max. Room* dial is used to prevent excessive desired indoor temperature settings during heating operation. If an *RTU* dial is set above the *Max. Room* dial, the *Max. Room* dial becomes the desired indoor temperature. This is useful in situations where a tenant has control of the RTU but the owner pays the fuel costs.

#### Design Outdoor

This dial must be set to the *Off* position unless the Demand Limiting function is used. See the Advanced section of this brochure for more information.

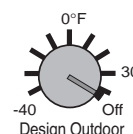
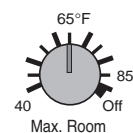

## Floating Motor Speed

This dial has no effect on the operation of the control unless modulating zone valves are used. See the Advanced section of this brochure for more information.

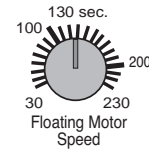

## Using the Internal 24 hr. Timer

First determine the length of time required for the UnOccupied period and turn the *UnOccupied Duration* dial to the desired duration length. If the dial is set to 24 hours, the 370 remains in UnOccupied mode continuously. If the dial is set to 0 hours, the 370 remains in Occupied mode continuously.

Press the *Start* button at the desired starting time for the UnOccupied period. Once the *Start* button is pressed, the 370 enters the UnOccupied period at the same starting time each day.

**Example** The user wants an UnOccupied period starting at 10 pm and ending at 6 am. The *UnOccupied Duration* dial is set to 8 hours and the *Start* button is pushed at 10 pm. Once the *Start* button is pushed, the control goes into UnOccupied mode from 10 pm until 6 am the next morning. This cycle is repeated 7 days a week.

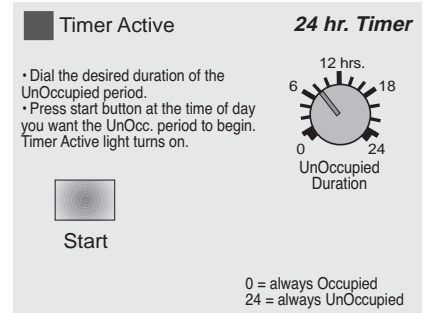

## DIP Switch Settings

### Occ / UnOcc — Occ. Only

Each zone can be selected to operate in either Occupied only mode or both Occupied and UnOccupied modes. If the DIP switch is set to *1,2 Occ. only*, the zones connected to relays 1 and 2 remain in the Occupied mode at all times. If the DIP switch is set to *1,2 Occ/UnOcc*, zones 1 and 2 are switched into UnOccupied mode each time the 367 receives an UnOccupied signal. Zones 3, 4, 5 and 6 can be individually selected for Occupied only or both UnOccupied and Occupied mode operation. If Two Stage zones are used, the DIP switches for both output relays should be set to the same position.

### Optimum Start

The Optimum Start / Stop feature is used during transitions between the UnOccupied mode (Night Setback) and the Occupied mode. When the DIP switch is set to *Optimum Start*, the 367 raises the building temperature during the final stages of the UnOccupied period. This helps ensure the building is at the Occupied temperature as soon as the Occupied period begins. If the *Optimum Start* DIP switch is set to *Off*, the 367 does not start raising the building temperature until the UnOccupied period ends. More information on the Optimum Start feature is provided on page 2 of this brochure.

### Thermal Motor

Zone valves with thermal actuating motors have long opening and closing times. In order for the 367 to compensate for these longer times, the DIP switch should be set to *Thermal Motor*. If fast acting electric motor zone valves or zone pumps are used, the DIP switch must be set to *Off*.

### One Stage & Floating / One & Two Stage

This DIP switch must be set to the *One & Two Stage* position unless modulating zones are used. See the Advanced section of this brochure for more information.

### Zone 1 Cooling / Zone 1 Heating

The zone 1 relay can be used to control a heating zone or to enable or control a cooling system. If zone 1 is to be used for heating, the DIP switch must be set to *Zone 1 Heating*. If zone 1 is used for cooling, the DIP switch must be set to *Zone 1 Cooling*.

### Zone 2 Ventilating / Zone 2 Heating

This DIP switch must be set to the *Zone 2 Heating* position unless ventilation or free cooling is desired. See the Advanced section of this brochure for more information.

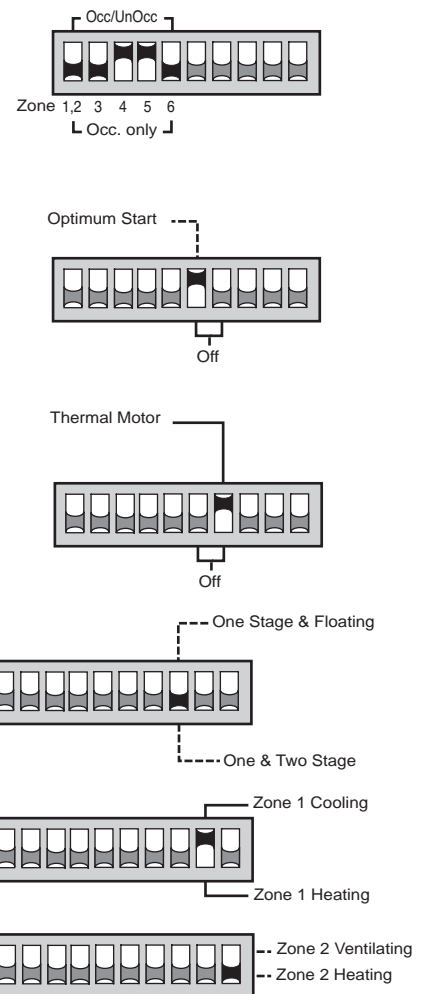

## Advanced Sequence of Operation

A thorough understanding of the basic features of this control should be obtained before reading the advanced section.

### MODULATING ZONES

When the DIP switch is set to *One Stage & Floating*, the 367 can control up to 6 One Stage zones or 3 Floating Action zones or a combination of single stage and floating zones. Floating zones allow the control to operate modulating zone valves.

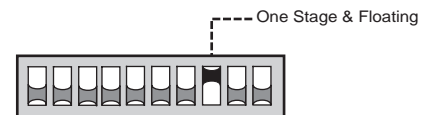

## Common Blocks

The 367 has 3 common blocks for both the RTU inputs and relay outputs. Each common block has a terminal starting with *Com* (e.g. *Com Sen* or *Com 1-2*). When the DIP switch is set to *One Stage & Floating*, each common block can be used for either two One Stage zones or one Floating action zone. One Stage common blocks are explained on page 4 of this brochure.

## Floating Action Common Blocks

When the DIP switch is set to *One Stage & Floating* and a single RTU is connected to the highest terminal number in the common block, a Floating Action zone is created. The single RTU controls two relay outputs - an *Open* relay and a *Close* relay. The *Motor Speed* dial is used to set the time required for the floating action actuating motor to go from fully closed to fully open.

**Example** An RTU connected between the terminals *Com Sen* — *RTU 2*, is used to control the output relays 1 and 2. Relay 1 is the *Open* relay and relay 2 is the *Close* relay.

Each floating zone is controlled by repositioning the floating action valve every 15 minutes based on the space temperature in the zone. The control uses PID logic to maintain an accurate space temperature. When the measured space temperature is above or below the desired setpoint, the 367 calculates a new position for the valve and then operates the *close* or *open* relay in order to achieve the new position. The floating action output is designed for either linear modulating injection valves that change the supply water temperature to the terminal unit or equal percentage modulating valves that change the flowrate through the terminal unit.

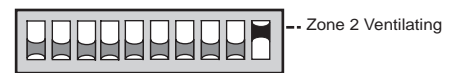
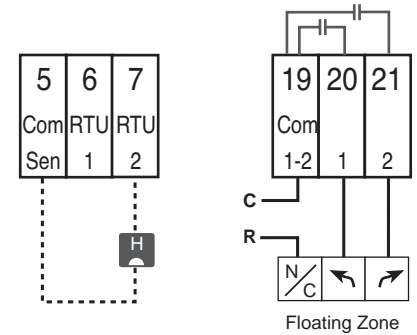
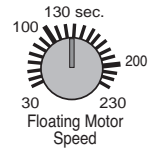

## VENTILATION

The 367 can be used to operate a ventilation system. When the DIP switch on the 367 is set to *Zone 2 Ventilating*, the 367 ignores the *RTU 2* terminal and utilizes the output relay 2 to operate the ventilation system. During the Occupied period, the output relay 2 is turned on, and during the UnOccupied period the output relay 2 is turned off. The ventilation system is therefore only operated during occupied periods in order to conserve energy. If *Optimum Start* is selected, the 367 starts the ventilation system one hour before the Occupied period begins. This allows sufficient time to purge the air for normal occupancy.

## FREE COOLING

If the DIP switches are set to both *Zone 1 Cooling* and *Zone 2 Ventilating*, the 367 can operate a fan and damper to bring outside air into the building for free cooling. An Indoor Sensor or RTU must be connected between terminals *Com Sen* — *RTU 1* and an Outdoor Sensor must be connected to *Com Sen* — *Out Sen*. Whenever cooling is needed and the heating zones have been satisfied for at least 45 minutes and the outdoor air temperature is at least 3°F colder than the indoor air temperature, the 367 turns on relays 1 and 2 together. The 367 varies the on time of output relays 1 and 2 over a 30 minute period. As the cooling load increases, the on time of the output relays increases.

## Combining Ventilation, Free Cooling & Mechanical Cooling

All three systems (ventilation, free cooling and mechanical cooling) can be operated through the appropriate wiring, as shown in the adjacent diagram. When the 367 is used to operate all three systems, the output relay 2 (ventilation) is turned on during occupied periods whenever cooling is not being done. The 367 operates both output relay 1 and output relay 2 (free cooling) when cooling is required and the outdoor temperature is below the desired indoor temperature. When the outdoor temperature is warmer than the desired indoor temperature, the 367 turns off output relay 2 and turns on output relay 1 in order to run the mechanical cooling system.

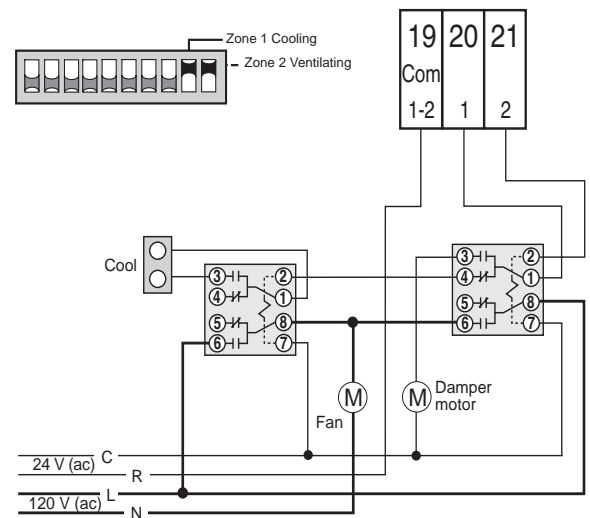

## DEMAND LIMITING (Design Outdoor dial)

The heat supplied to the zones can be limited based on outdoor temperature. Demand Limiting is an energy saving function that is used to prevent excessive energy consumption when there is an unnecessary heating load such as an open window during moderate outdoor conditions. This function should only be used if the 367 is not connected to a tekmar reset control. When the *Design Outdoor* dial is turned up from the *Off* position and an outdoor sensor is present, the demand limiting function is enabled. Based on the outdoor temperature, the control restricts the maximum on time of the zone relays. The control allows a full 15 minute on time when the outdoor temperature reaches the temperature set on the *Design Outdoor* dial. Above this temperature the maximum on time is reduced until the outdoor temperature reaches the WWSD point where the maximum on time is zero.

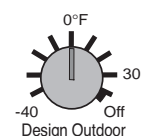

## Advanced Installation

This section supplements the basic installation that begins on page 6.

### Sensor and Unpowered Input Connections

**Do not apply power to these terminals as this will damage the control.**

#### Floating Action RTU and Indoor Sensor Connections

It is best to start the Floating Action heating zones at output relays 1 and 2 and work towards output relays 5 and 6.

##### Common Block for RTU 1 and RTU 2

If the *Com 1-2* (19) common block is used for a floating zone, connect the RTU or Indoor Sensor to terminals *Com Sen — RTU 2* (5 and 7).

##### Common Block for RTU 3 and RTU 4

If the *Com 3-4* (22) common block is used for a floating zone, connect the RTU or Indoor Sensor to terminals *Com Sen — RTU 4* (8 and 10).

##### Common Block for RTU 5 and RTU 6

If the *Com 5-6* (25) common block is used for a floating zone, connect the RTU or Indoor Sensor to terminals *Com Sen — RTU 6* (11 and 13).

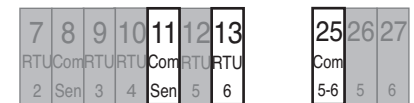
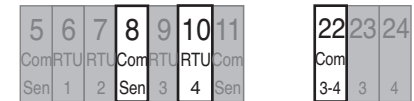

### Output Connections

#### Ventilation

If the DIP switch is set to *Zone 2 Ventilating*, connect the 24 V (ac) or 120 V (ac) isolation relay to the *Com 1-2 — 2* (19 and 21) terminals.

#### Free Cooling

If the DIP switches are set to *Zone 1 Cooling* and *Zone 2 Ventilating*, the wiring diagram on the previous page can be followed for connecting the free cooling damper(s) and fan(s) to the control.

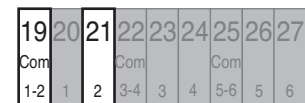

#### Floating Zones

##### Common Block *Com 1-2*

If the *Com 1-2* common block is used to control a floating action zone valve, wire one side of the 24 V (ac) circuit to terminal *Com 1-2* (19). The output relay 1 (terminal 20) is then connected to the open terminal on the actuating motor and the output relay 2 (terminal 21) is connected to the close terminal on the actuating motor.



##### Common Block *Com 3-4*

If the *Com 3-4* common block is used to control a floating action zone valve, wire one side of the 24 V (ac) circuit to terminal *Com 3-4* (22). The output relay 3 (terminal 23) is then connected to the open terminal on the actuating motor and the output relay 4 (terminal 24) is connected to the close terminal on the actuating motor.

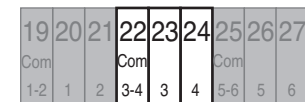

##### Common Block *Com 5-6*

If the *Com 5-6* common block is used to control a floating action zone valve, wire one side of the 24 V (ac) circuit to terminal *Com 5-6* (25). The output relay 5 (terminal 26) is then connected to the open terminal on the actuating motor and the output relay 6 (terminal 27) is connected to the close terminal on the actuating motor.



### Test the Outputs

Test the sensors, power supplies, system pump, cooling and on / off zones according to the procedure given on page 9.

#### Ventilation

If output relay 2 is used to control a ventilation system, make sure power to the ventilation unit is off and install a jumper between the terminals *Com 1-2 — 2* (19 and 21). When the ventilation circuit is powered up, the ventilation system should turn on. If it does not, check the wiring between the terminals and the ventilation unit and refer to any installation or troubleshooting information supplied with the fan.

#### Free Cooling

If output relays 1 and 2 are used to control a fan and damper, make sure power to the free cooling system is off and install jumpers between the terminals *Com 1-2 — 1* (19 and 20) and *Com 1-2 — 2* (19 and 21). When the circuit is powered up, the free cooling system should turn on. If it does not, check the wiring between the terminals and relays and also check the wiring to the fan and damper. Refer to any installation or troubleshooting information supplied with these devices.

## Floating Action Zones

- If a floating action actuating motor is connected to the terminals *Com 1-2—1—2* (19, 20 and 21), make sure power to the motor circuit is off and install a jumper between the terminals *Com 1-2—1* (19 and 20). When the circuit is powered up, the valve should start to open. If it does not, check the wiring between the terminal and the actuating motor and refer to any installation or troubleshooting information supplied with the motor. If the valve closes instead of opening, the wiring to the actuating motor must be reversed. If the valve opens correctly, turn off the power to the circuit and remove the jumper. Install a jumper between the terminals *Com 1-2—2* (19 and 21). When the circuit is powered up, the valve should start to close. If it does not, check the wiring between the terminal and the actuating motor and refer to any installation or troubleshooting information supplied with the motor. If the valve closes correctly, turn off the power to the circuit and remove the jumper.
- If a floating action actuating motor is connected to the terminals *Com 3-4—3—4* (22, 23 and 24), follow a similar procedure to that described above.
- If a floating action actuating motor is connected to the terminals *Com 5-6—5—6* (25, 26 and 27), follow a similar procedure to that described above.

## Advanced Settings

### Design Outdoor

If the *Design Outdoor* dial is turned up from the *Off* position the Demand Limiting function is enabled. The *Design Outdoor* dial determines the outdoor temperature at which full heating output is required.

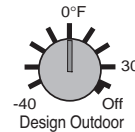

### Floating Motor Speed

This dial is used to set the time required for the modulating valve to go from fully closed to fully open.

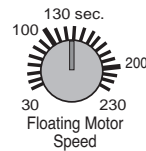

### Zone 2 Ventilating / Zone 2 Heating

If this DIP switch is set to *Zone 2 Ventilating*, the 367 can operate a ventilation system through output relay 2. If the DIP switches are set to *Zone 1 Cooling* and *Zone 2 Ventilating*, the 367 can operate a free cooling system through output relays 1 and 2. If the DIP switch is set to *Zone 2 Heating* the 367 operates output relay 2 as a heating zone.



## Testing the Control Functions

### STEP SEVEN — OPERATIONAL TEST OF CONTROL FUNCTIONS

The Zone Control 367 has a test routine which is used to test the main control functions. The 367 continually checks the sensors and displays an error message whenever a fault is found. See page 15 for the list of error messages. When the *Test* button is pushed, the *Test* light is turned on. The *Heat Required*, and *Optimum Start / Stop* lights are turned off and the individual outputs and relays are tested in the following test sequence.

### Test Sequence

Each step in the test sequence lasts 10 seconds. At the end of each step, the device continues to operate until it is turned off in a later step.

During the test routine, the test sequence can be paused by pressing the *Test* button. The test sequence remains paused at that point for up to 5 minutes. If the *Test* button is not pressed again while the test sequence is paused, the control exits the entire test routine. Once the test sequence is paused, the *Test* button can be pressed again to skip to the next step. This can also be used to rapidly skip through the test sequence. To reach the desired step, repeatedly press and release the *Test* button until the appropriate device and indicator light turn on.

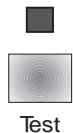

*Step 1* - The *System Pump* relay is turned on.

*Step 2* - If the *Com 5-6* common block is used for a single One Stage zone, the control turns on relay 5 for 10 seconds.

- If the *Com 5-6* common block is used for two One Stage zones, the control turns on relay 5 for 10 seconds and then turns off relay 5 and turns on relay 6 for 10 seconds.
- If the *Com 5-6* common block is used for a Two Stage zone, the control turns on relay 5 and then, after 10 seconds, turns on relay 6.
- If the *Com 5-6* common block is used for a Floating zone, the control turns on relay 5 for 10 seconds and then turns off relay 5 and turns on relay 6 for 10 seconds.
- If an RTU is not connected to *RTU 5* or *RTU 6*, the control skips this step.

①	■ System Pump
②	■ System Pump
	■ Zone 1 / Lo stage / Open / Cooling
	■ Zone 2 / Hi stage / Close / Ventilation
	■ Zone 3 / Lo stage / Open
	■ Zone 4 / Hi stage / Close
5	■ Zone 5 / Lo stage / Open
6	■ Zone 6 / Hi stage / Close

*Step 3* - The control tests relays 3 and 4 using the procedure described in Step 2.

*Step 4* - If the DIP switches are set to *Zone 1 Heating* and *Zone 2 Heating*, the control tests relays 1 and 2 using the procedure described in Step 2.

- If the DIP switch is set to *Zone 2 Ventilating* or its is set to *Zone 2 Heating* and an RTU is connected to *RTU 2*, the control turns on relay 2 for 10 seconds.
- If the DIP switch is set to *Zone 1 Cooling* or an RTU is connected to *RTU 1* the control turns on relay 1 for 10 seconds.

*Step 5* - After the test sequence is complete, the *Test* light begins flashing and the control enters a fast mode of operation. During this time, the control is more responsive to setting adjustments. If the dial on an RTU is turned up, the on time of the zone relay increases immediately. After fifteen minutes, the control reverts back to normal operating conditions and the on times are based on the average temperature during the previous 15 minute cycle.

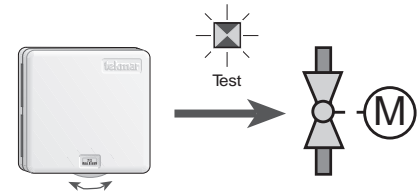

Adjusting RTU settings provides an immediate response for the first 15 minutes only.

### Manual Test

While the control is in the fast mode of operation and the *Test* light is flashing, check that each RTU operates the proper zone valve or zone pump. Turn up the *RTU* dial to turn the zone on, turn the dial down to turn the zone off. If an Indoor Sensor is used, a cold spray to the sensor will turn the zone on.

### Indicator Lights “On”

<i>Power</i>	• 120 V (ac) power is applied to the control and the control is energized.
<i>Heat Required</i>	• The 367 is sending a heat required signal to a tekmar reset control. At least one of the heating zones requires heat.
<i>System Pump</i>	• The relay contact between <i>System Pmp</i> — <i>System Pmp</i> (1 and 2) is closed and the System Pump should be turned on.
<i>Zone 1 / Lo Stage / Open / Cooling</i>	• The relay contact between <i>Com 1-2</i> — 1 (19 and 20) is closed and the device connected to this relay should be turned on.
<i>Zone 2 / Hi Stage / Close / Ventilation</i>	• The relay contact between <i>Com 1-2</i> — 2 (19 and 21) is closed and the device connected to this relay should be turned on.
<i>Zone 3 / Lo Stage / Open</i>	• The relay contact between <i>Com 3-4</i> — 3 (22 and 23) is closed and the device connected to this relay should be turned on.
<i>Zone 4 / Hi Stage / Close</i>	• The relay contact between <i>Com 3-4</i> — 4 (22 and 24) is closed and the device connected to this relay should be turned on.
<i>Zone 5 / Lo Stage / Open</i>	• The relay contact between <i>Com 5-6</i> — 5 (25 and 26) is closed and the device connected to this relay should be turned on.
<i>Zone 6 / Hi Stage / Close</i>	• The relay contact between <i>Com 5-6</i> — 6 (25 and 27) is closed and the device connected to this relay should be turned on.
<i>Test</i>	• The control is proceeding through the programmed test sequence.
<i>Occupied</i>	• The control is in Occupied mode.
<i>UnOccupied</i>	• The control is in UnOccupied (Night Setback) mode.
<i>Optimum Start / Stop</i>	• The control is warming the building up during the final stages of the UnOccupied period, or the heating system is turned off during the final stages of the Occupied period.
<i>Timer Active</i>	• The timer is set to enter the UnOccupied mode every 24 hours at the time of day the <i>Start</i> button was pressed.

## STEP EIGHT TROUBLESHOOTING

As in any troubleshooting procedure, it is important to isolate a problem as much as possible before proceeding. The Error Messages and *Test* button greatly simplify troubleshooting of the 367. When the control is flashing an error message, identify the fault from the look-up table on page 15 and follow standard testing procedures to confirm the problem. If you suspect a wiring fault, return to steps three, four and five, and carefully check all external wiring and wiring connections.

### Sensor and Internal Faults

- If an Outdoor Sensor fault occurs, the 367 operates as if an Outdoor Sensor is not connected. An error message is displayed.
- If an RTU / Indoor Sensor fault occurs or an external Zone Control input *Zo - in* short circuits, the 367 operates as if that RTU or Zone Control is not connected. An error message is displayed.
- If an internal control fault occurs, the 367 displays an error message. Press the *Test* button to clear the error message. If the error message remains, the control must be returned for repair.

## STEP NINE — BEFORE YOU LEAVE

- Make sure the wiring safety dividers are installed in their proper locations between compartments with different voltages.
- Install the wiring cover over the wiring chamber and secure it to the base with the two screws provided. Place the front cover on the control and snap it into place. Install a lock if security is required.
- A sticker has been provided with the control. It is designed to be placed over the Zone 1 ... Zone 6 words so that the zone names can be written onto the control.
- Place this brochure, and all other brochures relating to the installation, in the protective plastic bag supplied with the control.
- Place the bag in a conspicuous location near the control for future reference.
- It is important to explain the operation of the control to the end user and to anyone else who may be operating the system.

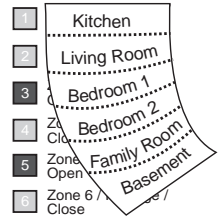

## Error Messages

Whenever a fault is detected in any of the sensors and / or room temperature units (RTUs), the indicator lights will flash in specific ways, to indicate the location of the problem. For detailed Sensor and RTU testing instructions see Data Brochures D 070 and D 054.

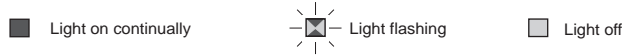

<p><b>Internal fault</b></p> <p>Occupied (flashing)    Power (on)</p> <p>UnOccupied (flashing)    Heat Required (off)</p> <p>Optimum Start / Stop (flashing)</p> <p>Timer Active (flashing)</p>	<p><b>Outdoor sensor short circuit</b></p> <p>Occupied (off)    Power (on)</p> <p>UnOccupied (flashing)    Heat Required (flashing)</p> <p>Optimum Start / Stop (flashing)</p> <p>Timer Active (off)</p>	<p><b>Outdoor sensor open circuit (design out ≠ off)</b></p> <p>Occupied (off)    Power (on)</p> <p>UnOccupied (flashing)    Heat Required (flashing)</p> <p>Optimum Start / Stop (flashing)</p> <p>Timer Active (off)</p>	<p><b>Zo — in short circuit</b></p> <p>Occupied (off)    Power (on)</p> <p>UnOccupied (flashing)    Heat Required (off)</p> <p>Optimum Start / Stop (flashing)</p> <p>Timer Active (off)</p>
<p><b>RTU 1 short circuit</b></p> <p>Occupied (flashing)    Power (on)</p> <p>UnOccupied (flashing)    Heat Required (off)</p> <p>Optimum Start / Stop (flashing)</p> <p>Timer Active (off)</p>	<p><b>RTU 2 short circuit</b></p> <p>Occupied (flashing)    Power (on)</p> <p>UnOccupied (flashing)    Heat Required (off)</p> <p>Optimum Start / Stop (flashing)</p> <p>Timer Active (off)</p>	<p><b>RTU 3 short circuit</b></p> <p>Occupied (flashing)    Power (on)</p> <p>UnOccupied (flashing)    Heat Required (off)</p> <p>Optimum Start / Stop (flashing)</p> <p>Timer Active (off)</p>	<p><b>RTU 4 short circuit</b></p> <p>Occupied (off)    Power (on)</p> <p>UnOccupied (flashing)    Heat Required (off)</p> <p>Optimum Start / Stop (flashing)</p> <p>Timer Active (off)</p>
<p><b>RTU 5 short circuit</b></p> <p>Occupied (off)    Power (on)</p> <p>UnOccupied (flashing)    Heat Required (off)</p> <p>Optimum Start / Stop (flashing)</p> <p>Timer Active (off)</p>	<p><b>RTU 6 short circuit</b></p> <p>Occupied (off)    Power (on)</p> <p>UnOccupied (flashing)    Heat Required (off)</p> <p>Optimum Start / Stop (flashing)</p> <p>Timer Active (off)</p>	<p><b>RTU 1 Temperature sensor missing</b></p> <p>Occupied (flashing)    Power (on)</p> <p>UnOccupied (flashing)    Heat Required (off)</p> <p>Optimum Start / Stop (flashing)</p> <p>Timer Active (off)</p>	<p><b>RTU 2 Temperature sensor missing</b></p> <p>Occupied (flashing)    Power (on)</p> <p>UnOccupied (flashing)    Heat Required (off)</p> <p>Optimum Start / Stop (flashing)</p> <p>Timer Active (off)</p>
<p><b>RTU 3 Temperature sensor missing</b></p> <p>Occupied (flashing)    Power (on)</p> <p>UnOccupied (flashing)    Heat Required (off)</p> <p>Optimum Start / Stop (flashing)</p> <p>Timer Active (off)</p>	<p><b>RTU 4 Temperature sensor missing</b></p> <p>Occupied (off)    Power (on)</p> <p>UnOccupied (flashing)    Heat Required (off)</p> <p>Optimum Start / Stop (flashing)</p> <p>Timer Active (off)</p>	<p><b>RTU 5 Temperature sensor missing</b></p> <p>Occupied (off)    Power (on)</p> <p>UnOccupied (flashing)    Heat Required (off)</p> <p>Optimum Start / Stop (flashing)</p> <p>Timer Active (off)</p>	<p><b>RTU 6 Temperature sensor missing</b></p> <p>Occupied (off)    Power (on)</p> <p>UnOccupied (flashing)    Heat Required (off)</p> <p>Optimum Start / Stop (flashing)</p> <p>Timer Active (off)</p>

## Technical Data

### Zone Control 367 One & Two Stage / One Stage & Floating

Literature	— D 367, A 367, D 001, Essays
Control	— Microprocessor PID control; This is <b>not a safety (limit) control</b> .
Packaged weight	— 3.1 lb. (1400 g), Enclosure A, PVC plastic
Dimensions	— 6-5/8" H x 7-9/16" W x 2-13/16" D (170 x 193 x 72 mm)
Approvals	— CSA NRTL / C, meets ICES & FCC regulations for EMI/RFI.
Ambient conditions	— Indoor use only, 32 to 122°F (0 to 50°C), < 90% RH non-condensing.
Power supply	— 120 V ±10% 50/60 Hz 8 VA
Pump Relay	— 120 V (ac) 10 A 1/3 hp, pilot duty 240 VA
Zone Relays	— 120 V (ac) 6 A 1/3 hp, pilot duty 240 VA
Maximum linkage	— Up to 6 Zone Controls can be linked to a tekmar reset control.
Sensors	— NTC thermistor, 10 kΩ @ 77°F (25°C ±0.2°C) β=3892
included:	None.
required:	RTU 054 or Indoor Sensor 076 for each active zone. (Order separately)
optional:	Outdoor Sensor 070.
Timer	— 24 hour, 1 event / day, 3 minute backup
UnOcc. Duration	— 0 to 24 hours
Unoccupied	— 40 to 100°F (4 to 38°C)

Max. Room	— 40 to 86°F, Off (4 to 30°C, Off)
Design Outdoor	— -40 to 32°F, Off (-40 to 0°C, Off)
Floating Motor Speed	— 30 to 230 seconds

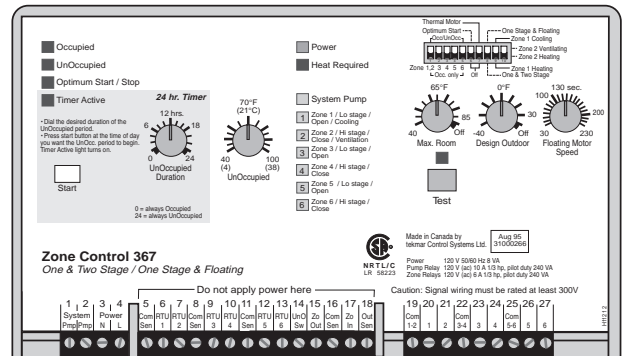

The installer must ensure that this control and its wiring are isolated and/or shielded from strong sources of electromagnetic noise. Conversely, this Class B digital apparatus complies with Part 15 of the FCC Rules and meets all requirements of the Canadian Interference-Causing Equipment Regulations. However, if this control does cause harmful interference to radio or television reception, which can be determined by turning the control off and on, the user is encouraged to try to correct the interference by reorienting or relocating the receiving antenna, relocating the receiver with respect to this control, and/or connecting the control to a different circuit from that to which the receiver is connected.

Cet appareil numérique de la classe B respecte toutes les exigences du Règlement sur le matériel brouilleur du Canada.

**Caution** The nonmetallic enclosure does not provide grounding between conduit connections. Use grounding type bushings and jumper wires.

**Attention** Un boîtier nonmétallique n'assure pas la continuité électrique des conduits. Utiliser des manchons ou des fils de accord spécialement conçus pour la mise à la terre.

## Limited Warranty and Product Return Procedure

**Limited Warranty** The liability of tekmar Control Systems Ltd. and tekmar Control Systems, Inc. ("tekmar") under this warranty is limited. Please read and understand the conditions appearing herein.

tekmar warrants each tekmar product against defects in workmanship and materials, when the product is installed and used in compliance with tekmar's instructions. The warranty period is for a period of twenty-four (24) months from the production date if the product is not installed during that period, or twelve (12) months from the documented date of installation if installed within twenty-four (24) months from the production date, but in any event the warranty period shall not extend beyond thirty-six (36) months from the production date. During the warranty period, tekmar will, at its discretion, either repair at no charge, exchange or give credit for the defective product, provided the product is returned to tekmar.

The liability of tekmar shall be limited to the cost of parts and labour provided by tekmar to correct defects in materials and / or work-manship or to the exchange of the defective product for a replacement product or to the granting of credit limited to the original cost of the product, at tekmar's discretion, and such repair, exchange or credit shall be deemed to be the sole remedy available from tekmar. This warranty does not cover the cost of the parts or labour to remove or to transport the defective product, or to reinstall the repaired or replacement product. Returned products that are not defective are not covered by this warranty.

This warranty does not apply if the product has been damaged by accident, abuse, misuse, negligence, fire, Act of God, or has been damaged by modifications, alterations or attachments made subsequent to purchase which have not been authorized by tekmar, or if the product was not installed in compliance with the local codes and ordinances, or if due to defective installation of the product.

The warranty applicable to a product is as set out in the statement of warranty policy (the "Warranty") above, receipt of which is hereby acknowledged. The liability of tekmar is limited to those obligations identified in the warranty as obligations of tekmar. The warranty is understood to be in substitution for any loss, costs or damages for which tekmar might otherwise be liable at law or in equity and in particular, in lieu of any liability for fundamental breach of contract.

tekmar disclaims any responsibility for losses, expenses, inconveniences, or any special, indirect, secondary, incidental or consequential damages arising from ownership or use of any items subject to any claim hereunder, regardless of whether such claim is stated in contract, tort or strict product liability.

This warranty is in lieu of all other warranties, express or implied, including, without limitation, warranties of merchantability, fitness for a particular purpose, durability or description of the product, its non-infringement of any relevant patents or trademarks, and its compliance with or non-violation of any applicable environmental, health or safety legislation. No implied warranties shall extend beyond twenty-four (24) months from the production date.

Some states or provinces do not allow limitations on how long an implied warranty lasts, so the above limitation may not apply to you. This warranty gives you specific legal rights, and you may also have other rights which vary from state to state or province to province.

**Product Return Procedures** Products that are believed to have defects in workmanship or materials must be returned, together with a written description of the defect, to the tekmar representative for that territory. If the address of the representative is not known, please request it from tekmar at the telephone number listed below.

**In North America:** tekmar Control Systems Ltd., Canada  
tekmar Control Systems, Inc., U.S.A.  
Head Office: 4611 - 23rd Street  
Vernon, B.C. Canada V1T 4K7  
Tel. (604) 545-7749 Fax. (604) 545-0650