

The Snow/Ice Detector consists of a plug-in control and base which is located in a building, and an electronic sensor with waterproof connecting cable and socket which is installed into the travelled surface. Typical applications include driveways, sidewalks, bridges, ramps, and stairways.

Whenever there is the presence of snow or ice on the sensor's surface, the Snow/Ice Detector closes the contacts of its internal relay to activate the snow/ice melting system. Once activated, the snow/ice melting system is locked on for 40 minutes during which time it is expected to reach its operating temperature. The sensor will then be checked every 40 minutes and the system will remain on until the sensor's surface is dry. The control has four indicator lights to show its operating status.

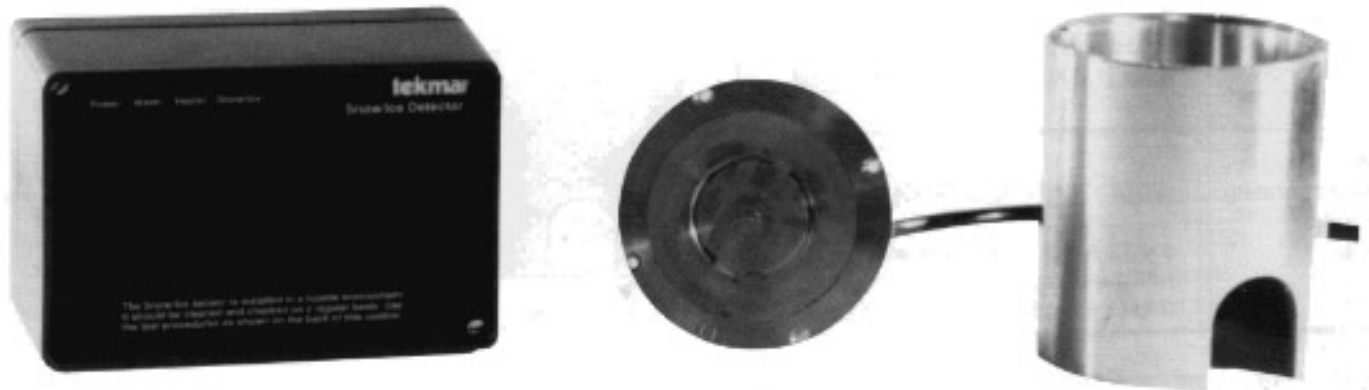

type 214 includes: 1. Electronic Control 2. Control base 3. Electronic sensor with 65 ft. (20m) cable 4. Sensor socket

Application:

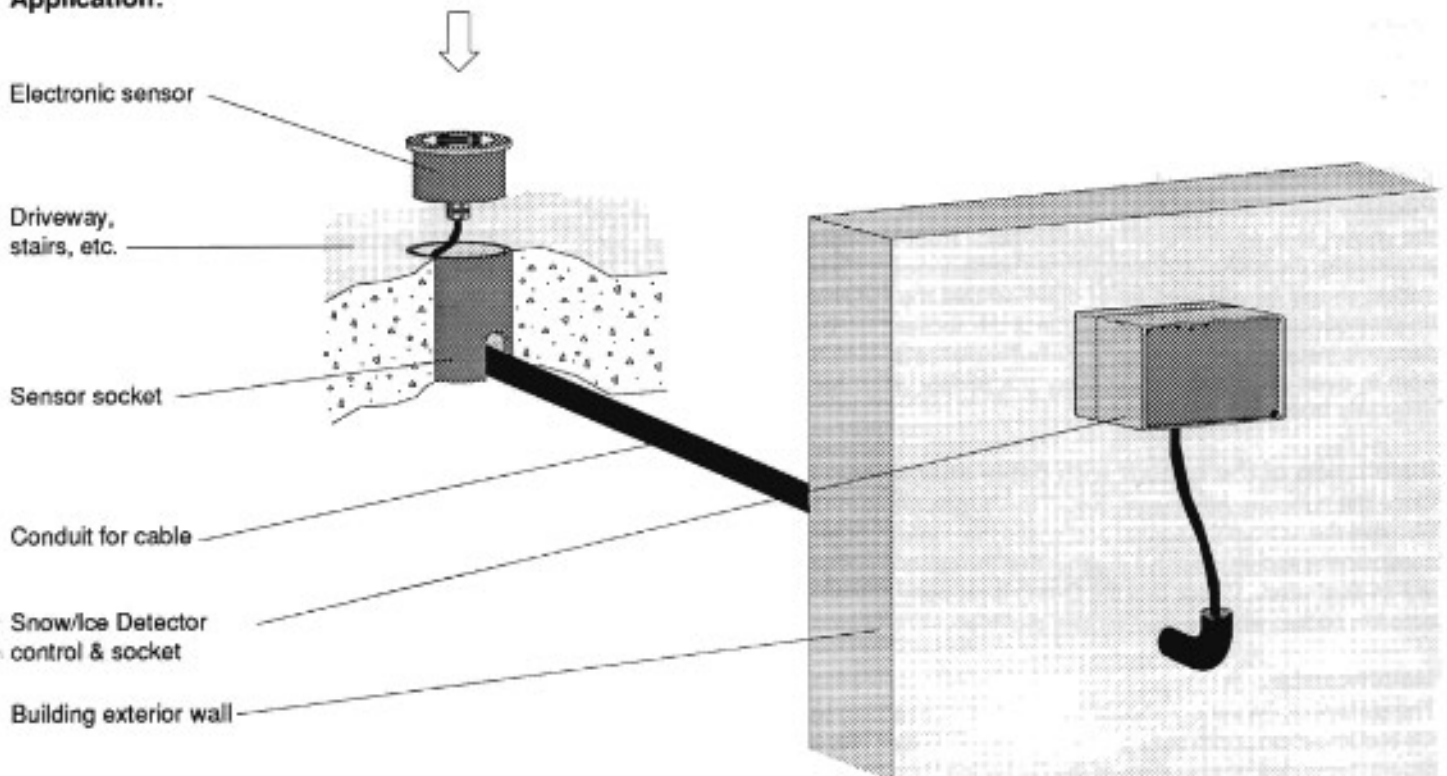

Technical Data

Control Ambient operating conditions Power supply Relay capacity Weight	30 to 120°F (0 to 50°C), < 95% RH non-condensing 24 Vac ±10%, 60 Hz, 10 VA 6A ohmic SPDT 1 lb (0.5 kg) for control with its base
Sensor Ambient operating conditions Material Weight	-20 to 150°F (-30 to 70°C) Brass and polyurethane 4 lbs (1.8 kg) for sensor with socket
Cable Ambient operating conditions Material Weight	-20 to 170°F (-30 to 80°C) 5 x 18 AWG multistrand with oil resistant polyurethane casing 3 lb (1.4 kg) for 65 feet (20 meters)

Dimensional Drawings

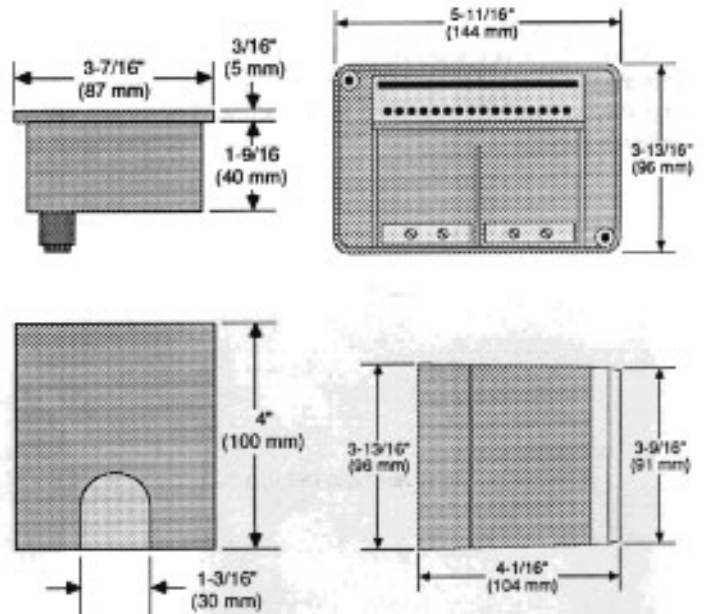

Installation

Choosing a location for the sensor

The optimal mounting location for the sensor is the location in the controlled area that is accurately representative of the surface moisture content and temperature of the controlled area. For this reason the sensor should not be located near a building's ventilation exhaust or in a sheltered location near a building, but rather in an exposed portion of the controlled area away from any buildings. Also, the sensor should not be located in dips where water collects, or in wind channels where snow and ice removal are not representative of the whole controlled area. The cable length from the sensor to a waterproof junction box must be less than 65 feet (20 m) since that is all the cable that is provided. The total cable, from sensor to control, can be as long as 500 feet (150 m).

Installation of the socket

Place the sensor's socket at the chosen location and run a conduit for the cable from the socket to a weatherproof junction box. Pour the concrete. A lid has been provided for the socket to prevent it from being accidentally filled with concrete. The socket should be adjusted up or down so that the top of the lid is flush with the finished concrete surface. The top rim of the socket must be level so that when the sensor is installed into the socket melted snow/ice doesn't run off it but evaporates from it; even on a sloping driveway the sensor must be level as the adjacent diagrams illustrate.

Installation of the sensor with cable attached

Once the concrete has cured, install the 3 inch (75mm) O-ring onto the sensor. Remove the lid from the socket and snake the cable through the conduit. Place the sensor in the socket in such a manner that the cable is not twisted, it only has a loop in it as illustrated. Check that the O-ring is properly seated then fasten the sensor onto the socket with the four screws provided.

Maintenance

The surface of the sensor should be cleaned on a regular basis in order to prevent the accumulation of dirt, salty grime, etc. from inhibiting proper water detection. The proper sequence of operation of the Snow/Ice Detector is described on page 4.

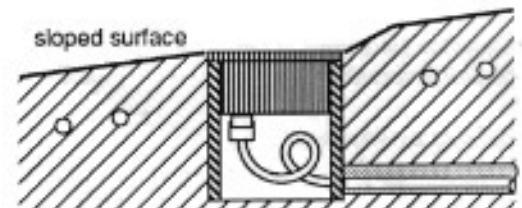
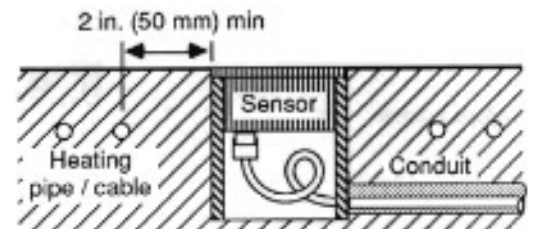
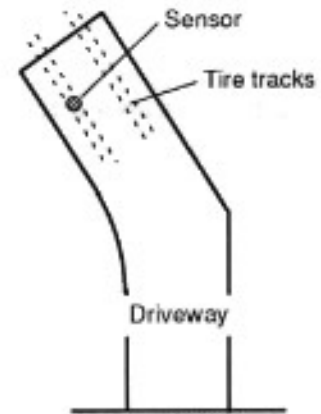

Electrical Installation

The tekmar Snow/Ice Detector terminates the wires in a plug-in socket; no wires are directly connected to the control. This plug-in system simplifies installation and troubleshooting procedures. Terminals L & N (15 & 16) of the base must be connected to the secondary side of a 24 Vac class 2 transformer. The total load of the Snow/Ice Detector is approximately 10 VA.

Note: For proper operation of the snow/ice detector, the voltage between the sensor and EARTH GROUND must be minimized and under no circumstances is it allowed to exceed 30 Vrms!

For this reason, only a class II transformer is suitable as the power supply.

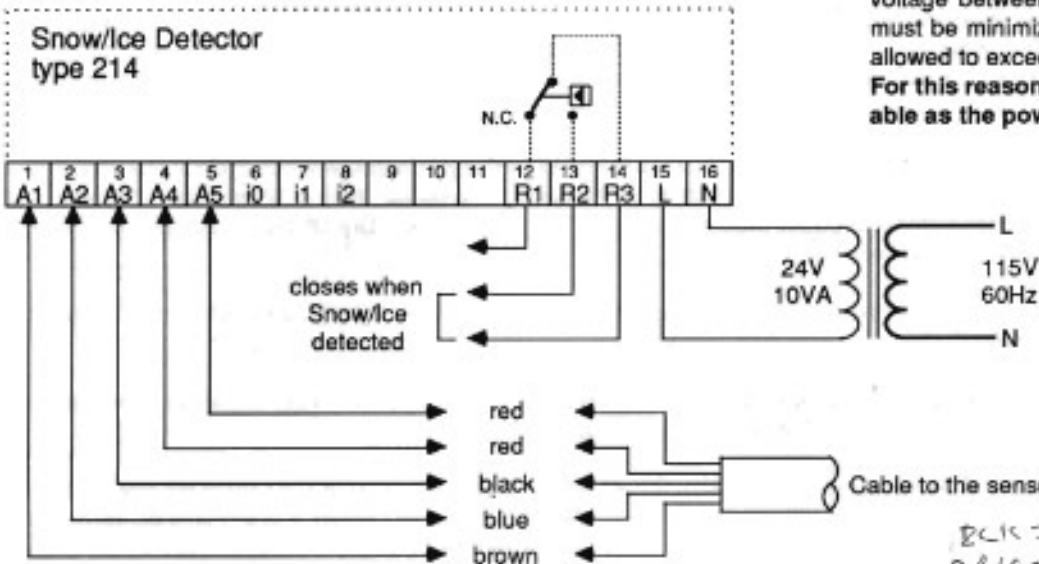

*BLK = water
BRN = GROUND = 0 volts
BLUE = - VOLTS
RED = Sensor LEADS → heat*

Adjustments

There is a danger of ice formation whenever sufficient moisture is present and when the driveway surface is cooler than 32 to 45°F (0 to 8°C). The actual temperature of ice formation depends on the construction and exposure of the travelled surface and current weather conditions. For this reason, on the back of the electronic control there is a temperature adjustment of 32 to 45°F (0 to 8°C). When sufficient moisture is present then an indicator lamp lights on the electronic control, however the relay will not switch on until the road surface is cooler than what the temperature adjustment on the electronic control is set at. Once the relay is turned on it will remain on for 40 minutes, after which the control will, for 3 minutes, check for snow/ice conditions. Depending on the outcome of this 3 minute check, the relay is turned on again for 40 minutes, or shut off after an additional 2 minutes.

Power supply 24 Vac 60Hz 10VA
Relay capacity 24 Vac 4 A ohmic

Test procedure for the sensor

Warm weather conditions:

- Using cold water, wash and cool the sensor surface. The sensor must be cooled below 100°F (40°C) for this test to work.
- Plug in the control. The "Water" light should turn on within 3 minutes and cycle off within 5 minutes.
- Unplug the control and install the supplied 100Ω resistor between terminals labelled A4 and A5 (the red wires remain connected).
- Plug in the control. The "Snow/Ice" light and relay should turn on within 3 minutes.
- Unplug the control and remove the 100Ω resistor (store the resistor in a safe place). Plug in the control.

Freezing weather conditions:

- Place snow or ice on the sensor, then plug in the control.
- The "Heater" light should turn on within 3 minutes. Soon after the "Heater" light turns on the "Snow/Ice" light should turn on and the "Heater" light turn off.

40°F (4.0°C)
32 (0) 45 (8.0)
Setpoint

H1129

Back of the control showing the 'Setpoint' adjustment

Testing

Testing

1. Unplug the control from its socket. Turn on power to the transformer. With an AC voltmeter check that 24 Vac (22 - 28 Vac) is present between terminals 15 (L) and 16 (N) of the control socket. Shorting terminals 13 (R2) and 14 (R3) will turn on the snow/ice melting system. Plug the electronic control into the socket. The "Power" light must turn on.
2. With a high impedance AC voltmeter, measure the voltage between each of the brass strips on the installed sensor and the brass socket installed in the travelled surface. The voltage must not exceed 30 Vrms. If it does, ensure that a class 2 transformer is being used to power the snow/ice detector. If a class 2 transformer is being used, then check that the Snow/Ice Detector is the only load on the transformer.
3. The control polls the sensor 3 minutes ON, 2 minutes OFF, therefore the lights "Water" and "Heater" will also cycle in this way. When the sensor is dry and the temperature of the sensor is above the setting on the back of the control, then only the "Power" light should be on. Pour some water onto the sensor surface, to cause the indicator light "Water" to turn on. Dry off the sensor surface. When it is completely dry the indicator light "Water" will turn off.
4. When the temperature of the sensor falls below the setting on the back of the control, then the light "Heater" will turn on to indicate that the sensor is heating itself to melt possible snow/ice. This light will cycle according to the heating needs of the sensor.
5. If the sensor temperature is allowed to decrease below the setting on the back of the control and the sensor is caused to be wet, then the light "Snow/Ice" and the internal relay will turn on. The lights "Water" and "Heater" will simultaneously turn off.
6. The relay is locked on for 40 minutes and the sensor is ignored. After this 40 minute slab heating cycle, the sensor will again become active and function as in steps 3 & 4 above, but the light "Snow/Ice" and the internal relay will remain on. If at any time during the next 3 minutes the sensor detects snow/ice conditions, then the control will repeat step 6, otherwise after a further 2 minute delay the relay will be turned off. In total the control keeps the snowmelting system on for at least 45 minutes.

Troubleshooting

Follow the procedure given on the back label of the control.

If the sensor is always indicating a wet condition (i.e. the light "Water" is on) then check that the sensor surface is free from contaminants such as salty grime, leaves, etc., and that the common mode voltage has not been exceeded. (See item 2 in the above testing procedure).

Limited Warranty

tekmar Control Systems (tekmar®) warrants to the original purchaser each tekmar product against defects in workmanship and materials when the product is installed by a qualified person and used in compliance with tekmar's instructions. This warranty covers the cost of parts and labor provided by tekmar to correct defects in materials and/or workmanship, but does not cover parts or labor to remove, transport or reinstall the defective product. tekmar will not be liable for any damage other than repair or replacement of the defective part or parts and such repair or replacement shall be deemed to be the sole remedy from tekmar. This warranty shall not apply to any defects caused or repairs required as a result of unreasonable or negligent use, neglect, accident, improper installation, or unauthorized repair or alterations.

In case of defect, malfunction or failure to conform to warranty, tekmar Control Systems will, for 24 months from the date of invoice or for 12 months from the date of installation of the product, whichever occurs first, repair or exchange, at tekmar's option, the defective product. The warranty is not in effect until the warranty card has been filled out and returned to tekmar Control Systems. Any express or implied

warranty which the purchaser may have, including merchantability and fitness for a particular purpose, shall not extend beyond 24 months from the date of invoice or 12 months from the date of installation, whichever occurs first.

Warranty Procedure

The installer or other qualified service person must, at the owner's expense, determine which component has failed. If an actuating motor, electronic control, mixing valve, sensor, or other tekmar component requires repair, only that component, together with the proof of purchase of the tekmar equipment must be returned to the original purchaser who in turn returns the component to tekmar after receiving a Return Goods Authorization (RGA) number from tekmar. In order to process any warranty claim, the type number and fabrication number of the product, description of the problem, and return name and address must be included with the defective component or product.

In North America:	tekmar Control Systems Ltd., Canada tekmar Control Systems Inc., USA Office: 4611 - 23rd Street Vernon, B.C. CANADA V1T 4K7 Tel.: (604) 545-7749 Fax.: (604) 545-0650
In Europe:	tekmar Angewandte Elektronik GmbH Dückerstraße 4 D-4300 Essen 16, WEST GERMANY Tel.: (0201) 49841 Fax.: (0201) 492258