

Setback RTU 308

The Setback Room Temperature Unit (RTU) type 308 is compatible with all tekmar controls having type numbers from 228 to 245 and type numbers 251, 252 and 354.

Whenever solar radiation, a fireplace, or any other heat source causes the room temperature to increase, the RTU causes the electronic control to immediately decrease the amount of heat supplied by the heating system. The RTU also forces the electronic control to overdrive the heating system for a short interval during heat-up from setback to normal room temperature. This action reduces the time required to restore normal room temperature.

For mounting instructions, see Data brochure D001. Outside dimensions are 4-1/2" H x 2-3/4" W x 7/8" D, (114 H x 70 W x 22 D mm). The built-in, self-charging battery will provide up to 1.5 hours of backup in the event of a power failure.

| Feature | with controls 251, 252, 354 | with reset controls 228 - 245 | with zone control 240 |
|-------------------------------|-----------------------------|-------------------------------|-------------------------|
| Normal (day) adjustment range | 61 to 75°F (16 to 24°C) | 61 to 75°F (16 to 24°C) | 59 to 79°F (15 to 25°C) |
| Setback adjustment range | 0 to 12°F (0 to 7°C) | 0 to 12°F (0 to 7°C) | 0 to 18°F (0 to 10°C) |

Installation

- The RTU is normally installed on an interior wall of the main living area of the building. Do not mount the RTU near a heat source (e.g. sunlight through a window, a fireplace, etc.) or in a drafty area (e.g. near an exterior door or a window) unless the sensor element is mounted remotely in a suitable location.
- Remove the front of the RTU by pulling at its top and bottom. Mount the RTU base to the wall or an electrical box using two screws.
- Connect two wires to the RTU terminals labelled "RT RT". Connect the other end of the wires to the appropriate terminals on the tekmar heating system controls' socket. (See the Data brochure of the particular control you are using).
- Set the selector switch in the RTU to "INT" or "EXT".
 - "INT" means that the digital setback timer will enable the ☾ dial (setback dial) during setback, and adjusting this dial will affect the amount of setback there is.
 - "EXT" means that the ☾ dial is disabled and a wire connected from the RTU terminal "Ti" to the appropriate terminal in the socket of the tekmar reset or zone control will cause the tekmar control to enter its own internal setback.
- Re-install the cover of the RTU. Set the ☼ dial to the 68°F (20°C) setting, and the ☾ dial to its mid-range setting.

Options

- If a remote sensor is desired, away from the RTU's location, then remove the small disc shaped sensor from the RTU at the terminals labelled "Sensor", and install the remote sensor here. (types 313, 317, 318, 321 or 324)
- If this RTU is to be used as only a setback timer for a tekmar reset control, then in place of the internal RTU disc shaped sensor, install the 2430Ω resistor from the reset control and follow the procedure for "EXT" operation. The ☼ dial must be kept in its 68°F (20°C) position.

Programming the Clock of RTU type 308

- When this RTU is first powered up, the clock's internal battery needs to be charged and therefore there will be no display for 5-10 minutes. When the display appears, proceed to program the clock. This setback clock is capable of up to three different day/setback cycles per day. These times can be the same every day of the week (24 hr schedule), or can be different every day of the week (7-day schedule).

Notes

- If the "hour" or "min." button is held for more than 1 second during programming, the displayed time will advance quickly.
- If there is no keypad activity for 40 seconds, program mode is abandoned.
- The terms "setback" and "Daymode OFF" are interchangeable.

1) To reset the clock and clear all programmed information

- Press at the same time "day", ☾, "min." and ✎ buttons, then release.

2) To set time and date

- Press and hold ☾
- Press "day" then "hour" then "min." to program the correct time. Release ☾.

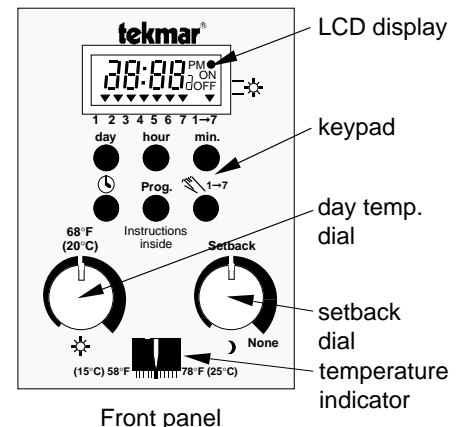
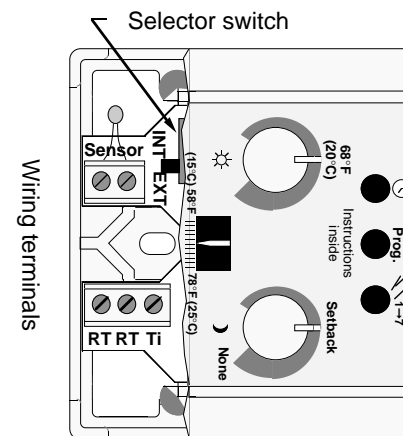

3) To program a 24-hour schedule for every day of the week

- Press "Prog." once and release. Press once and release.
- Set the time for the start of the Day mode pressing "hour" and "min." buttons only.
- Press "Prog." once and release. Press once and release.
- Set the time for the end of the Day mode pressing "hour" and "min." buttons only.
- If 2nd and 3rd cycles are desired, repeat procedure 3. When finished, press .

If this program needs to be changed, reset the clock and do procedures 2 & 3.

4) To program a 7-day schedule for every day of the week

- Press "Prog." once and release.
- Set the day to be programmed by pressing "day" only (1= Sunday).
- Set the time for start of the Day mode by pressing "hour" and "min." buttons.
- Press "Prog." once and release.
- Set the time for end of the Day mode by pressing "hour" and "min." buttons.
- If 2nd and 3rd cycles within the same day are desired, press and release "Prog." and repeat the preceding 3 steps.
- Continue repeating procedure 4 until all the days of the week are programmed.
- When finished, press . The programming is now complete.

If this program needs to be changed, review the program and press "hour" or "min." to change the times.

- To delete any programmed time, review the program to the day and cycle requiring deletion and press together "hour" and "min." buttons.

5) Program review

- To review the program, repeatedly press and release "Prog."

6) Manual Override

- For **temporary (single event) override**, press . To disable temporary override, press again.
- For **permanent (holiday) override**, press and hold and then repeatedly press and release "min." until the desired state of permanent override is obtained as shown in the adjacent table. Release . To disable permanent override press and hold and press and release "min." until the dot disappears.

7) Quick change to daylight savings or standard time

- To subtract 1 hour from the clock (in the fall), press "day" and "min." together.
- To add 1 hour to the clock (in the spring), press "day" and "hour" together.

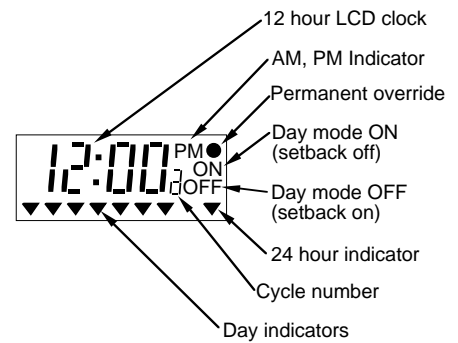

LCD clock description

| Displayed state | Type of permanent override achieved |
|-----------------|-------------------------------------|
| | No override |
| | Day mode ON override |
| | Day mode OFF override |

Permanent override types possible

Limited Warranty and Product Return Procedure

Limited Warranty: tekmar warrants to the original purchaser each tekmar product against defects in workmanship and materials when the product is installed and used in compliance with tekmar's instructions. This limited warranty covers the cost of parts and labour provided by tekmar to correct defects in materials and/or workmanship. Returned products that are fully operational are not considered a warranty case. tekmar also does not cover parts or labour to remove, transport or reinstall a defective product. tekmar will not be liable for any damage other than repair or replacement of the defective part or parts and such repair or replacement shall be deemed to be the sole remedy from tekmar. This warranty shall not apply to any defects caused or repairs required as a result of unreasonable or negligent use, neglect, accident, improper installation, or unauthorized repair or alterations. In case of defect, malfunction or failure to conform to warranty, tekmar will, for a warranty period of 24 months from the date of invoice to the original purchaser or 12 months from the date of installation of the product, whichever occurs first, repair, exchange or give credit for the defective product. Any express or implied warranty which the purchaser may have, including merchantability and fitness for a particular purpose, shall not extend beyond 24 months from the date of invoice or 12 months from the date of installation of the product, whichever occurs first.

Replacements: tekmar can send replacement products if requested. All replacements are invoiced. Any possible credit for the replacement will only be issued once the replaced product has been returned to tekmar.

Product Return Procedure: Products that are believed to have failed must be returned to tekmar Control Systems Ltd. 4611-23rd Street, Vernon B.C. Canada V1T 4K7 when agreed to by tekmar. The installer or other qualified service person must, at the owner's expense, determine which component has failed. The product must be returned complete with

all of its components (sensors, base, etc.). Products must be returned together with the proof of purchase to the original purchaser who then returns the product to tekmar after receiving a Return Goods Authorization (RGA) number from tekmar.

Please include the following information with the product. The full address of the original purchaser, the RGA number and a description of the problem.

From the U.S.A., in order to avoid customs charges, products must be returned via US Post with the package clearly marked with the RGA number, product type and the statement "Canadian Product returned for repair". For shipping purposes the product can be valued at one half list price.

- 1) If returned during the warranty period and the product is defective, tekmar will issue full credit for the returned product less cost of missing parts.
- 2) If returned during the warranty period and the product is fully operational, tekmar will return the product to the original purchaser for a testing cost of \$30.00 plus postage.
- 3) If returned during the warranty period and the product is not damaged and is fully operational, tekmar can take back the product for a return charge of 40% of the product's net value. This request has to be specified otherwise the product will be returned with a testing cost of \$30.00 plus postage.
- 4) If returned after the warranty period and the product needs repair, tekmar will repair and return the product. Repair and postage costs will be invoiced. tekmar's repair costs are calculated at \$30.00 / hour plus the cost of parts. If the repair costs will be more than \$60.00 a repair estimate will be sent to the original purchaser.

In North America: tekmar Control Systems Ltd., Canada
tekmar Control Systems, Inc., U.S.A.
Head Office: 4611 - 23rd Street
Vernon, B.C. Canada V1T 4K7
Tel. (604) 545-7749 Fax. (604) 545-0650