

# tekmar® - Application

Snow Detector & Melting Control 661

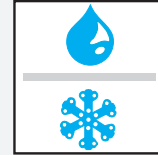

A 661-1

11/94

## Mechanical

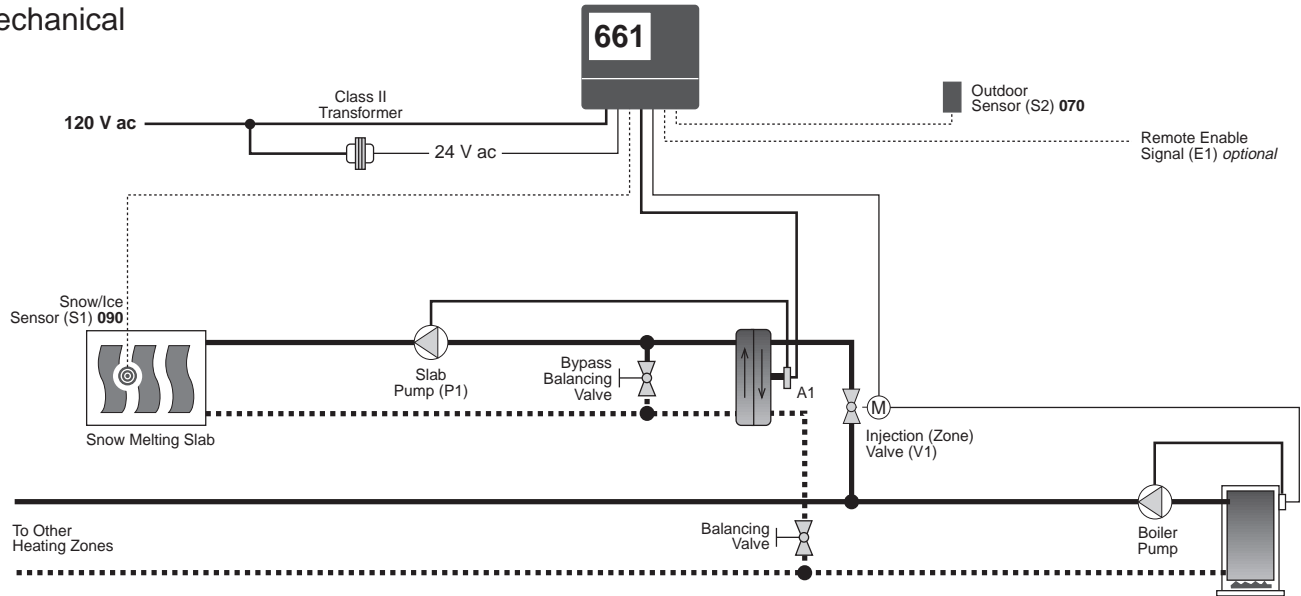

## Electrical

- A1 = Freeze Protection Aquastat (Break on fall)
- E1 = Remote Enable Signal *optional*
- P1 = Slab Pump
- S1 = Snow/Ice Sensor 090
- S2 = Outdoor Sensor 070
- V1 = Injection (Zone) Valve Motor

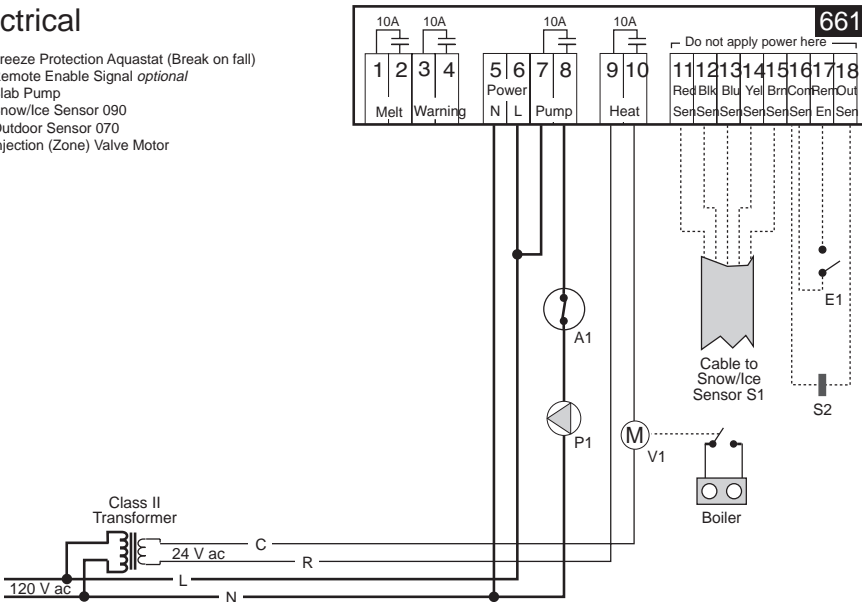

**Note:** This is only a concept drawing. The designer must determine whether this application will work in his system and must ensure compliance with code requirements. Necessary auxiliary equipment, isolation relays (for loads greater than the specified tekmar internal relay ratings), and other safety and limit devices must be added.

**Snow Detector & Melting Control 661**

- Literature — D 661, A 661, D 001, D 090, E 000, E 600
- Control — Microprocessor PI control; This is **not a safety (limit) control**.
- Packaged weight — 3.4 lb. (1550 g), Enclosure A, PVC plastic
- Dimensions — 6-5/8" H x 7-9/16" W x 2-13/16" D (170 x 193 x 72 mm)
- Approvals — CSA NRTL/C, meets DOC regulations for EMI/RFI.
- Ambient conditions — Indoor use only, 30 to 105°F (0 to 40°C), < 90% RH non-condensing.
- Power supply — 120 V ac ±10% 50/60 Hz 20 VA
- Relays — 120 V ac 10 A 1/3 hp, pilot duty 240 VA 2 A
- Sensors included: — NTC thermistor, 10 kΩ @ 25°C ±0.2°C β=3892  
Outdoor Sensor 070.
- Sensors required: — Snow/Ice Sensor 090 and Sensor Socket 091. (Order separately)
- Control accuracy — ±1°F (±0.5°C) with up to 500 feet (150m) of 18 AWG wire to sensors.
- Detection of Snow/Ice — Down to -20°F (-29°C) in calm air with 500 feet (150M) of 18 AWG wire to Snow/Ice Sensor 090.
- Surface, Melting — 34 to 44°F (1 to 7°C)
- Surface, Idling — Off, 24 to 35°F (-5 to 2°C)
- Water Sensitivity — 20 to 80%
- Minimum On Time — Off, 0.2 to 4 hours
- CWCO — Off, -22 to 25°F (-30 to -4°C)

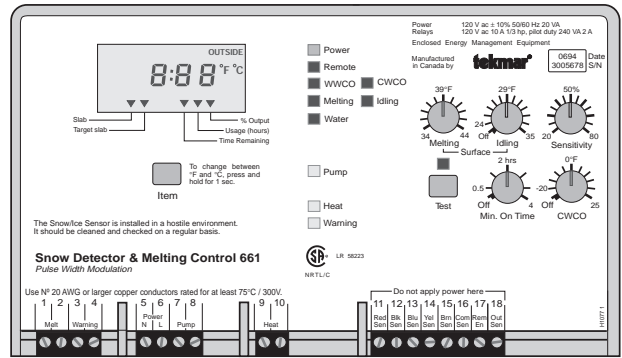

**System Operation & Specifications**

The tekmar Snow Detector and Melting Control 661 applies heat to the slab when a signal is received from the Snow/Ice Sensor 090. The 661 control pulse width modulates (PWM) the injection (zone) valve to maintain a slab temperature as set by the "Idling" or "Melting" surface temperature dials. The slab pump is automatically turned off when Warm Weather Cut Off (WWCO) or Cold Weather Cut Off (CWCO) occurs or the freeze protection aquastat operates.

**The control shall meet the technical specifications given above and shall provide the following functions.**

- The snow melting system shall be part of a larger hydronic heating system that protects the boiler from thermal shock by mixing snow melting system return water with a large amount of warmer heating system return water.
- The bypass valve in the snow melting loop provides a method to balance flows so that the heat exchanger will operate above 35°F (2°C).
- The control shall vary the operating time (PWM) of an injection (zone) valve to maintain the slab at the required temperature.
- The detection of snow/ice shall be determined by the snow/ice sensor surface temperature and surface moisture level.
- The snow/ice sensor shall be mounted into a socket flush with the slab surface.
- On detection of snow/ice, the control shall begin operation from either an "Off" mode (no heat to slab) or an "Idling" mode (slab operated at an "Idling" temperature) to a snow "Melting" mode (slab operated at a "Melting" temperature).
- The control shall prevent snow melting when the outdoor temperature is colder than the selected CWCO dial setting.
- WWCO shall occur when the outdoor temperature and slab surface temperature rise above the "Melting" surface temperature dial setting.
- Both the slab pump and heat exchanger injection valve shall be turned off once the control goes into WWCO or CWCO.
- The pump shall be exercised once every three days to help prevent seizure during periods of non operation.
- The control shall display the outside, slab surface and target slab surface temperatures in °F or °C.
- The control shall have a warning output indicating a sensor or system control fault.
- The control shall have a test button which activates a preprogrammed test sequence for all control inputs and outputs.
- The control shall continuously monitor its sensors and provide an LCD error message if a sensor is short or open circuit.
- The installer must ensure that the control and its wiring are isolated and/or shielded from strong sources of electromagnetic noise.
- **Order the following tekmar products for this application:** one Snow Detector & Melting Control 661, one Snow/Ice Sensor 090 and one Snow/Ice Sensor Socket 091.

<p><b>In North America:</b></p>	<p>tekmar Control Systems Ltd., Canada                  tekmar Control Systems, Inc., U.S.A.                  Head Office: 4611 - 23rd Street                  Vernon, B.C. Canada V1T 4K7                  Tel. (604) 545-7749 Fax. (604) 545-0650</p>
---------------------------------	---

# tekmar® - Application

Snow Detector & Melting Control 661

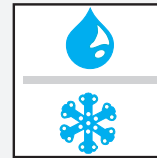

A 661-2

11/94

## Mechanical

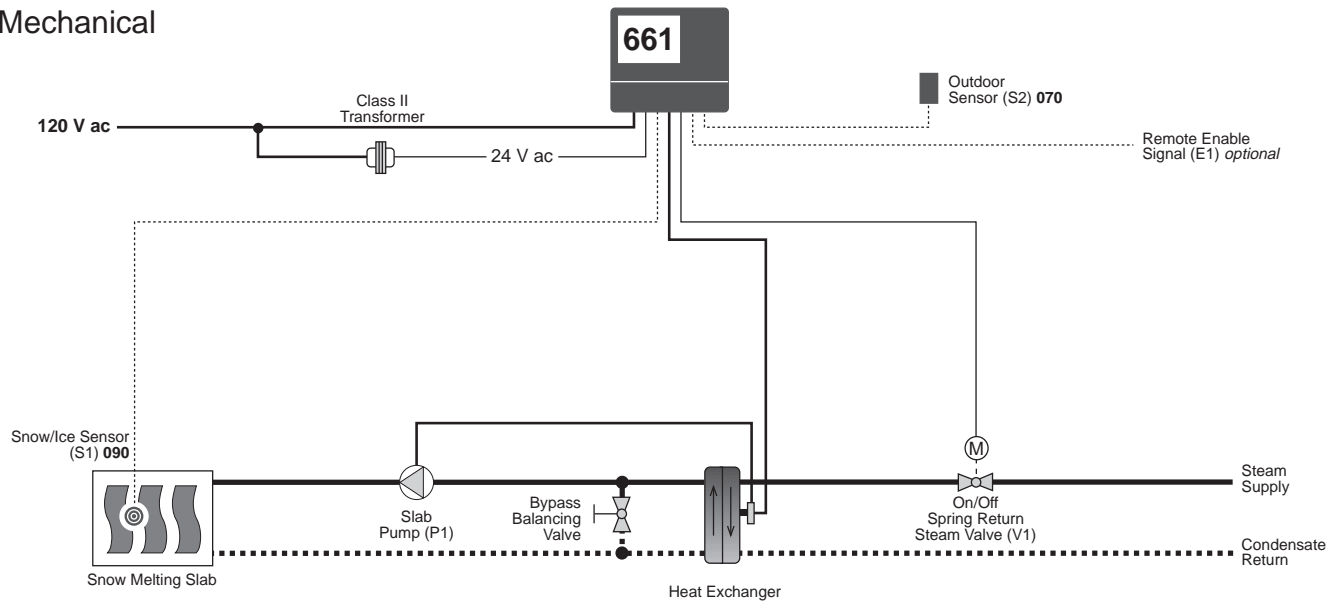

## Electrical

- A1 = Freeze Protection Aquastat (Break on fall)
- E1 = Remote Enable Signal *optional*
- P1 = Slab Pump
- S1 = Snow/Ice Sensor 090
- S2 = Outdoor Sensor 070
- V1 = On/Off Spring Return Steam Valve

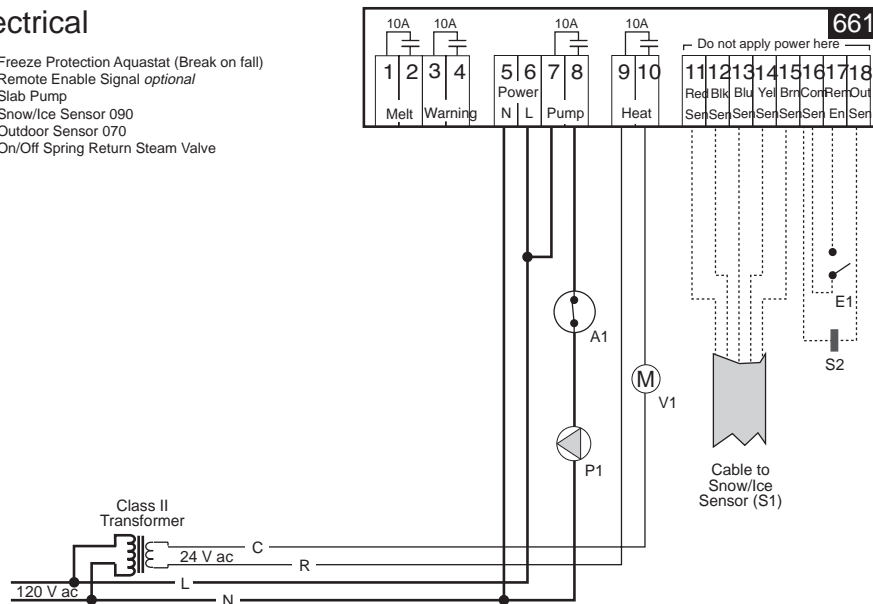

**Note:** This is only a concept drawing. The designer must determine whether this application will work in his system and must ensure compliance with code requirements. Necessary auxiliary equipment, isolation relays (for loads greater than the specified tekmar internal relay ratings), and other safety and limit devices must be added.

**Snow Detector & Melting Control 661**

- Literature — D 661, A 661, D 001, D 090, E 000, E 600
- Control — Microprocessor PI control; This is **not a safety (limit) control**.
- Packaged weight — 3.4 lb. (1550 g), Enclosure A, PVC plastic
- Dimensions — 6-5/8" H x 7-9/16" W x 2-13/16" D (170 x 193 x 72 mm)
- Approvals — CSA NRTL/C, meets DOC regulations for EMI/RFI.
- Ambient conditions — Indoor use only, 30 to 105°F (0 to 40°C), < 90% RH non-condensing.
- Power supply — 120 V ac ±10% 50/60 Hz 20 VA
- Relays — 120 V ac 10 A 1/3 hp, pilot duty 240 VA 2 A
- Sensors included: — NTC thermistor, 10 kΩ @ 25°C ±0.2°C β=3892  
Outdoor Sensor 070.
- Sensors required: — Snow/Ice Sensor 090 and Sensor Socket 091. (Order separately)
- Control accuracy — ±1°F (±0.5°C) with up to 500 feet (150m) of 18 AWG wire to sensors.
- Detection of Snow/Ice — Down to -20°F (-29°C) in calm air with 500 feet (150M) of 18 AWG wire to Snow/Ice Sensor 090.
- Surface, Melting — 34 to 44°F (1 to 7°C)
- Surface, Idling — Off, 24 to 35°F (-5 to 2°C)
- Water Sensitivity — 20 to 80%
- Minimum On Time — Off, 0.2 to 4 hours
- CWCO — Off, -22 to 25°F (-30 to -4°C)

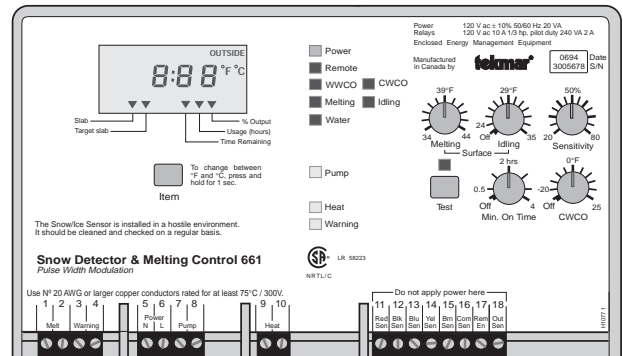

**System Operation & Specifications**

The tekmar Snow Detector and Melting Control 661 applies heat to the slab when it detects conditions that require heat. The 661 control pulse width modulates (PWM) the steam valve to maintain a slab temperature as set by the "Idling" or "Melting" surface temperature dials. The slab pump is automatically turned off when Warm Weather Cut Off (WWCO) or Cold Weather Cut Off (CWCO) occurs, or the freeze protection aquastat operates.

**The control shall meet the technical specifications given above and shall provide the following functions.**

- The bypass valve in the snow melting loop provides a method to balance flows so that the heat exchanger will operate above 35°F (2°C).
- The snow detector and melting control 661 shall PWM a spring return on-off steam valve to regulate the amount of heat injected into the slab from a steam source.
- The detection of snow/ice shall be determined by the snow/ice sensor surface temperature and surface moisture level.
- The snow/ice sensor shall be mounted into a socket, flush with the slab surface.
- On detection of snow/ice, the control shall begin operation from either an "Off" mode (no heat to slab) or an "Idling" mode (slab operated at an "Idling" temperature) to a snow "Melting" mode (slab operated at a "Melting" temperature).
- Both the slab pump and injection steam valve shall be turned off once the control goes into WWCO or CWCO.
- The control shall prevent snow melting when the outdoor temperature is colder than the selected CWCO dial setting.
- WWCO shall occur when the outdoor temperature and slab surface temperature rise above the "Melting" surface temperature dial setting.
- The slab pump shall be exercised once every three days to help prevent seizure during periods of non operation.
- The control shall display the outside, slab surface, and target slab surface temperatures in °F or °C.
- The control shall have a warning output indicating a sensor or system control fault.
- The control shall have a test button which activates a preprogrammed test sequence for all control inputs and outputs.
- The control shall continuously monitor its sensors and provide an LCD error message if a sensor is short or open circuit.
- The installer must ensure that the control and its wiring are isolated and/or shielded from strong sources of electromagnetic noise.
- **Order the following tekmar products for this application:** one Snow Detector & Melting Control 661, one Snow/Ice Sensor 090, and one Snow/Ice Sensor Socket 091.

<b>In North America:</b>	tekmar Control Systems Ltd., Canada tekmar Control Systems, Inc., U.S.A. Head Office: 4611 - 23rd Street Vernon, B.C. Canada V1T 4K7 Tel. (604) 545-7749 Fax. (604) 545-0650
--------------------------	--

# tekmar® - Application

Snow Detector & Melting Control 661

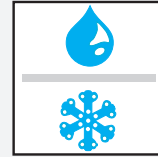

A 661-3

11/94

## Mechanical

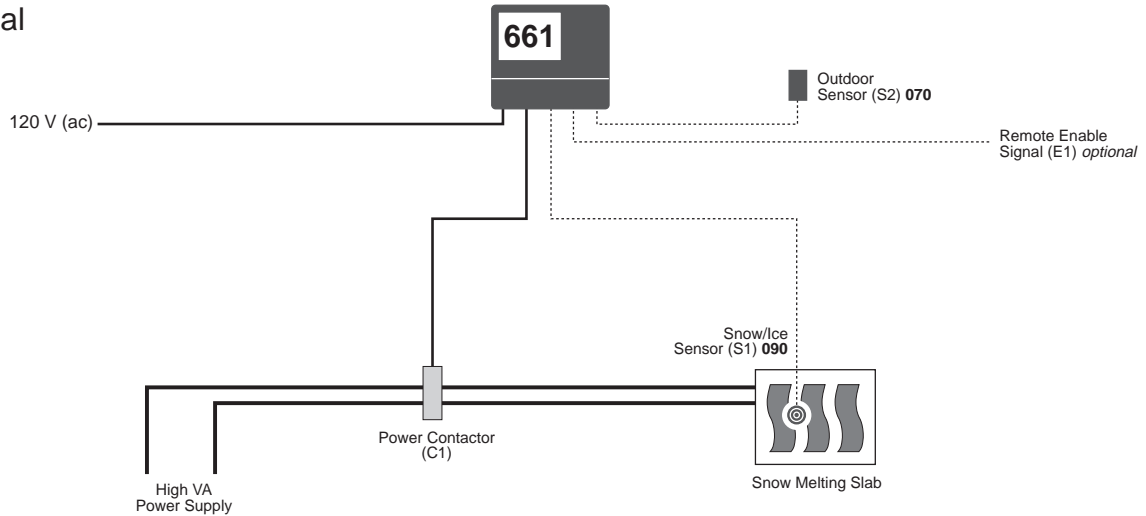

## Electrical

C1 = Power Contactor  
 E1 = Remote Enable Signal (E1) optional  
 S1 = Snow/Ice Sensor 090  
 S2 = Outdoor Sensor 070

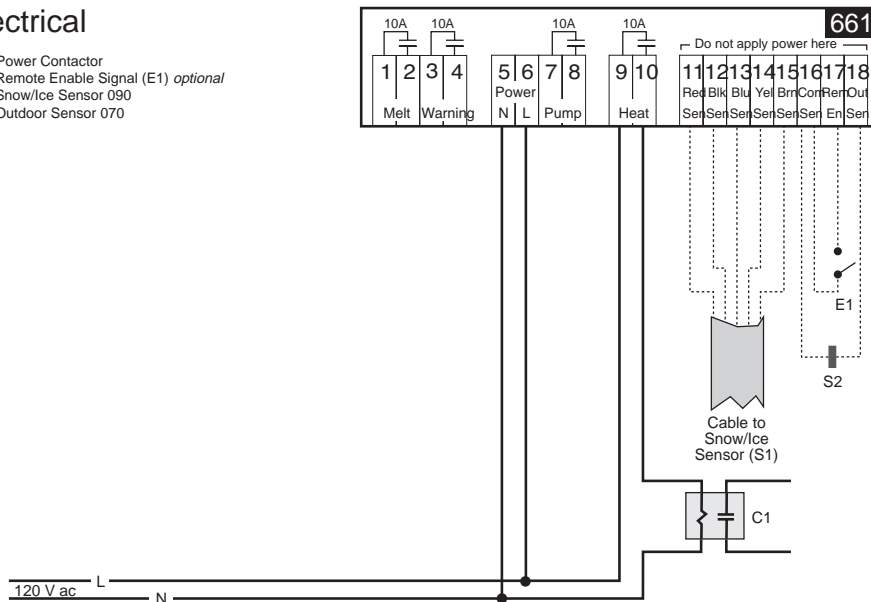

**Note:** This is only a concept drawing. The designer must determine whether this application will work in his system and must ensure compliance with code requirements. Necessary auxiliary equipment, isolation relays (for loads greater than the specified tekmar internal relay ratings), and other safety and limit devices must be added.

## Snow Detector & Melting Control 661

Literature	— D 661, A 661, D 001, D 090, E 000, E 600
Control	— Microprocessor PI control; This is <b>not a safety (limit) control</b> .
Packaged weight	— 3.4 lb. (1550 g), Enclosure A, PVC plastic
Dimensions	— 6-5/8" H x 7-9/16" W x 2-13/16" D (170 x 193 x 72 mm)
Approvals	— CSA NRTL/C, meets DOC regulations for EMI/RFI.
Ambient conditions	— Indoor use only, 30 to 105°F (0 to 40°C), < 90% RH non-condensing.
Power supply	— 120 V ac ±10% 50/60 Hz 20 VA
Relays	— 120 V ac 10 A 1/3 hp, pilot duty 240 VA 2 A
Sensors	— NTC thermistor, 10 kΩ @ 25°C ±0.2°C β=3892
included:	Outdoor Sensor 070.
required:	Snow/Ice Sensor 090 and Sensor Socket 091. (Order separately)
Control accuracy	— ±1°F (±0.5°C) with up to 500 feet (150m) of 18 AWG wire to sensors.
Detection of Snow/Ice	— Down to -20°F (-29°C) in calm air with 500 feet (150M) of 18 AWG wire to Snow/Ice Sensor 090.
Surface, Melting	— 34 to 44°F (1 to 7°C)
Surface, Idling	— Off, 24 to 35°F (-5 to 2°C)
Water Sensitivity	— 20 to 80%
Minimum On Time	— Off, 0.2 to 4 hours
CWCO	— Off, -22 to 25°F (-30 to -4°C)

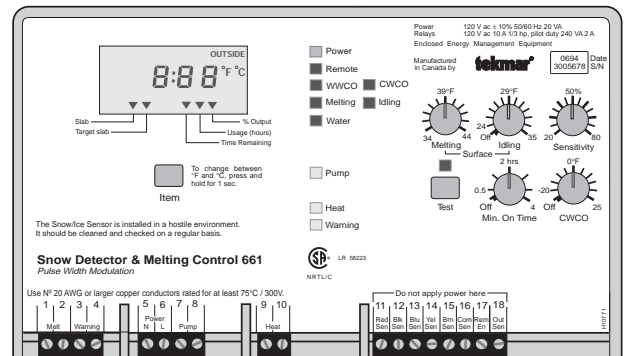

## System Operation & Specifications

The tekmar Snow Detector and Melting Control 661 applies heat to the slab when it detects conditions that require heat. The 661 control pulse width modulates (PWM) the electric cables to maintain a slab temperature as set by the "Idling" or "Melting" surface temperature dials. The electric cables are automatically turned off when Warm Weather Cut Off (WWCO) or Cold Weather Cut Off (CWCO) occurs.

**The control shall meet the technical specifications given above and shall provide the following functions.**

- The snow detector and melting control 661 shall PWM a power contactor to regulate the amount of heat applied to the slab by the electric cables.
- The detection of snow/ice shall be determined by the snow/ice sensor surface temperature and surface moisture level.
- The snow/ice sensor shall be mounted into a socket, flush with the slab surface, for easy replacement.
- On detection of snow/ice, the control shall begin operation from either an "Off" mode (no heat to slab) or an "Idling" mode (slab operated at an "Idling" temperature) to a snow "Melting" mode (slab operated at a "Melting" temperature).
- WWCO shall occur when the outdoor temperature and slab surface temperature rise above the "Melting" surface temperature dial setting.
- CWCO shall occur when the outdoor temperature falls below the "CWCO" dial setting.
- The control will not heat the slab during WWCO or CWCO.
- The control shall display the outside, slab surface, and target slab surface temperatures in °F or °C.
- The control shall have a warning output indicating a sensor or system control fault.
- The control shall have a test button which activates a preprogrammed test sequence for all control inputs and outputs.
- The control shall continuously monitor it's sensors and provide an LCD error message if a sensor is short or open circuit.
- The installer must ensure that the control and its wiring are isolated and/or shielded from strong sources of electromagnetic noise.
- **Order the following tekmar products for this application:** one Snow Detector & Melting Control 661, one Snow/Ice Sensor 090 and one Snow/Ice Sensor Socket 091

<b>In North America:</b>	tekmar Control Systems Ltd., Canada tekmar Control Systems, Inc., U.S.A. Head Office: 4611 - 23rd Street Vernon, B.C. Canada V1T 4K7 Tel. (604) 545-7749 Fax. (604) 545-0650
--------------------------	--

# Mechanical

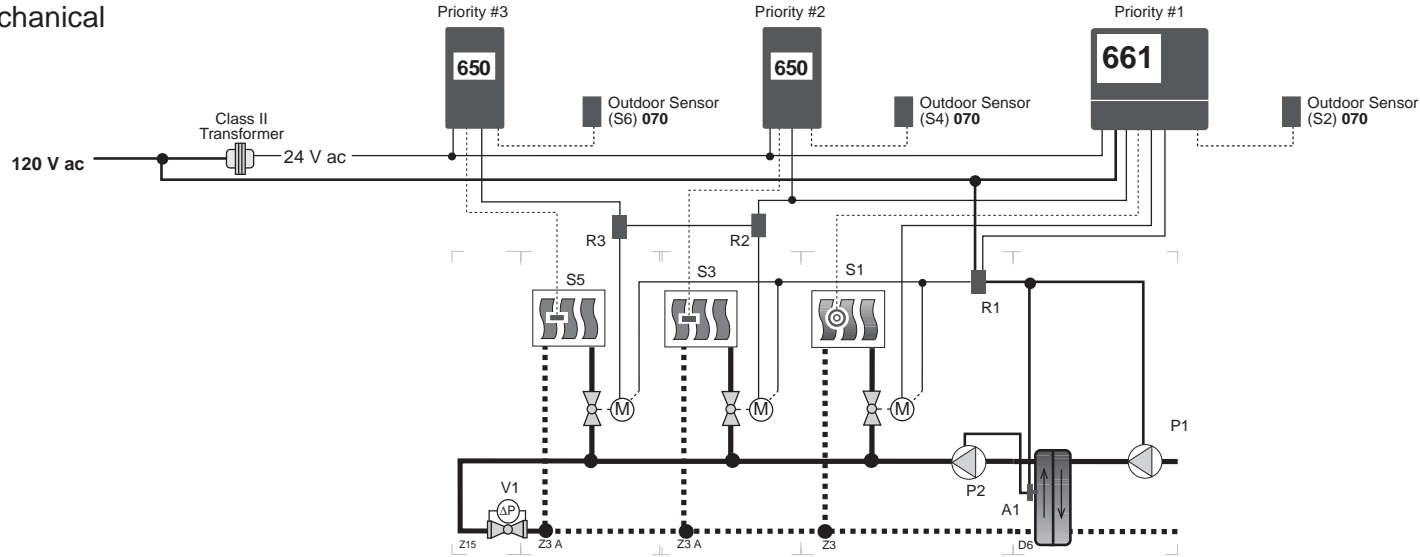

# Electrical

- A1 = Freeze Protection Aquastat (Break on fall)
- E1 = Remote Enable
- P1 = Primary Pump
- P2 = System Pump
- R1, R2, R3 = Relay 003
- S2, S4, S6 = Outdoor Sensor 070
- S1 = Snow / Ice Sensor 090, Socket 091
- S3, S5 = Slab Sensor 072
- V1 = Pressure Bypass Valve, Balancing Valve, or Globe Valve

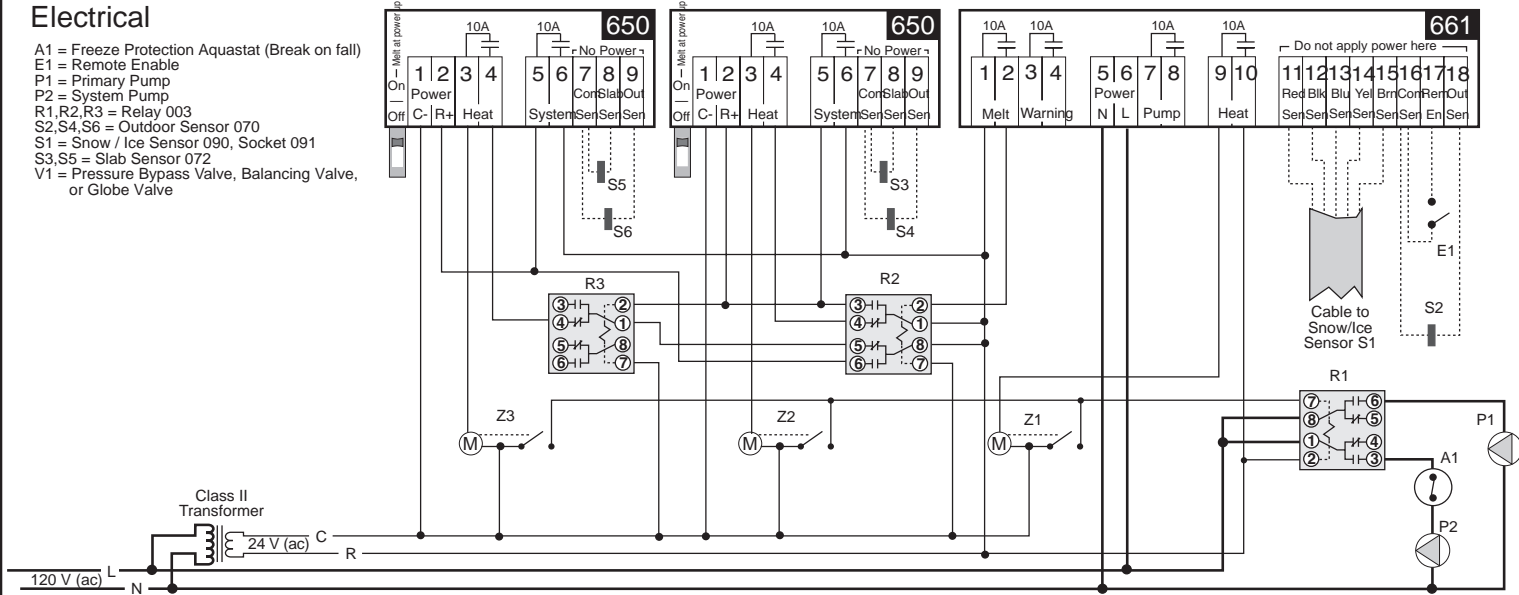

**Note:** This is only a concept drawing. The designer must determine whether this application will work in his system and must ensure compliance with code requirements. Necessary auxiliary equipment, isolation relays (for loads greater than the specified tekmar internal relay ratings), and other safety and limit devices must be added.

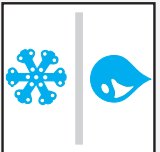

**Technical Data**

**Snow Detector & Melting Control 661 Pulse Width Modulation**

- Literature — A 000, A 661's, D 661, D 001, D 070, D 090
- Control — Microprocessor PI control; This is **not a safety (limit) control**.
- Packaged weight — 3.4 lb. (1550 g), Enclosure A, modified PPO plastic.
- Dimensions — 6-5/8" H x 7-9/16" W x 2-13/16" D (170 x 193 x 72 mm)
- Approvals — CSA NRTL/C, meets ICES & FCC regulations for EMI/RFI.
- Ambient conditions — Indoor use only, 32 to 105°F (0 to 40°C), < 90% RH non-condensing.
- Power supply — 120 V ±10% 50/60 Hz 20 VA
- Relays — 120 V (ac) 10 A 1/3 hp, pilot duty 240 VA 2 A
- Sensors — NTC thermistor, 10 kΩ @ 77°F (25°C ±0.2°C) β=3892  
 included: Outdoor Sensor 070.  
 required: Snow/Ice Sensor 090 and Sensor Socket 091. (Order separately)
- Detection of Snow/Ice — Down to -20°F (-29°C) in calm air with 500 feet (150 m) of 18 AWG wire to Snow/Ice Sensor 090.
- Surface, Melting — 34 to 44°F (1 to 7°C)
- Surface, Idling — Off, 24 to 35°F (Off, -5 to 2°C)
- Water Sensitivity — 20 to 80%
- Minimum On Time — Off, 0.2 to 4 hours
- CWCO — Off, -22 to 25°F (Off, -30 to -4°C)
- Temperature display — Fahrenheit / Celsius

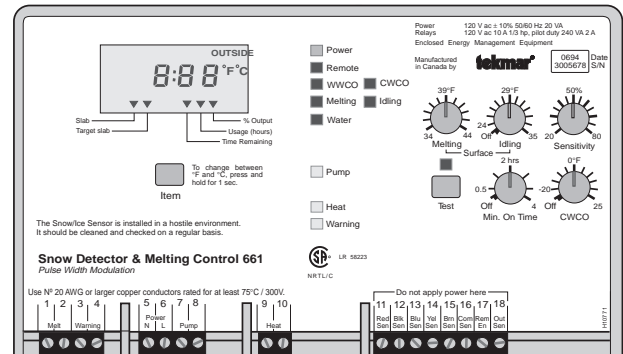

**System Operation & Specifications**

The Snow Detector and Melting Control 661 with the Snow / Ice Sensor 090 combine with two Snow Melting Control 650's to provide snow melting for three zones with different levels of priority.

**Piping and Heat Source Details** The snow melting loops are piped in a two pipe direct return method using zone valves to control the flow to each zone. A pressure bypass valve (V1) is located in the loop to provide a pressure drop between the supply and return sides of each of the zones. The heat source is isolated from the snow melting loop by a heat exchanger. Since it is the size of the heat exchanger that limits the amount of heat that can be delivered to the snow melting system, each snow melting zone should be of approximately the same size in order to prevent overheating and under-heating.

**System Operation** The 661 control is placed in the zone that has the highest priority. When the Snow / Ice Sensor 090 detects snow or ice, the 661 powers up the two 650's and begins melting in its own zone. While the 661 is in melting mode, the 650's are prevented from melting through the use of external relays. Once the 661 has finished melting, the 650 controlling zone two is allowed to operate its zone valve to provide heat to its zone. Once the first 650 has completed its snow melting cycle, the second 650 is allowed to operate its zone valve in order to provide heat to the final snow melting zone.

**Warm Weather Cut Off (WWCO)** As the outdoor temperature rises, it becomes unnecessary to snow melt. When the outdoor temperature and the slab temperature rise above the *Melting* setpoint of the controls, the snow melting is disabled.

**Cold Weather Cut Off (CWCO)** As the outdoor temperature drops, it becomes impractical or impossible to snow melt because of the amount of heat the slab requires. When the outdoor temperature drops below the *CWCO* setting, snow melting cannot be started.

**Additional Functions** Additional functions are listed in the table in the Snow Melting Controls section of the Product Catalog I 000 and the Application Catalog A 000.

*Note:* Since the 661 has priority over the 650 controls, it is possible for the 661 to interrupt the 650's during their melting cycles and potentially allow the zones controlled by the 650's to freeze up.

	tekmar Control Systems Ltd., Canada tekmar Control Systems, Inc., U.S.A. <b>Head Office: 4611 - 23rd Street</b> <b>Vernon, B.C. Canada V1T 4K7</b> <b>Tel. (250) 545-7749 Fax. (250) 545-0650</b>
---	---

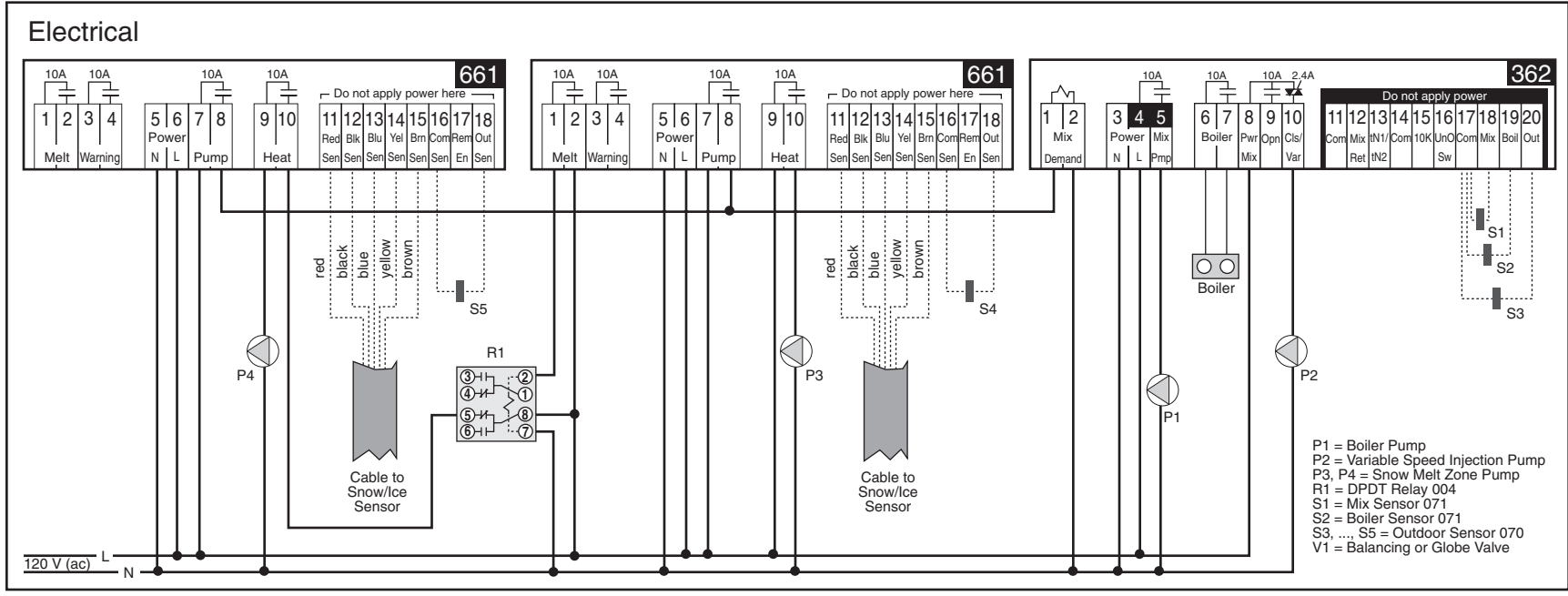
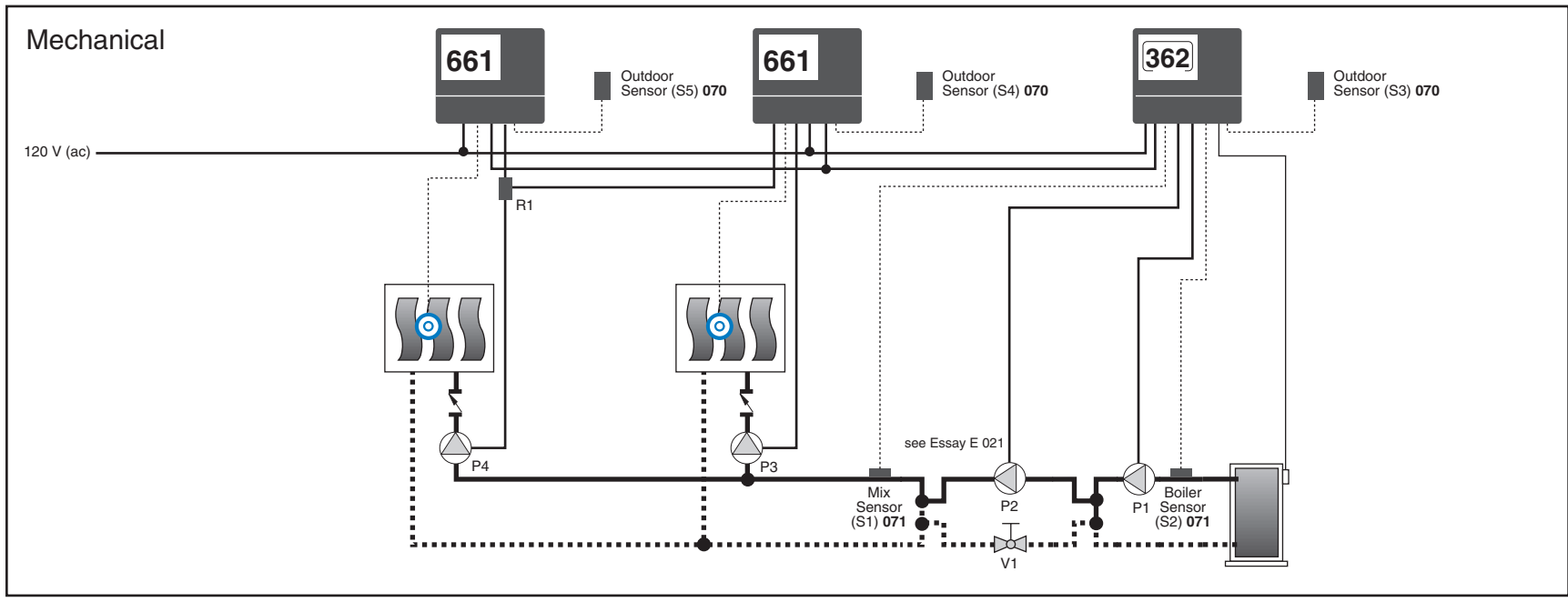
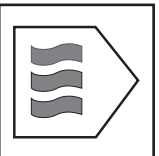

**Note:** This is only a concept drawing. The designer must determine whether this application will work in his system and must ensure compliance with code requirements. Necessary auxiliary equipment, isolation relays (for loads greater than the specified tekmar internal relay ratings), and other safety and limit devices must be added.

## System Operation

Two Snow Detector and Melting Control 661's combine with a single Mixing Control 362 in order to provide an automatic multi-zone snow melting system with Boiler Protection and Priority.

**Heat Source Details** The heat source can be either a high mass or low mass non-condensing or low temperature boiler.

**Piping Details** The variable speed injection pump is piped in primary / secondary in order to isolate the boiler loop flow rate from the mixed loop flow rate. The boiler pump provides constant flow through the boiler and ensures flow past the variable speed injection pump take-off. The mixed loop pump provides constant flow through the mixed loop and ensures flow past the mixing supply sensor. The snow melting zones are piped in parallel and the zone pumps are cycled by the 661's in order to control the slab temperature.

**Snow Melting Demand** When either 661 detects snow, they will send a Mix Demand to the 362. The 362 closes the *Mix Pmp* contact which then starts the boiler pump (P1). The control aims to maintain the mixing supply temperature at the MELTING setting. The 362 fires the boiler in order to supply heat to the mixing system loop. While the boiler is firing, the variable speed injection pump (P2) is modulated to protect the boiler from excessively low supply fluid temperatures.

All control functions and specifications are listed in the Product Catalog I 000 and Data Brochure D 362 & D 661.

Note: Since this is a priority system, it is possible for the priority zone to interrupt the non-priority zone during its melting cycle and potentially allow the non-priority zone to freeze up.



tekmar Control Systems Ltd., Canada  
 tekmar Control Systems, Inc., U.S.A.  
**Head Office: 4611 - 23rd Street**  
**Vernon, B.C. Canada V1T 4K7**  
**Tel. (250) 545-7749 Fax. (250) 545-0650**  
**Web Site: [www.tekmarcontrols.com](http://www.tekmarcontrols.com)**