

tekmar® - Application

Injection Mixing Control 351



A 351-1

07/93

The Injection Mixing Control 351 regulates the indoor air temperature of the hydronic radiant floor (HRF) heating zone by injecting hot boiler water through a two-way valve into the continuously circulating HRF zone loop. The HRF zone loop water temperature is regulated based on the HRF zone air temperature and outdoor air temperature.

Note: If pumps are used in the other zones of the system, an injection pump should be substituted for the injection zone valve to ensure consistent flow rates in the HRF zone. The type 351 would then energize a double pole relay to power the injection pump and boiler.

See balancing procedure in brochure D 351.

Mechanical

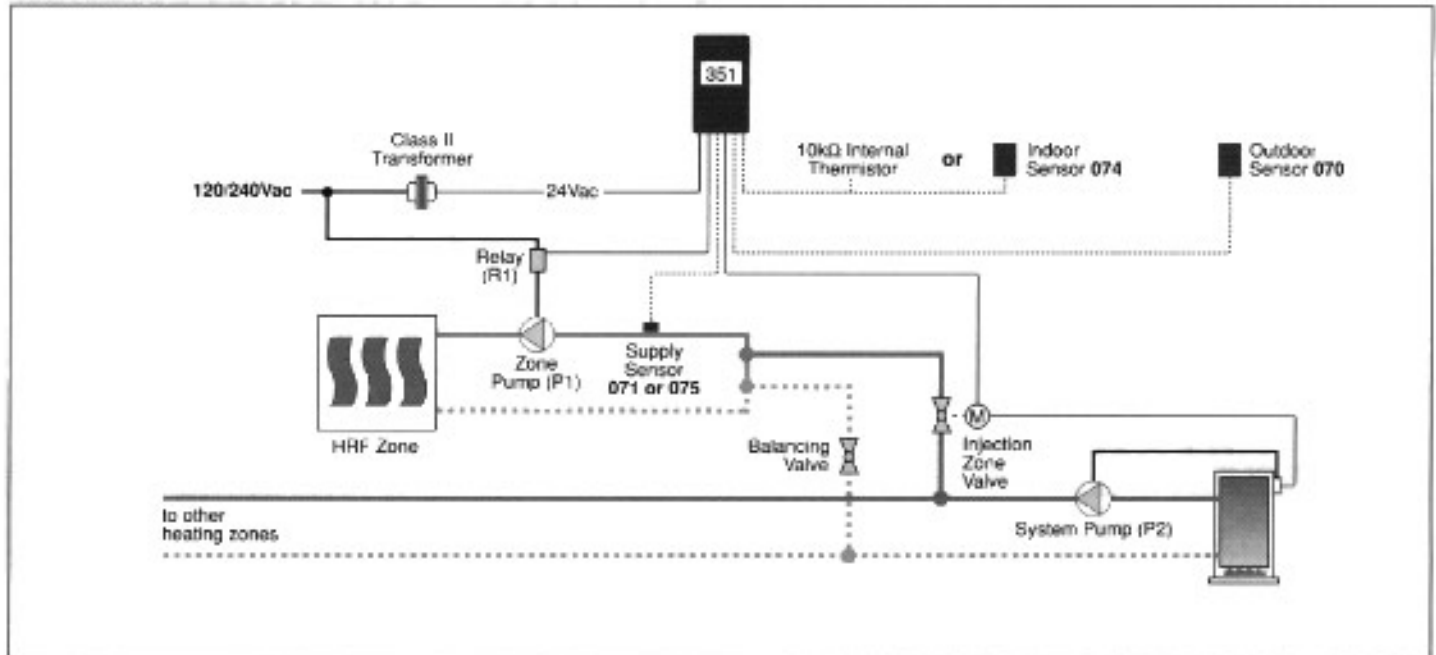

Electrical

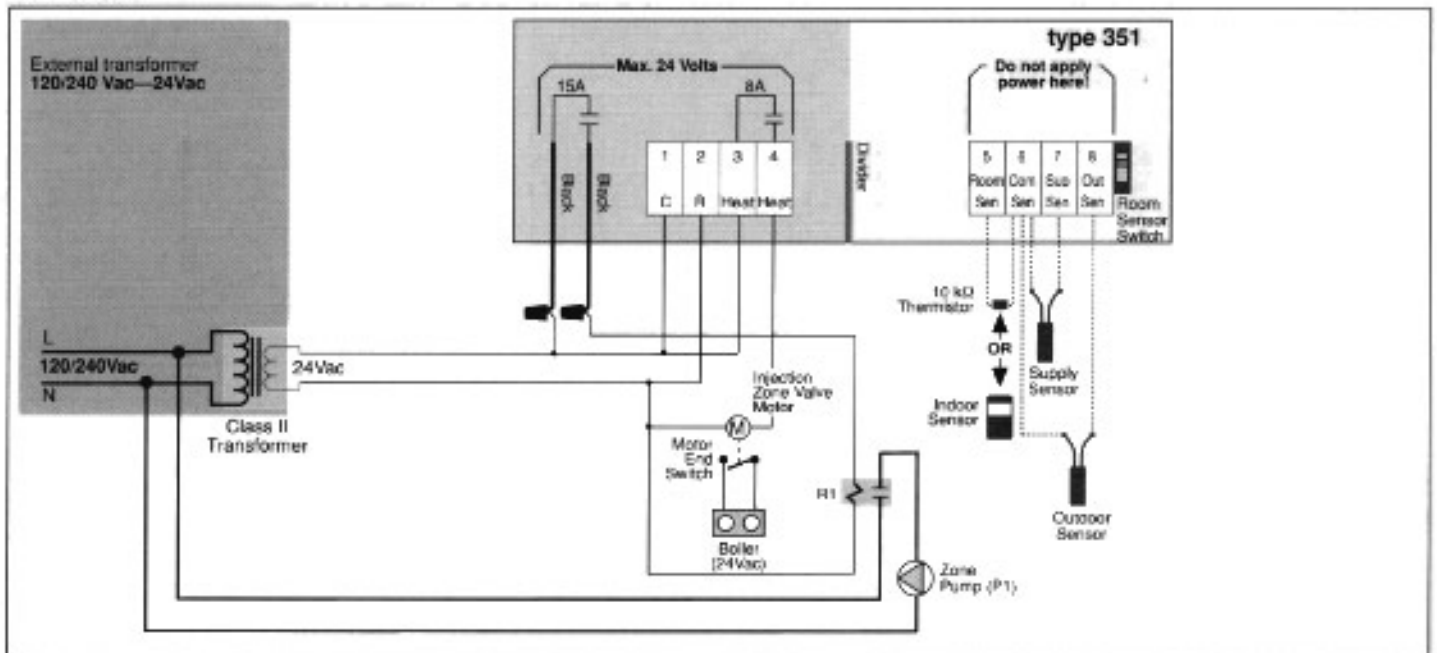

Note: This is only a concept drawing. The designer must determine whether this system will work in his application and conform to code requirements. Necessary auxiliary equipment and safety devices must be added.

Specifications

The following are minimum recommended specifications for the control in this application.

- The control shall calculate the HRF zone supply water temperature based on the control's Heating curve dial (reset ratio) setting, the Occupied dial setting, the outdoor air temperature and the HRF zone air temperature.
- The 2-way injection zone valve shall be closed if the HRF zone supply water temperature rises above the control's adjustable maximum supply water temperature setting to prevent damage to the HRF plastic piping.
- The control shall have an adjustable cycle length to prevent short operating cycles of the 2-way injection zone valve.
- The HRF zone air temperature shall be adjustable at the control (Occupied temperature setting).
- The HRF zone air temperature shall be measured by a thermistor in the control or by a tekmar Indoor Sensor 074 mounted remotely from the control.
- The zone pump shall run continuously unless the outdoor air temperature is warmer than the control's calculated Warm Weather Shut Down (WWSD) point.
- The WWSD point shall be calculated based on the occupied temperature setting and the HRF zone air temperature.
- The control shall have a test button which opens the 2-way injection zone valve and turns on the zone pump (P1).
- The control shall be an electronic control with 8 and 15 Amp relay contacts and indicator lights for control functions and status.
- The control enclosure must be able to be mounted on standard North American electrical boxes.
- The location of the control must be within its specified temperature and humidity ranges with the installer ensuring that the control and its wiring are isolated and/or shielded from strong sources of electromagnetic noise.
- The control components required from tekmar are one Injection Mixing Control 351.

Settings

Injection Mixing Control 351	Adjustment Range	Recommended Initial Settings
Maximum	100 to 200°F (38 to 93°C)	
Cycle length	- to +	
Heating curve	0.4 to 3.6	
Occupied temperature	40 to 85°F (4 to 29°C)	

- Room temperature sensor On/Off Switch setting = On

Additional Information

- For control installation and testing instructions see Brochures D 001 and D 351.
- For other control applications see Application Register A 000.
- For detailed control operation and function description see Essays E 001 and E 002.

tekmar® - Application

Injection Mixing Control 351



A 351-2

07/93

DHW is generated in the water heater. The Injection Mixing Control 351 regulates the indoor air temperature of the hydronic radiant floor (HRF) heating zone by injecting DHW through a 2-way zone valve into the continuously circulating HRF zone loop. The HRF zone loop water temperature is regulated based on the HRF zone air temperature and outdoor air temperature.

Important Note: The balancing procedure in Data Brochure D 351 must be modified because of the plumbing of this particular application.

The balancing valve works in reverse to the balancing valve in the D 351 procedure. Where the D 351 asks to close the balancing valve at the beginning of the procedure; this application requires the valve to be fully opened, and then gradually closed to increase the supply water temperature. See Data Brochure D 351.

Mechanical

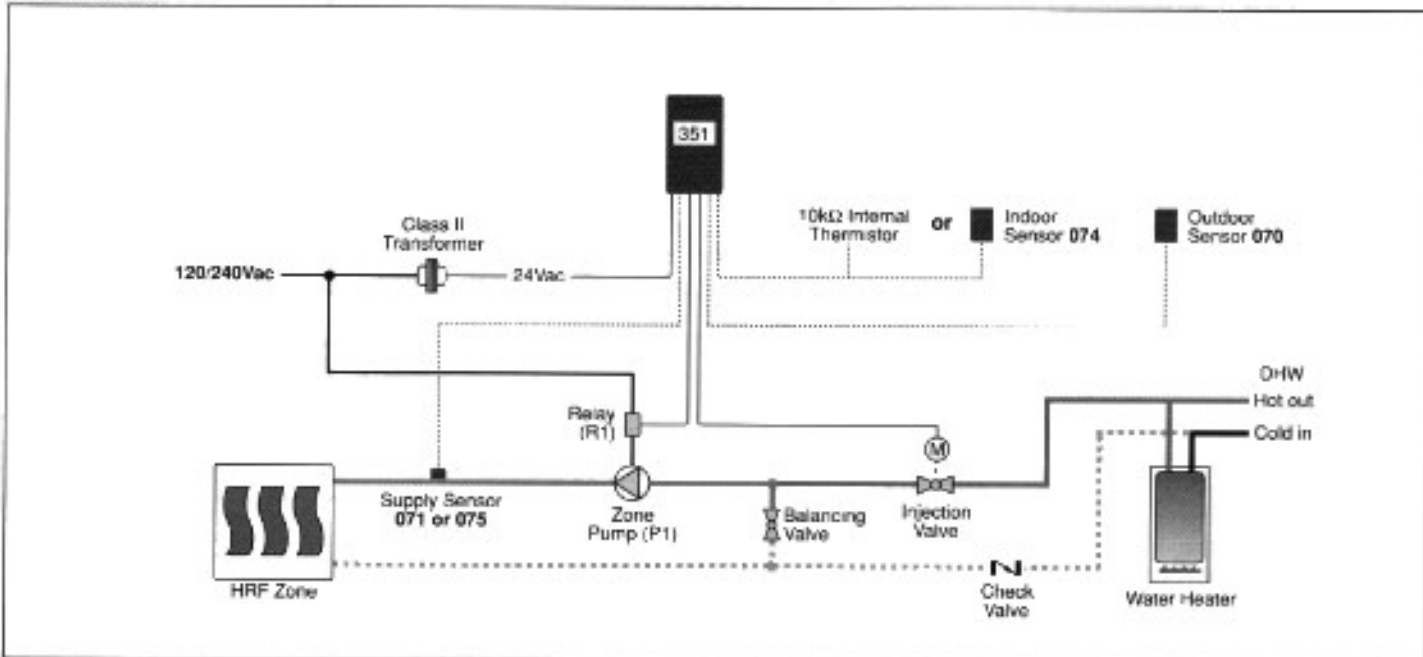

Electrical

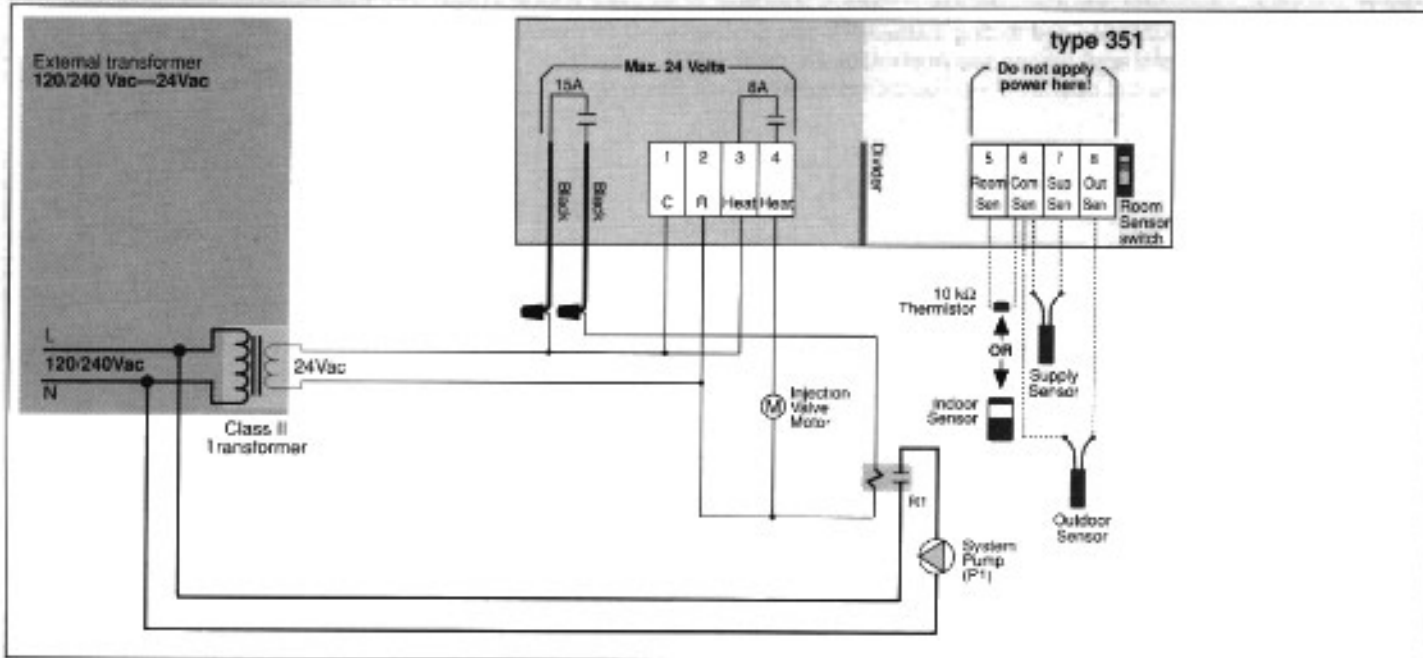

Note: This is only a concept drawing. The designer must determine whether this system will work in his application and conform to code requirements. Necessary auxiliary equipment and safety devices must be added.

Specifications

The following are minimum recommended specifications for the control in this application.

- All components shall be of non corrosive materials suitable for domestic hot water (DHW) and open loop heating applications.
 - The application of a water heater for both DHW and heating use must conform to local plumbing and building standards.
 - A heat exchanger shall be installed between the HRF zone loop and injection valve if the heating system supply water needs to be isolated from the DHW.
 - The water heater shall generate the DHW.
 - The DHW temperature shall be set at the water heater's aquastat.
 - The HRF zone loop design water temperature shall be lower than the required DHW temperature.
 - The control shall calculate the HRF zone supply water temperature based on the control's Heating curve dial (reset ratio) setting, the Occupied dial setting, the outdoor air temperature and the HRF zone air temperature.
 - The 2-way injection zone valve shall be closed if the HRF zone supply water temperature rises above the control's adjustable maximum supply water temperature setting to prevent damage to the HRF plastic piping.
 - The control shall have an adjustable cycle length to prevent short operating cycles of the 2-way injection zone valve.
 - The HRF zone air temperature shall be adjustable at the control (Occupied temperature setting).
 - The HRF zone air temperature shall be measured by a thermistor in the control or a tekmar Indoor Sensor 074 mounted remotely from the control.
 - The zone pump shall run continuously unless the outdoor air temperature is warmer than the control's calculated Warm Weather Shut Down (WWSD) point.
 - The WWSD point shall be calculated based on the occupied temperature setting and the HRF zone air temperature.
 - The control shall have a test button which opens the 2-way injection zone valve.
 - The control shall be an electronic control with 8 and 15 Amp relay contacts and indicator lights for control functions and status.
 - The control enclosure must be able to be mounted on standard North American electrical boxes.
 - The location of the control must be within its specified temperature and humidity ranges with the installer ensuring that the control and its wiring are isolated and/or shielded from strong sources of electromagnetic noise.
- The control components required from tekmar are one Injection Mixing Control 351.

Settings

Injection Mixing Control 351	Adjustment Range	Recommended Initial Settings
Maximum	100 to 200°F (38 to 93°C)	
Cycle length	- to +	
Heating curve	0.4 to 3.6	
Occupied temperature	40 to 85°F (4 to 29°C)	

- Room temperature sensor On/Off Switch setting = On

Additional Information

- For control installation and testing instructions see Brochures: D 001 and D 351.
- For other control applications see Application Register A 000.
- For detailed control operation and function description see Essays: E 001 and E 002.

In North America: tekmar Control Systems Ltd., Canada
 tekmar Control Systems, Inc., U.S.A.
 Head Office: 4611 - 23rd Street
 Vernon, B.C. Canada V1T 4K7
 Tel. (604) 545-7749 Fax. (604) 545-0650