

tekmar® - Application

Four Stage Boiler Control 254

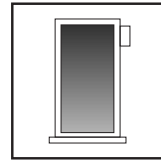

A 254-1

06/00

The Four Stage Boiler Control 254 regulates the heating system supply water temperature based on the outdoor temperature by cycling the boilers on and off. The system pump and boilers are turned off in warm weather.

Mechanical

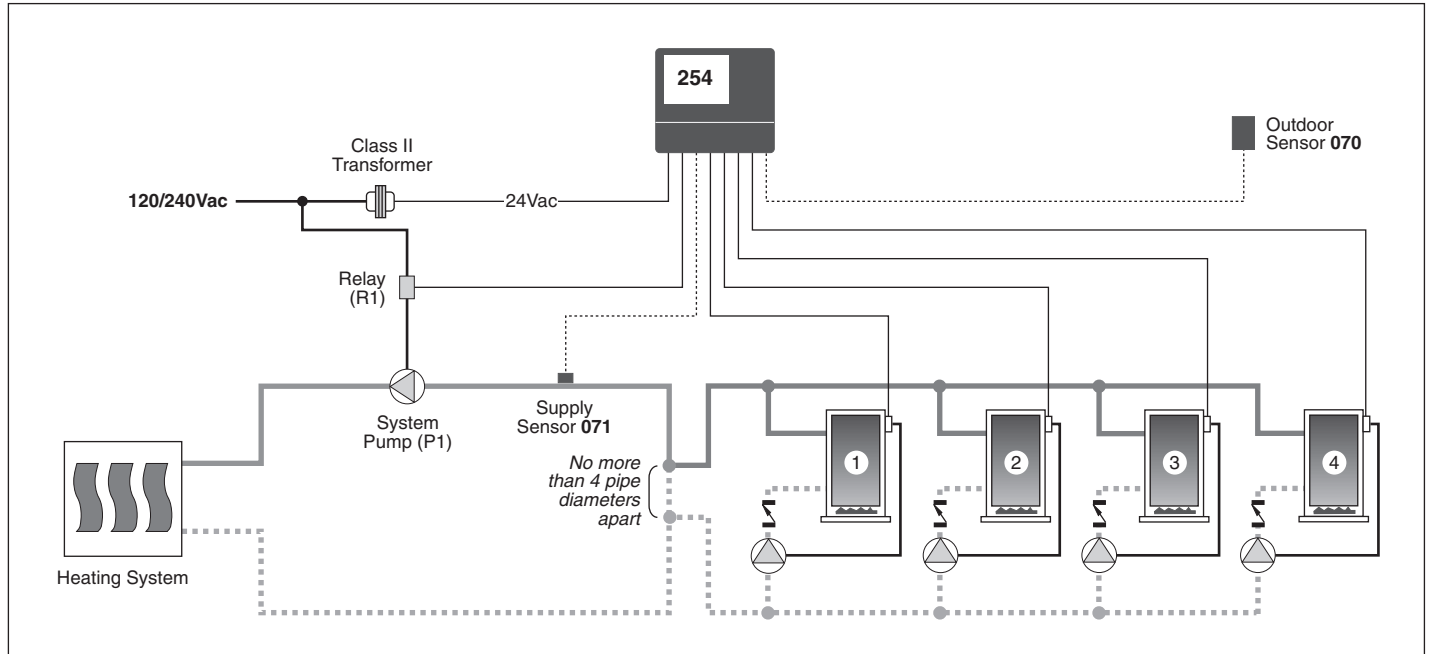

Electrical

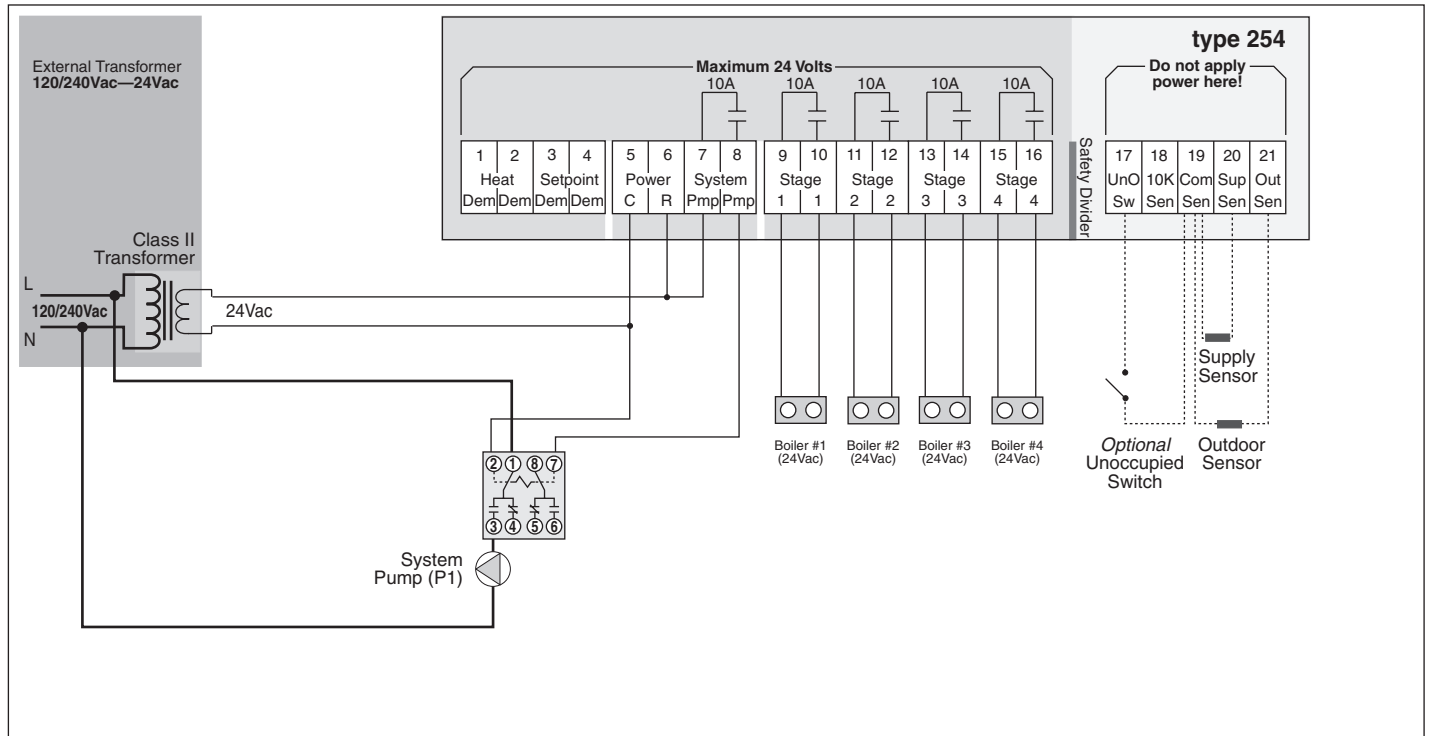

Note: This is only a concept drawing. Designers must determine whether this system will work in each application and must ensure compliance with code requirements. Necessary auxiliary equipment and safety devices must be added.

Specifications

The following are minimum recommended specifications for the control in this application.

- The heating system supply water temperature shall be based on the outdoor air temperature and the control's Heating Curve (reset ratio) and Occupied or Unoccupied (when in setback) dial settings.
 - The control shall have an Unoccupied (setback) switch or timer input to enable the control's Unoccupied temperature dial.
 - The pump and the boiler(s) shall be turned off whenever the outdoor air temperature is warmer than the control's Warm Weather Shut Down (WWSD) point.
 - The Occupied or Unoccupied temperature dial setting shall be the control's WWSD point.
 - During WWSD the system pump (P1) shall be operated for 20 seconds every 3 days to prevent seizure during long idle periods.
 - The control shall have an adjustable Minimum Supply water temperature setting to help prevent condensation of flue gases and subsequent corrosion and blockage of boiler heat exchangers and chimneys.
 - The control shall have an adjustable Boiler Differential and shall calculate time delay between boiler cycles and stages to prevent short operating cycles of the boiler(s).
 - The options for rotating the boiler firing sequence shall be based on the boiler's running time.
 - The control shall continuously monitor its temperature sensors and provide a LED error message if one becomes shorted or disconnected.
 - The control shall be microprocessor-based, have 10 Amp relay contacts and have indicator lights for control function and status.
 - The control shall have a test button which activates a pre-programmed test sequence to test all sensors and control outputs.
 - The control enclosure shall be compatible with standard North American wiring hardware.
 - The control shall be installed in an environment that is within the specified temperature and humidity ranges. The installer must ensure that the control and its wiring are isolated and/or shielded from strong sources of electromagnetic noise.
- The control system component required from tekmar is a Four Stage Boiler Control 254.

Settings

Four Stage Boiler Control 254

Occupied
Unoccupied
Heating Curve
Setpoint
Minimum Supply
Boiler Differential

Adjustment Range

35 to 105°F (2 to 41°C)
35 to 105°F (2 to 41°C)
0.4 to 3.6
110 to 230°F (43 to 110°C)
Off, 80 to 170°F (27 to 77°C)
2 to 42°F (1 to 23°C)

Recommended Initial Settings

Four Stage Boiler Control 254 DIP switch settings for this application.

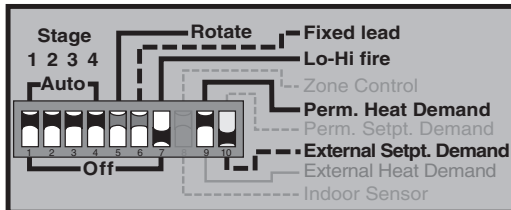

= required setting for this application.



= optional setting for this application.



= does not matter, switch not used for this application.

(see Data Brochure D 254)

Additional Information

- For control installation, testing and operating instructions see Brochure D 001 and D 254.
- For other control applications see Application Register A 000.
- For control theory and system integration details see E 001 and E 002.



tekmar Control Systems Ltd., Canada
tekmar Control Systems, Inc., U.S.A.
Head Office: 4611 - 23rd Street
Vernon, B.C. Canada V1T 4K7
Tel. (250) 545-7749 Fax. (250) 545-0650
Web Site: www.tekmarcontrols.com



tekmar® - Application

Four Stage Boiler Control 254

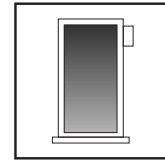

A 254-2

06/00

The Four Stage Boiler Control 254 turns on the system pump and regulates the heating system supply water temperature based on the outdoor temperature by cycling the boilers on and off when it receives a 24Vac heat demand signal. The system pump and boilers are turned off in warm weather and when there is no heat demand signal.

Mechanical

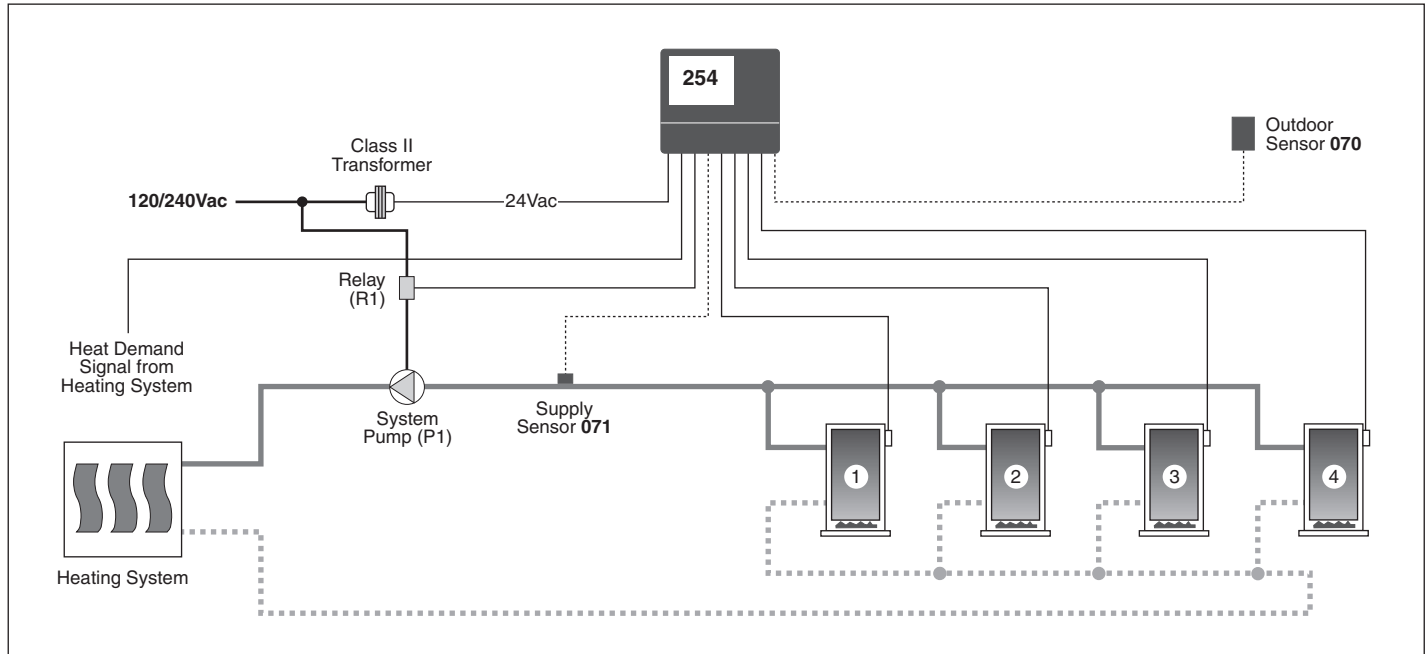

Electrical

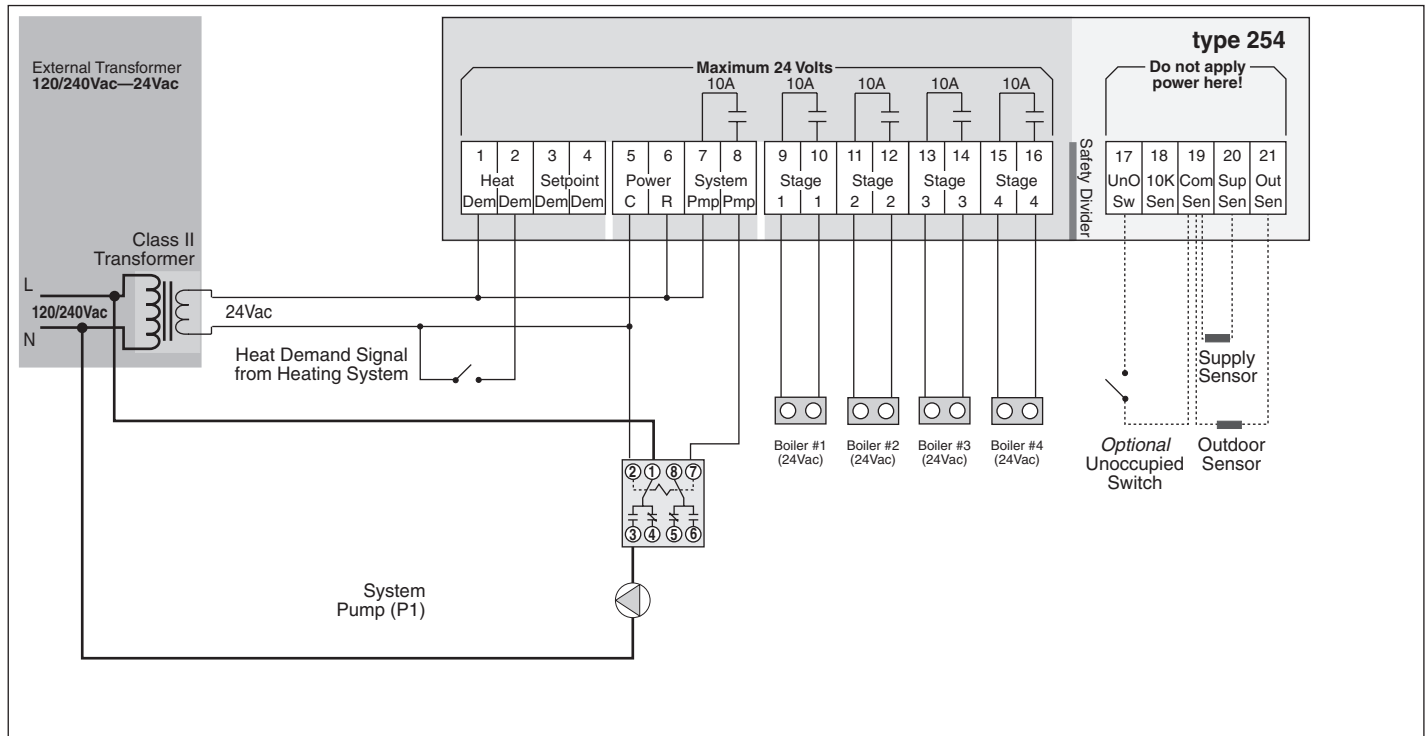

Note: This is only a concept drawing. Designers must determine whether this system will work in each application and must ensure compliance with code requirements. Necessary auxiliary equipment and safety devices must be added.

Specifications

The following are minimum recommended specifications for the control in this application.

- The heating system supply water temperature shall be based on the outdoor air temperature and the control's Heating Curve (reset ratio) and Occupied or Unoccupied (when in setback) dial settings.
- The control shall have an Unoccupied (setback) switch or timer input to enable the control's Unoccupied temperature dial.
- The pump and the boiler(s) shall be turned off whenever the outdoor air temperature is warmer than the control's Warm Weather Shut Down (WWSD) point or when there is a no Heat Demand signal.
- The Occupied or Unoccupied temperature dial setting shall be the control's WWSD point.
- During WWSD the system pump (P1) shall be operated for 20 seconds every 3 days to prevent seizure during long idle periods.
- The control shall have an adjustable Minimum Supply water temperature setting to help prevent condensation of flue gases and subsequent corrosion and blockage of boiler heat exchangers and chimneys.
- The control shall have an adjustable Boiler Differential and shall calculate time delay between boiler cycles and stages to prevent short operating cycles of the boiler(s).
- The options for rotating the boiler firing sequence shall be based on the boiler's running time.
- The control shall continuously monitor its temperature sensors and provide a LED error message if one becomes shorted or disconnected.
- The control shall be microprocessor-based, have 10 Amp relay contacts and have indicator lights for control function and status.
- The control shall have a test button which activates a pre-programmed test sequence to test all sensors and control outputs.
- The control enclosure shall be compatible with standard North American wiring hardware.
- The control shall be installed in an environment that is within the specified temperature and humidity ranges. The installer must ensure that the control and its wiring are isolated and/or shielded from strong sources of electromagnetic noise.
- The control system component required from tekmar is a Four Stage Boiler Control 254.

Settings

Four Stage Boiler Control 254

Occupied
Unoccupied
Heating Curve
Setpoint
Minimum Supply
Boiler Differential

Adjustment Range

35 to 105°F (2 to 41°C)
35 to 105°F (2 to 41°C)
0.4 to 3.6
110 to 230°F (43 to 110°C)
Off, 80 to 170°F (27 to 77°C)
2 to 42°F (1 to 23°C)

Recommended Initial Settings

Four Stage Boiler Control 254 DIP switch settings for this application.

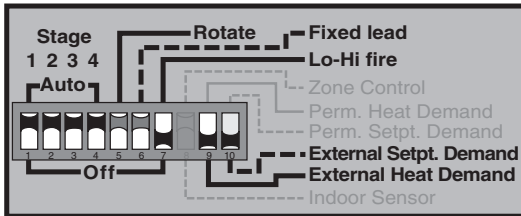

 = required setting for this application.

 = optional setting for this application.

 = does not matter, switch not used for this application.

(see Data Brochure D 254)

Additional Information

- For control installation, testing and operating instructions see Brochure D 001 and D 254.
- For other control applications see Application Register A 000.
- For control theory and system integration details see E 001 and E 002.



tekmar Control Systems Ltd., Canada
tekmar Control Systems, Inc., U.S.A.
Head Office: 4611 - 23rd Street
Vernon, B.C. Canada V1T 4K7
Tel. (250) 545-7749 Fax. (250) 545-0650
Web Site: www.tekmarcontrols.com



tekmar® - Application

Four Stage Boiler Control 254

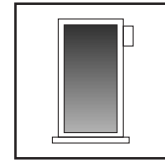

A 254-3

06/00

The Four Stage Boiler Control 254 turns the DHW pump on and cycles the Lo-Hi fire boiler stages on and off to control the supply temperature to the DHW tank whenever there is a setpoint demand signal.

Mechanical

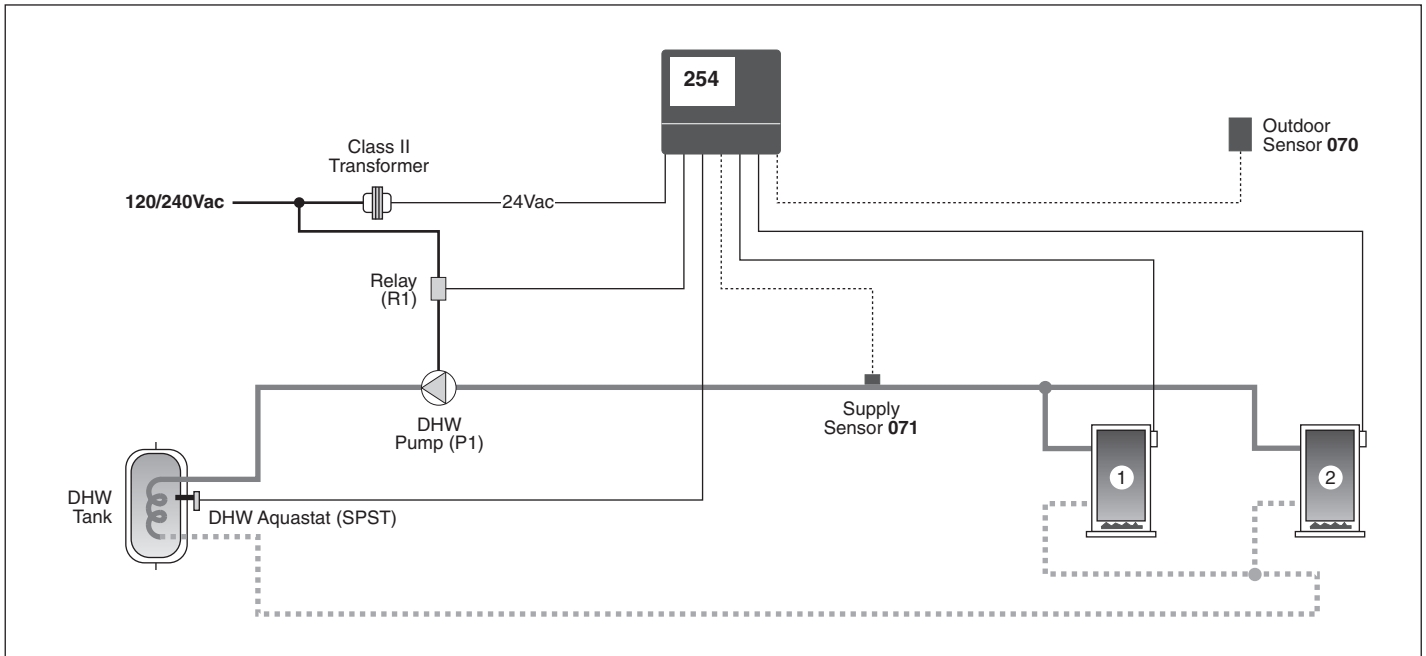

Electrical

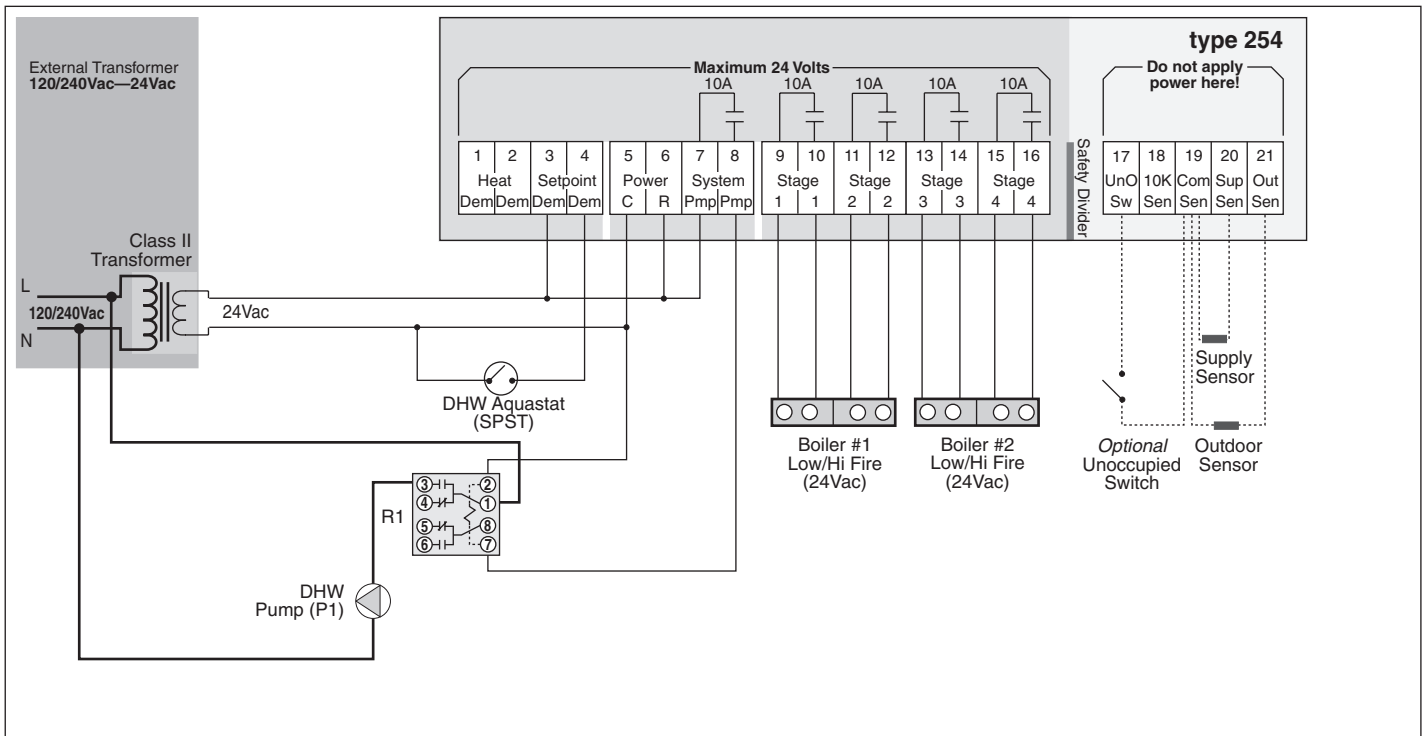

Note: This is only a concept drawing. Designers must determine whether this system will work in each application and must ensure compliance with code requirements. Necessary auxiliary equipment and safety devices must be added.

Specifications

The following are minimum recommended specifications for the control in this application.

- The supply water temperature shall be based on the Setpoint dial setting.
- The pump and the boiler(s) shall be turned off until there is a "call for DHW" from the DHW Aquastat.
- The control shall have an adjustable Minimum Supply water temperature setting to help prevent condensation of flue gases and subsequent corrosion and blockage of boiler heat exchangers and chimneys.
- The control shall have an adjustable Boiler Differential and shall calculate time delay between boiler cycles and stages to prevent short operating cycles of the boiler(s).
- The options for rotating the boiler firing sequence shall be based on the boiler's running time.
- The control shall twin Lo-Hi Fire stages as one boiler for rotation purposes.
- The control shall continuously monitor its temperature sensors and provide a LED error message when one is shorted or disconnected.
- The control shall be microprocessor-based, have 10 Amp relay contacts and have indicator lights for control function and status.
- The control shall have a test button which activates a pre-programmed test sequence to test all sensors and control outputs.
- The control enclosure shall be compatible with standard North American wiring hardware.
- The control shall be installed in an environment that is within the specified temperature and humidity ranges. The installer must ensure that the control and its wiring are isolated and/or shielded from strong sources of electromagnetic noise.
- The control system component required from tekmar is a Four Stage Boiler Control 254.

Settings

Four Stage Boiler Control 254

Occupied
Unoccupied
Heating Curve
Setpoint
Minimum Supply
Boiler Differential

Adjustment Range

35 to 105°F (2 to 41°C)
35 to 105°F (2 to 41°C)
0.4 to 3.6
110 to 230°F (43 to 110°C)
Off, 80 to 170°F (27 to 77°C)
2 to 42°F (1 to 23°C)

Recommended Initial Settings

does not matter
does not matter
does not matter

Four Stage Boiler Control 254 DIP switch settings for this application.

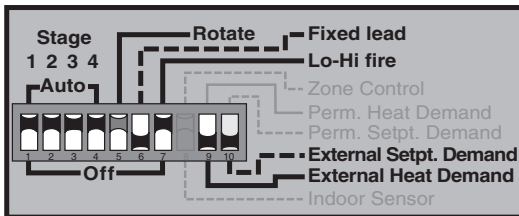

= required setting for this application.

= optional setting for this application.

= does not matter, switch not used for this application.

(see Data Brochure D 254)

Additional Information

- For control installation, testing and operating instructions see Brochure D 001 and D 254.
- For other control applications see Application Register A 000.
- For control theory and system integration details see E 001 and E 002.



tekmar Control Systems Ltd., Canada
tekmar Control Systems, Inc., U.S.A.
Head Office: 4611 - 23rd Street
Vernon, B.C. Canada V1T 4K7
Tel. (250) 545-7749 Fax. (250) 545-0650
Web Site: www.tekmarcontrols.com



tekmar® - Application

Four Stage Boiler Control 254

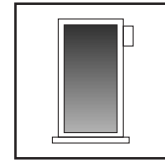

A 254-4

06/00

When the Four Stage Boiler Control 254 receives a 24Vac heat demand signal, it turns on the system pump and regulates the heating system supply water temperature based on the outdoor temperature by cycling the boilers on and off. The system pump and boilers are turned off in warm weather. When the DHW aquastat closes, the DHW pump is turned on, the system pump is turned off, the control receives a 24Vac setpoint demand signal and the supply temperature to the DHW tank is controlled at the setpoint temperature.

Mechanical

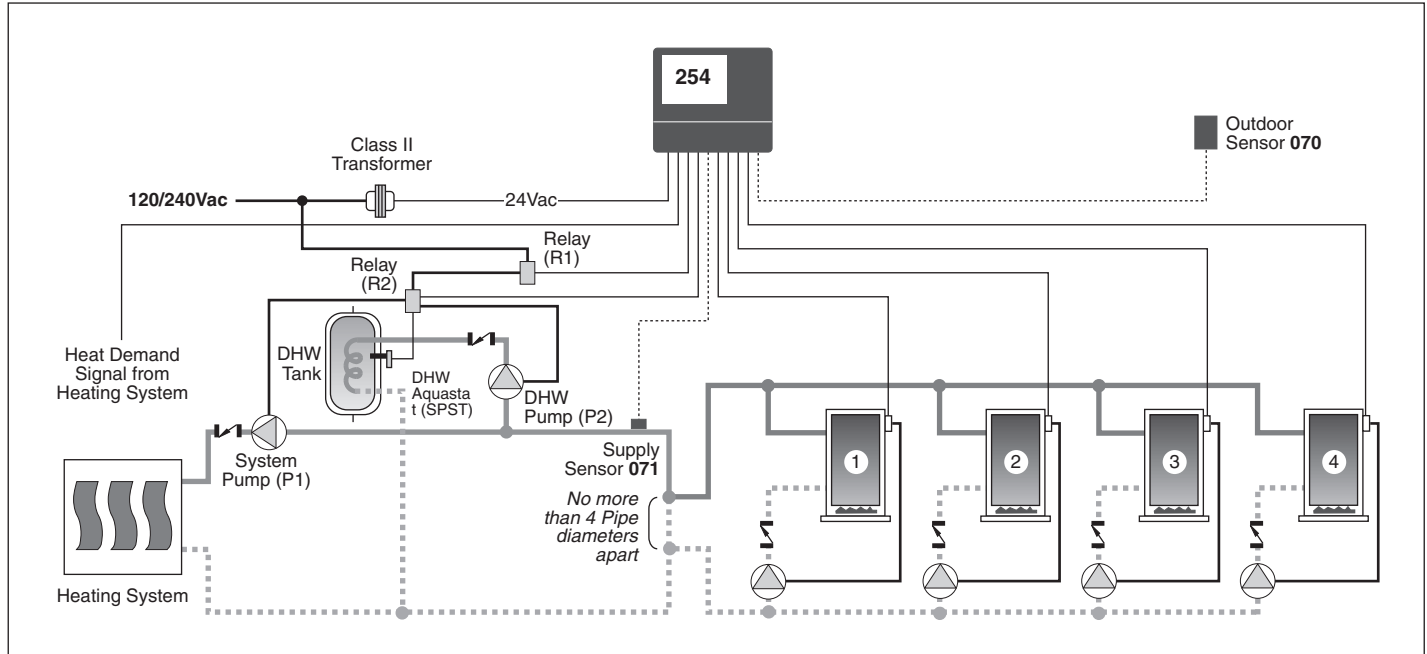

Electrical

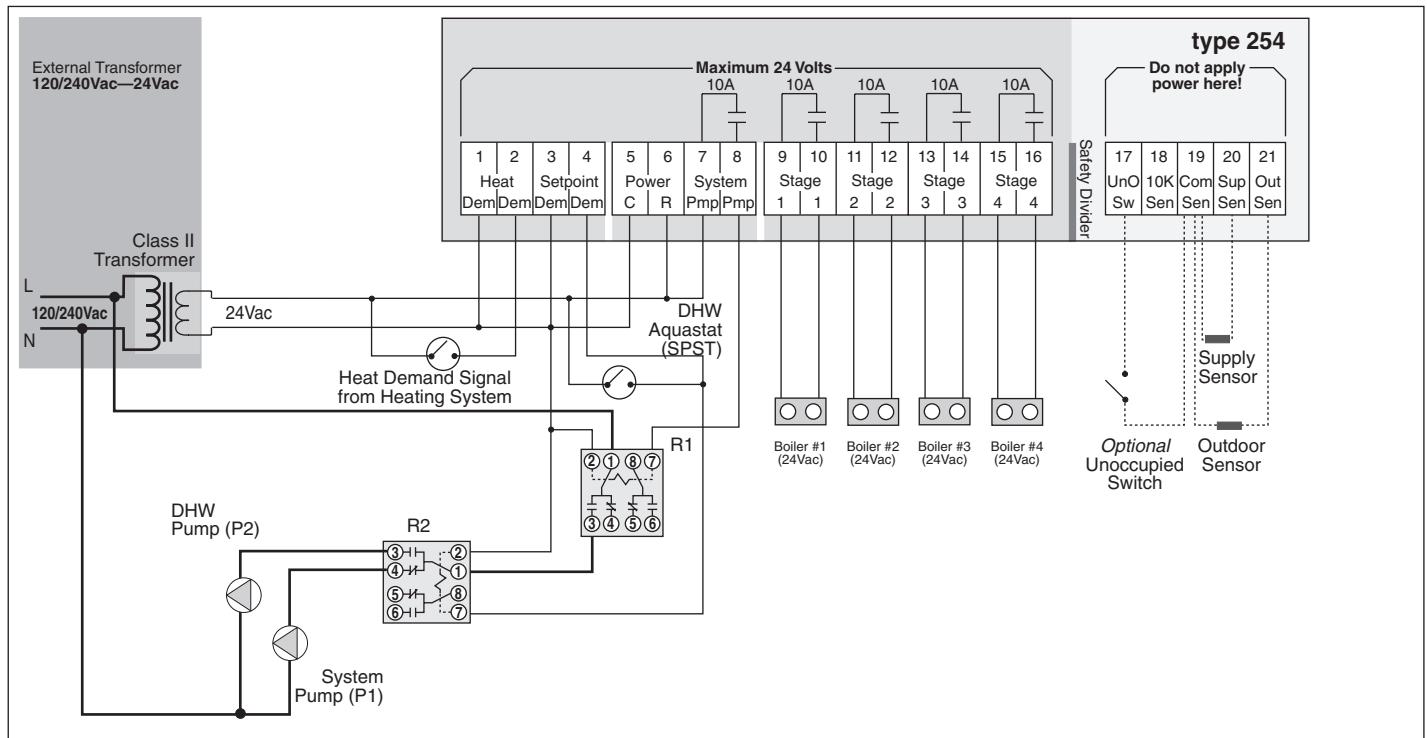

Note: This is only a concept drawing. Designers must determine whether this system will work in each application and must ensure compliance with code requirements. Necessary auxiliary equipment and safety devices must be added.

Specifications

The following are minimum recommended specifications for the control in this application.

- The heating system supply water temperature shall be based on the outdoor air temperature and the control's Heating Curve (reset ratio) and Occupied or Unoccupied (when in setback) dial settings.
 - The control shall have an Unoccupied (setback) switch or timer input to enable the control's Unoccupied temperature dial.
 - The pump and the boilers shall be turned off until there is a "call for heat" from the heating system switch and the outdoor air temperature is colder than the control's Warm Weather Shut Down (WWSD) point or there is a "call for DHW" from the DHW aquastat.
 - The Occupied or Unoccupied temperature dial setting shall be the control's WWSD point.
 - The control shall have an adjustable Minimum Supply water temperature setting to help prevent condensation of flue gases and subsequent corrosion and blockage of boiler heat exchangers and chimneys.
 - The control shall have an adjustable Boiler Differential and shall calculate time delay between boiler cycles and stages to prevent short operating cycles of the boilers.
 - On a "call for DHW" the system pump (P1) shall be turned off, the DHW pump shall be turned on and the boilers controlled to provide supply water at the Setpoint temperature. The DHW supply water temperature shall be adjusted by a Setpoint dial on the control.
 - The options for rotating the boiler firing sequence shall be based on the boiler's running time.
 - The control shall continuously monitor its temperature sensors and provide a LED error message when one is shorted or disconnected.
 - The control shall be microprocessor-based, have 10 Amp relay contacts and have indicator lights for control function and status.
 - The control shall have a test button which activates a pre-programmed test sequence to test all sensors and control outputs.
 - The control enclosure shall be compatible with standard North American wiring hardware.
 - The control shall be installed in an environment that is within the specified temperature and humidity ranges. The installer must ensure that the control and its wiring are isolated and/or shielded from strong sources of electromagnetic noise.
- The control system component required from tekmar is a Four Stage Boiler Control 254.

Settings



Four Stage Boiler Control 254

	Adjustment Range
Occupied	35 to 105°F (2 to 41°C)
Unoccupied	35 to 105°F (2 to 41°C)
Heating Curve	0.4 to 3.6
Setpoint	110 to 230°F (43 to 110°C)
Minimum Supply	Off, 80 to 170°F (27 to 77°C)
Boiler Differential	2 to 42°F (1 to 23°C)

Recommended Initial Settings

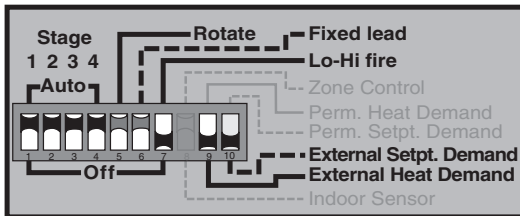
Four Stage Boiler Control 254 DIP switch settings for this application.



-  = required setting for this application.
-  = optional setting for this application.
-  = does not matter, switch not used for this application.

(see Data Brochure D 254)

Additional Information

- For control installation, testing and operating instructions see Brochure D 001 and D 254.
- For other control applications see Application Register A 000.
- For control theory and system integration details see E 001 and E 002.



tekmar Control Systems Ltd., Canada
 tekmar Control Systems, Inc., U.S.A.
Head Office: 4611 - 23rd Street
Vernon, B.C. Canada V1T 4K7
Tel. (250) 545-7749 Fax. (250) 545-0650
Web Site: www.tekmarcontrols.com

