

tekmar® - Application

Two Stage Boiler & DHW Control 252

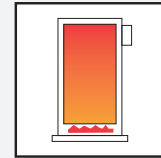

A 252-1

11/97

The Two Stage Boiler & DHW Control 252 regulates the heating system supply water temperature based on the outdoor air temperature by cycling the boilers on and off. The system pump and boilers are turned off in warm weather.

Mechanical

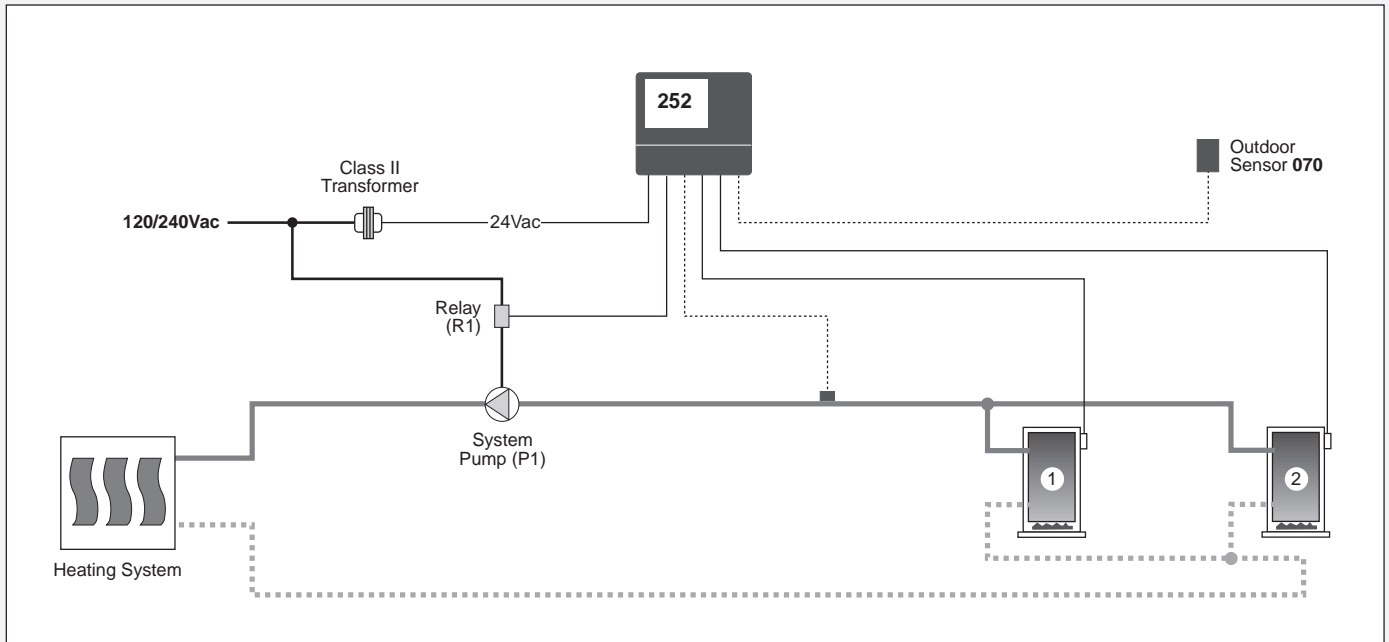

Electrical

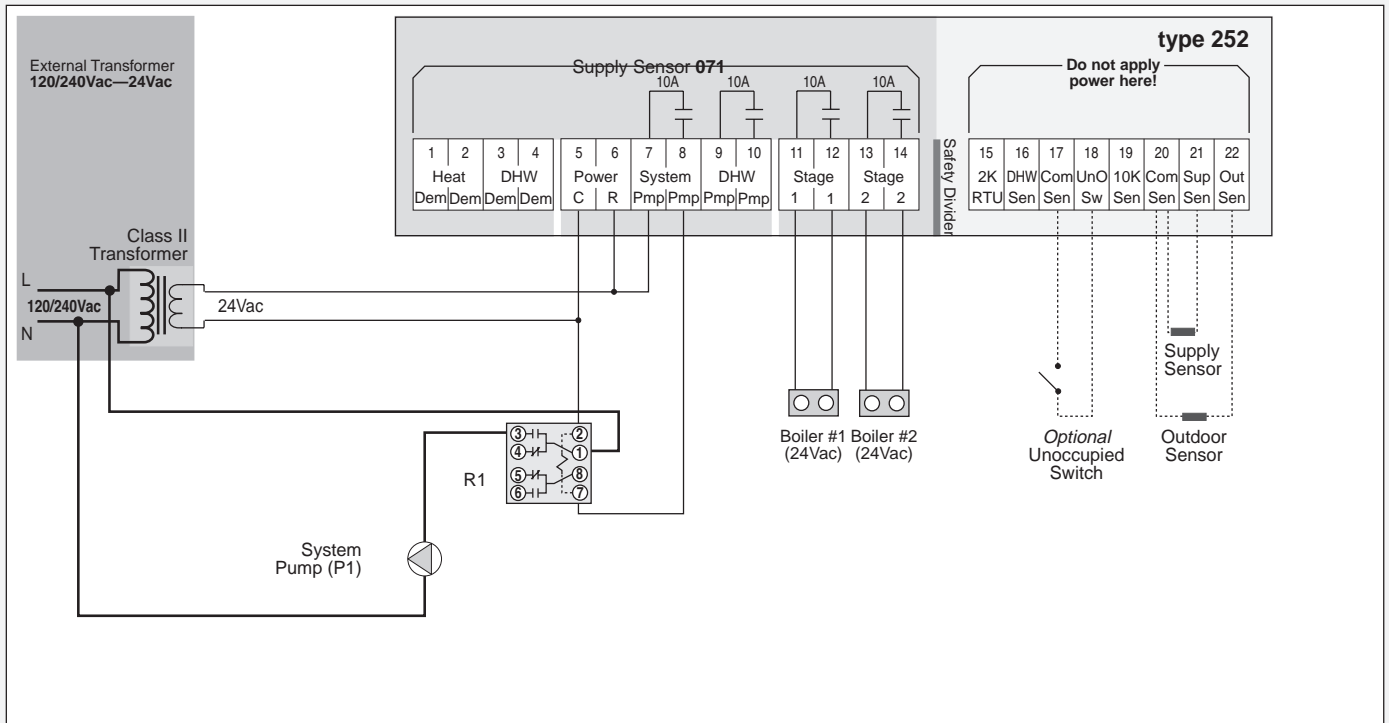

Note: This is only a concept drawing. Designers must determine whether this system will work in each application and must ensure compliance with code requirements. Necessary auxiliary equipment and safety devices must be added.

Specifications

The following are minimum recommended specifications for the control in this application.

- The heating system supply water temperature shall be based on the outdoor air temperature and the control's Heating Curve (reset ratio) and Occupied or Unoccupied (when in setback) dial settings.
 - The control shall have an Unoccupied (setback) switch or timer input to enable the control's Unoccupied temperature dial.
 - The pump and the boiler(s) shall be turned off whenever the outdoor air temperature is warmer than the control's Warm Weather Shut Down (WWSD) point.
 - The Occupied or Unoccupied temperature dial setting shall be the control's WWSD point.
 - During WWSD the system pump (P1) shall be operated for 20 seconds every 3 days to prevent seizure during long idle periods.
 - The control shall have an adjustable Minimum Supply water temperature setting to help prevent condensation of flue gases and subsequent corrosion and blockage of boiler heat exchangers and chimneys.
 - The control shall have an adjustable Boiler Differential and shall calculate time delay between boiler cycles and stages to prevent short operating cycles of the boiler(s).
 - The options for rotation shall be based on the boiler's running time.
 - The control shall continuously monitor its temperature sensors and provide a LED error message if one becomes shorted or disconnected.
 - The control shall be microprocessor-based, have 10 Amp relay contacts and have indicator lights for control function and status.
 - The control shall have a test button which activates a pre-programmed test sequence to test all sensors and control outputs.
 - The control enclosure shall be compatible with standard North American wiring hardware.
 - The control shall be installed in an environment that is within the specified temperature and humidity ranges. The installer must ensure that the control and its wiring are isolated and/or shielded from strong sources of electromagnetic noise.
- The control system component required from tekmar is a Two Stage Boiler & DHW Control 252.

Settings

Two Stage Boiler & DHW Control 252

	Adjustment Range
Occupied	35 to 105°F (2 to 41°C)
Unoccupied	35 to 105°F (2 to 41°C)
Heating Curve	0.4 to 3.6
DHW Supply	80 to 200°F (27 to 93°C)
Minimum Supply	Off, 80 to 170°F (27 to 77°C)
Boiler Differential	2 to 42°F (1 to 23°C)

Recommended Initial Settings

Two Stage Boiler & DHW Control 252 DIP switch settings for this application.

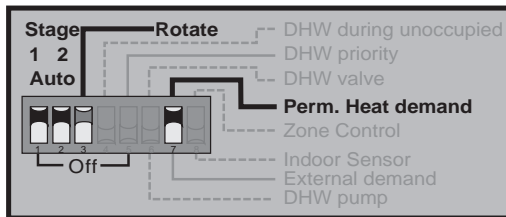

 = required setting for this application.

 = optional setting for this application.

 = does not matter, switch not used for this application.

(see Data Brochure D 252)

Additional Information

- For control installation, testing and operating instructions see Brochure D 001 and D 252.
- For other control applications see Application Register A 000.
- For control theory and system integration details see E 001 and E 002.



tekmar® - Application

Two Stage Boiler & DHW Control 252

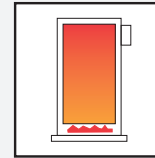
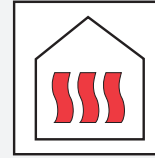
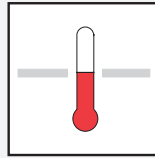

A 252-2
11/97

The Two Stage Boiler & DHW Control 252 regulates the heating system supply water temperature based on the outdoor and indoor air temperatures by cycling the boilers on and off. Domestic Hot Water temperature is measured by a DHW Sensor 071 (**ordered separately**). DHW generation uses a pump and can have priority over space heating.

Mechanical

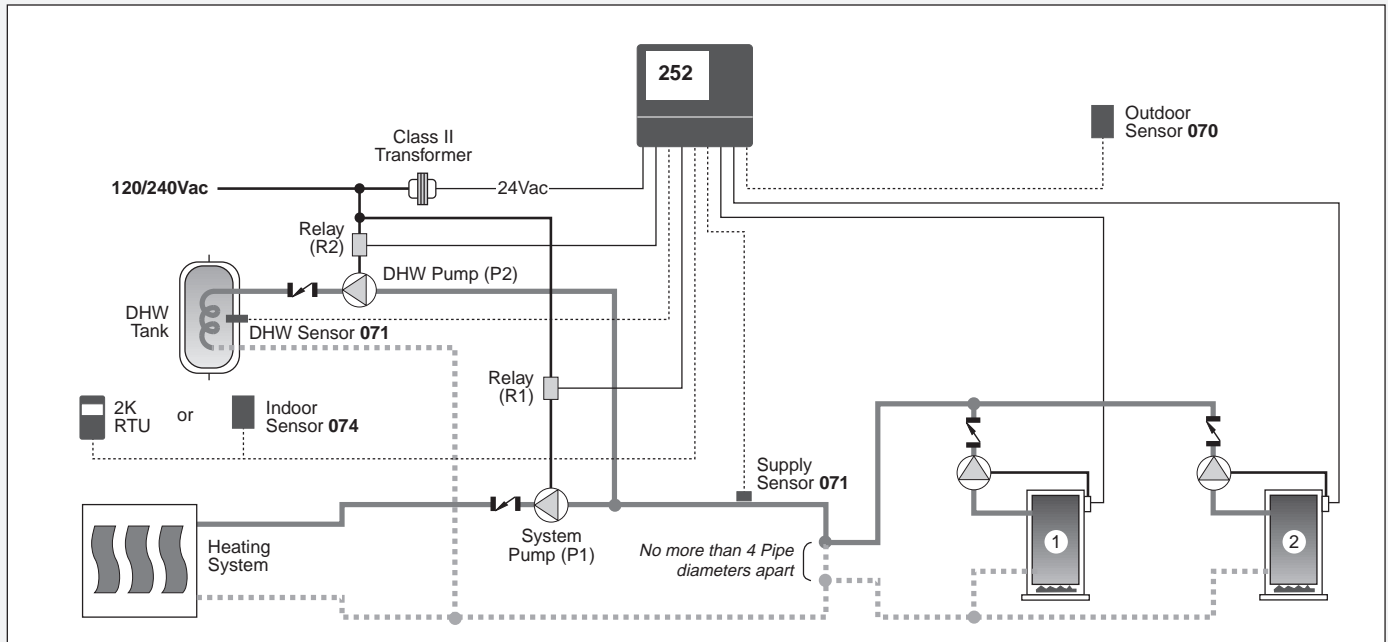

Electrical

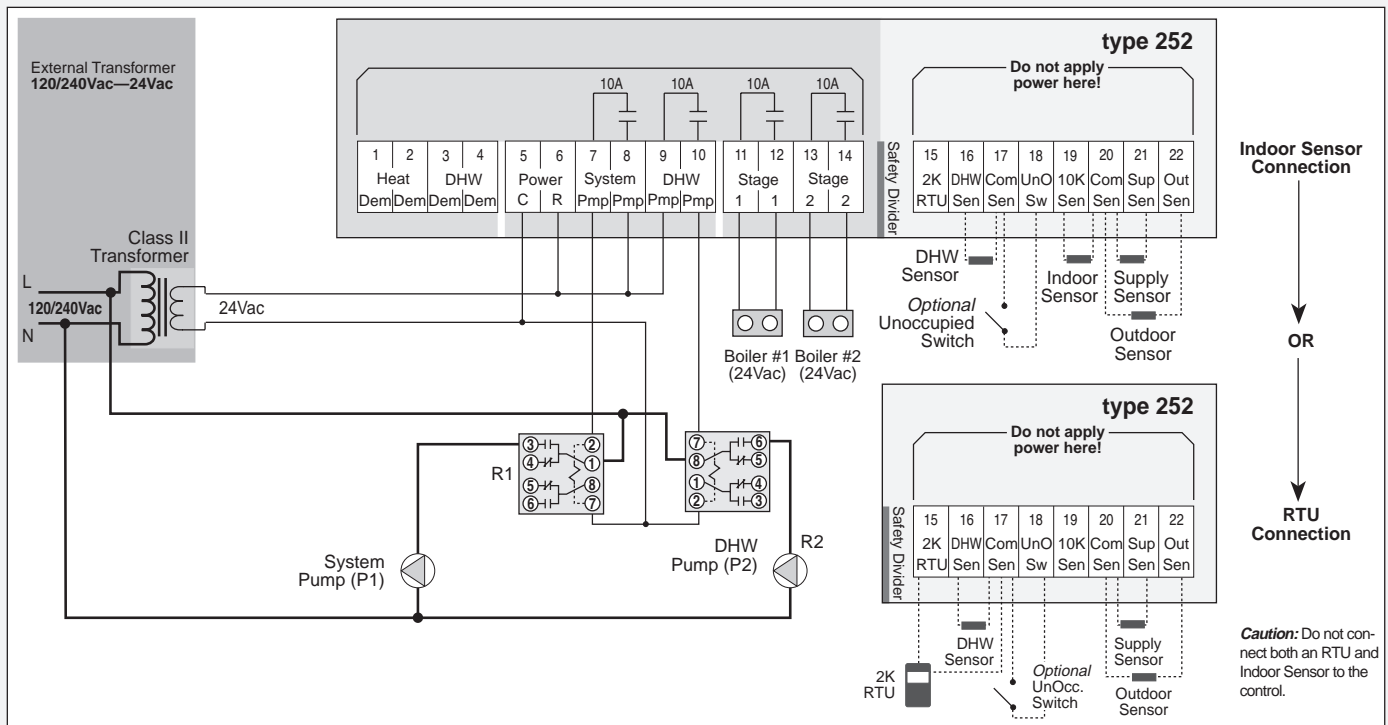

Note: This is only a concept drawing. Designers must determine whether this system will work in each application and must ensure compliance with code requirements. Necessary auxiliary equipment and safety devices must be added.

Specifications

The following are minimum recommended specifications for the control in this application.

- The heating system supply water temperature shall be based on the outdoor and indoor air temperatures, the control's Heating Curve (reset ratio), the Occupied (Unoccupied when in setback) dial settings or the DHW requirements.
- The indoor air temperature shall be measured by an Indoor Sensor 074 and be adjusted at the control's Occupied and Unoccupied dials or measured and adjusted by a Room Temperature Unit (RTU).
- The control shall have an Unoccupied (setback) switch or timer input to enable the control's Unoccupied temperature dial when an Indoor Sensor 074 is used.
- The system pump (P1) and the boiler shall be turned off whenever the outdoor air temperature is warmer than the control's Warm Weather Shut Down (WWSD) point, unless DHW is required.
- When DHW is required, the DHW pump (P2) shall be turned on and the boiler(s) fired to supply heat to the DHW tank based on the DHW dial setting or the requirements of the heating system, whichever is highest.
- The control shall have a selector switch to allow simultaneous or priority operation of the system and DHW pumps.
- The control shall have a switch to select whether or not DHW is to be generated during the Unoccupied time period.
- The control's WWSD point shall be based on the Occupied and Unoccupied temperature setting and the measured indoor air temperature when an Indoor Sensor 074 is used.
- If the indoor air temperature is rising above its setpoint, the WWSD temperature shall be lowered and if the indoor air temperature is falling below its setpoint, the WWSD temperature shall rise.
- During WWSD, the system pump (P1) shall be operated 20 seconds every 3 days to prevent seizure during long idle periods.
- The control shall have an adjustable Minimum Supply water temperature setting to help prevent condensation of flue gases and subsequent corrosion and blockage of the boiler heat exchangers and chimneys.
- In warmer weather the boiler(s) shall be cycled at the Minimum Supply temperature in order to maintain the selected indoor air temperature.
- The control shall have an adjustable Boiler Differential and shall calculate time delay between boiler cycles and stages to prevent short operating cycles of the boiler(s).
- The options for rotation shall be based on the boiler's running time.
- The control shall continuously monitor its temperature sensors and provide a LED error message when one is shorted or disconnected.
- The control shall be microprocessor-based, have 10 Amp relay contacts and have indicator lights for control function and status.
- The control shall have a test button which activates a pre-programmed test sequence to test all sensors and control outputs.
- The control enclosure shall be compatible with standard North American wiring hardware.
- The control shall be installed in an environment that is within the specified temperature and humidity ranges. The installer must ensure that the control and its wiring are isolated and/or shielded from strong sources of electromagnetic noise.
- The control system components required from tekmar are; Two Stage Boiler & DHW Control 252, an Universal Sensor 071, an Indoor Sensor 074 or a tekmar RTU 305, 307, 308 or 310.

Settings

Two Stage Boiler & DHW Control 252

	Adjustment Range
Occupied	35 to 105°F (2 to 41°C)
Unoccupied	35 to 105°F (2 to 41°C)
Heating Curve	0.4 to 3.6
DHW Supply	80 to 200°F (27 to 93°C)
Minimum Supply	Off, 80 to 170°F (27 to 77°C)
Boiler Differential	2 to 42°F (1 to 23°C)

Recommended Initial Settings

Two Stage Boiler & DHW Control 252 DIP switch settings for this application.

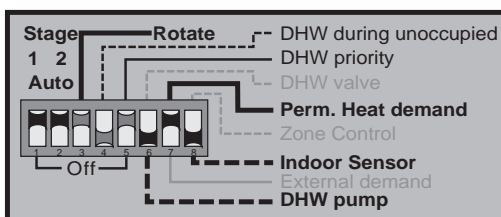

= required setting for this application.



= optional setting for this application.



= does not matter, switch not used for this application.

(see Data Brochure D 252)

Additional Information

- For control installation, testing and operating instructions see Brochure D 001 and D 252.
- For other control applications see Application Register A 000.
- For control theory and system integration details see E 001 and E 002.



tekmar® - Application

Two Stage Boiler & DHW Control 252

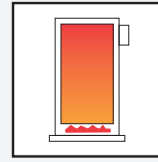
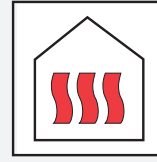
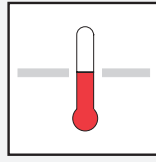

A 252-3

11/97

The Two Stage Boiler & DHW Control 252 regulates the heating system supply water temperature based on the outdoor air temperature by cycling the boilers on and off. The heating system is zoned with zone valves and Domestic Hot Water (DHW) is generated using a 2-way DHW valve.

Mechanical

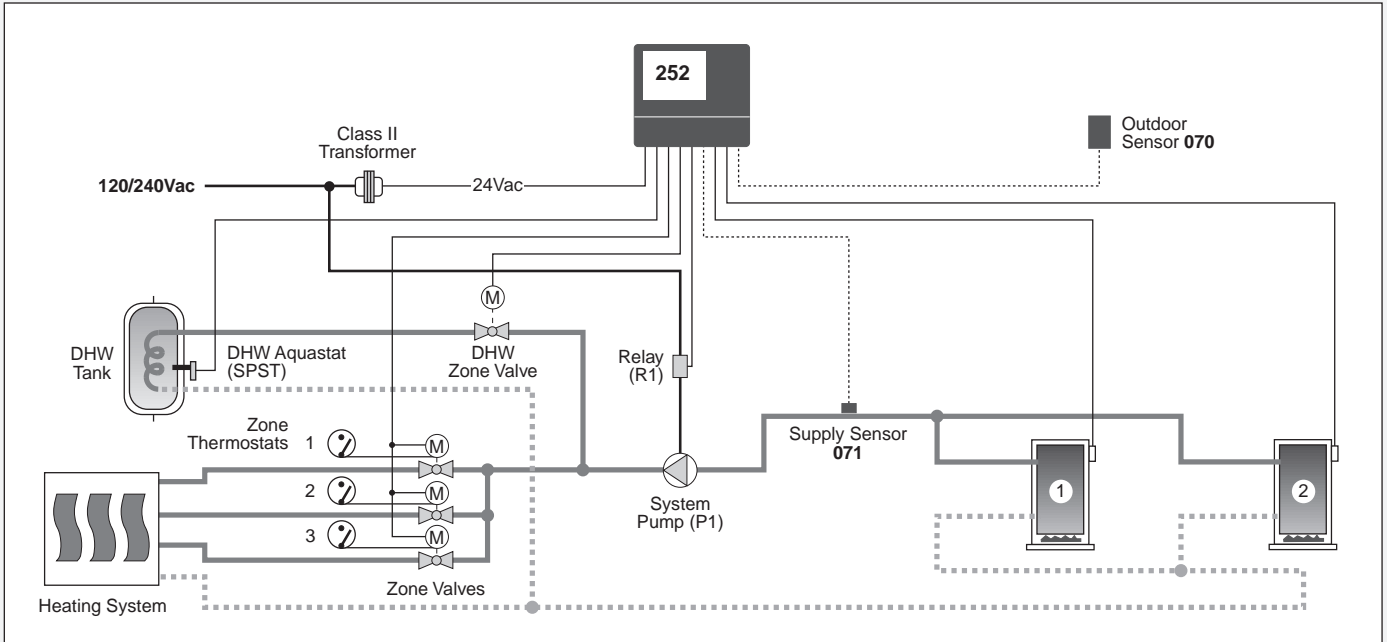

Electrical

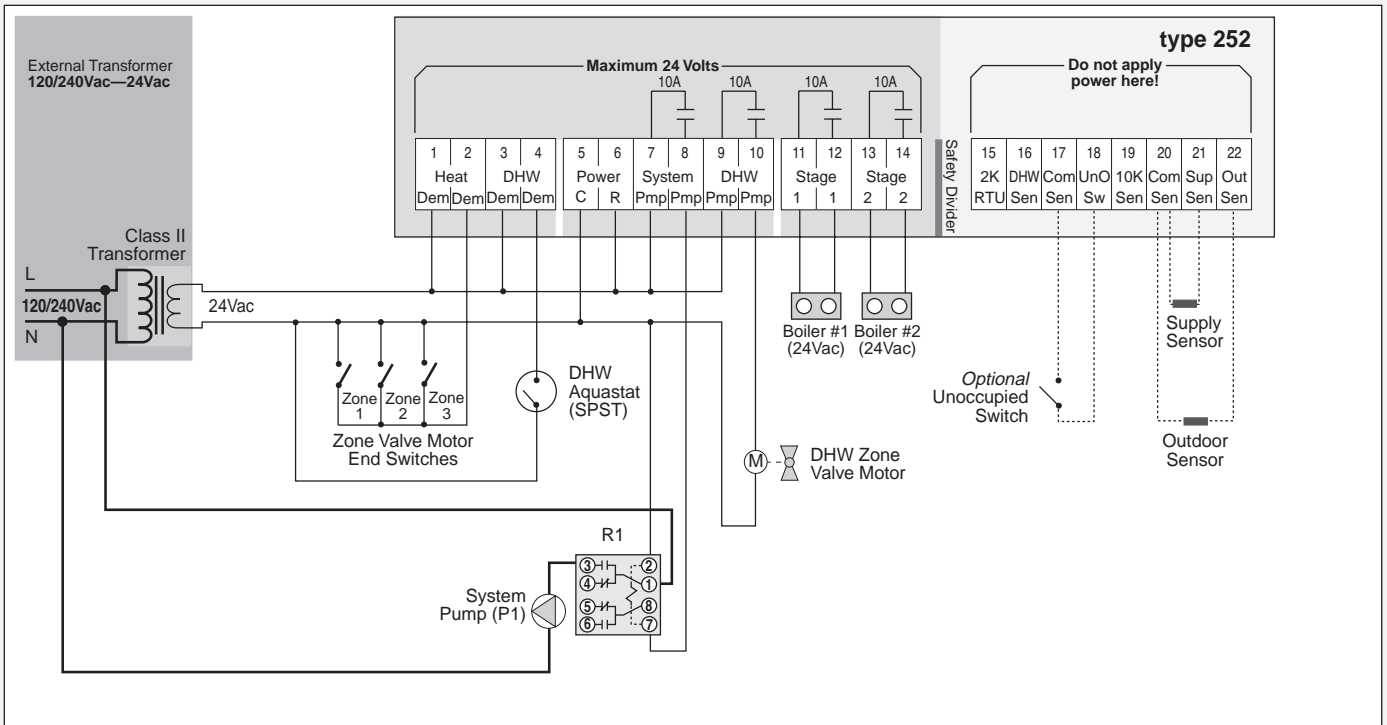

Note: This is only a concept drawing. Designers must determine whether this system will work in each application and must ensure compliance with code requirements. Necessary auxiliary equipment and safety devices must be added.

Specifications

The following are minimum recommended specifications for the control in this application.

- The heating system supply water temperature shall be based on the outdoor air temperature and the control's Heating Curve (reset ratio) and Occupied or Unoccupied (when in setback) dial settings.
 - The control shall have an Unoccupied (setback) switch or timer input to enable the control's Unoccupied temperature dial.
 - The pump and the boiler(s) shall be turned off until there is a "call for heat" from the zone valve motor end switches and the outdoor air temperature is colder than the control's Warm Weather Shut Down (WWSD) point or there is a "call for DHW" from the DHW aquastat.
 - The Occupied or Unoccupied temperature dial setting shall be the control's WWSD point.
 - During WWSD, the system pump (P1) shall be operated for 20 seconds every 3 days to prevent seizure during long idle periods.
 - The control shall have an adjustable Minimum Supply water temperature setting to help prevent condensation of flue gases and subsequent corrosion and blockage of boiler heat exchangers and chimneys.
 - The control shall have an adjustable Boiler Differential and shall calculate time delay between boiler cycles and stages to prevent short operating cycles of the boiler(s).
 - The options for rotation shall be based on the boiler's running time.
 - On a "call for DHW" the system pump (P1) shall be turned on, the DHW valve shall be opened and the boiler(s) controlled to provide supply water that is at least as hot as the setting of the DHW dial on the control.
 - The control shall have a switch to select whether or not DHW is to be generated during the Unoccupied time period.
 - The control shall continuously monitor its temperature sensors and provide a LED error message when one is shorted or disconnected.
 - The control shall be microprocessor-based, have 10 Amp relay contacts and have indicator lights for control function and status.
 - The control shall have a test button which activates a pre-programmed test sequence to test all sensors and control outputs.
 - The control enclosure shall be compatible with standard North American wiring hardware.
 - The control shall be installed in an environment that is within the specified temperature and humidity ranges. The installer must ensure that the control and its wiring are isolated and/or shielded from strong sources of electromagnetic noise.
- The control system component required from tekmar is a Two Stage Boiler & DHW Control 252.

Settings

Two Stage Boiler & DHW Control 252

	Adjustment Range
Occupied	35 to 105°F (2 to 41°C)
Unoccupied	35 to 105°F (2 to 41°C)
Heating Curve	0.4 to 3.6
DHW Supply	80 to 200°F (27 to 93°C)
Minimum Supply	Off, 80 to 170°F (27 to 77°C)
Boiler Differential	2 to 42°F (1 to 23°C)

Recommended Initial Settings

Two Stage Boiler & DHW Control 252 DIP switch settings for this application.

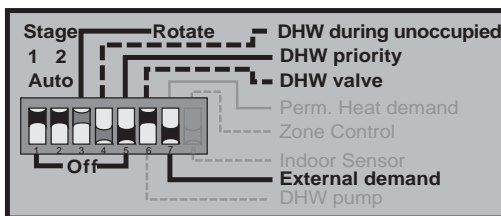

 = required setting for this application.

 = optional setting for this application.

 = does not matter, switch not used for this application.

(see Data Brochure D 252)

Additional Information

- For control installation, testing and operating instructions see Brochure D 001 and D 252.
- For other control applications see Application Register A 000.
- For control theory and system integration details see E 001 and E 002.



tekmar® - Application

Two Stage Boiler & DHW Control 252

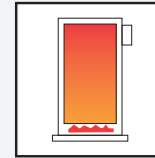
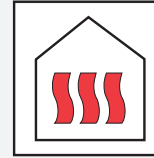
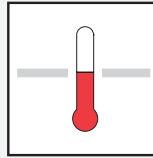

A 252-4

11/97

The Two Stage Boiler & DHW Control 252 regulates the heating system supply water temperature based on the outdoor air temperature by cycling the boilers on and off. The heating system is zoned using zone pumps. Domestic Hot Water temperature is measured by a DHW sensor 071 (**ordered separately**). DHW generation uses a pump, and can have priority over space heating.

Mechanical

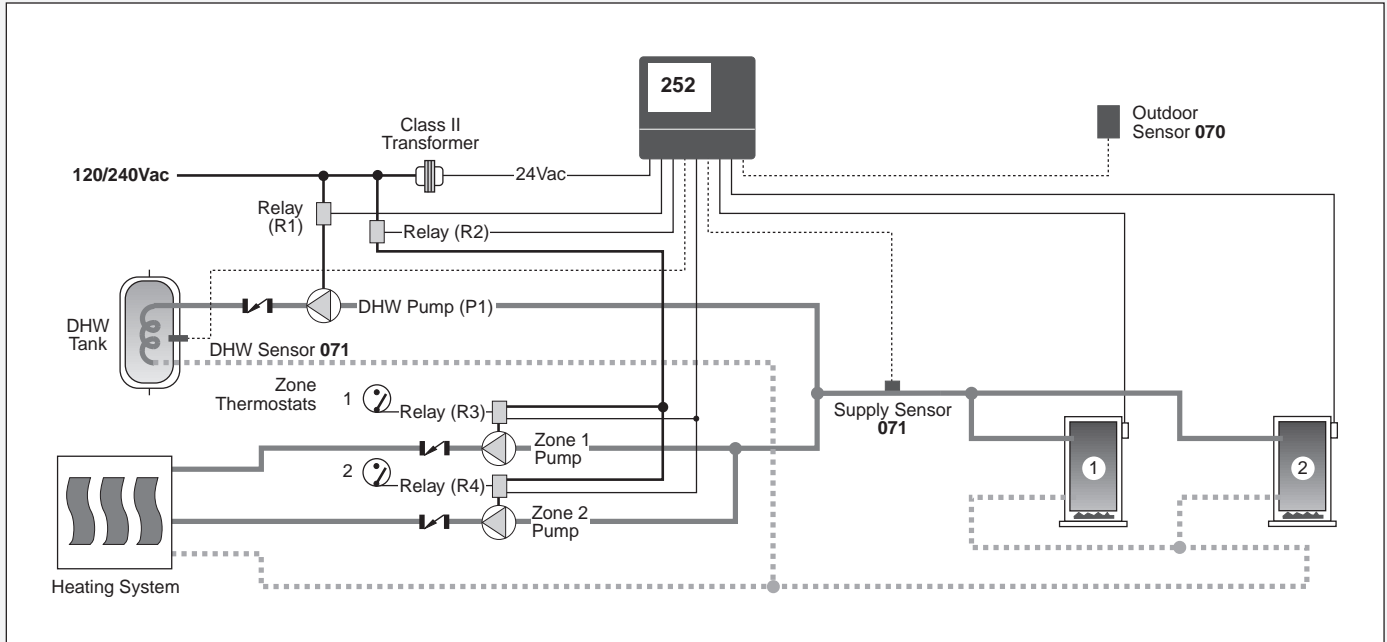

Electrical

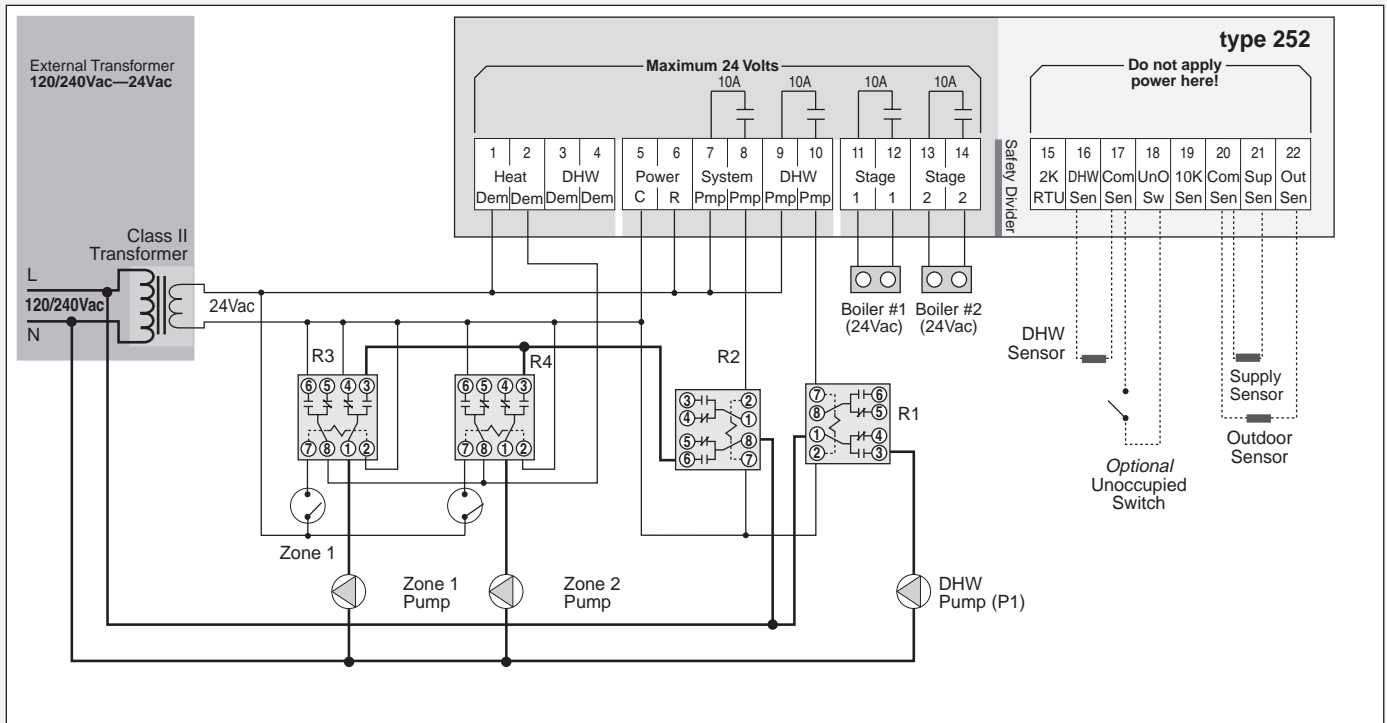

Note: This is only a concept drawing. Designers must determine whether this system will work in each application and must ensure compliance with code requirements. Necessary auxiliary equipment and safety devices must be added.

Specifications

The following are minimum recommended specifications for the control in this application.

- The heating system supply water temperature shall be based on the outdoor air temperature and the control's Heating Curve (reset ratio) and Occupied or Unoccupied (when in setback) dial settings.
- The control shall have an Unoccupied (setback) switch or timer input to enable the control's Unoccupied temperature dial.
- The pumps and boilers shall be turned off until there is a "call for heat" from the zone pump relays and the outdoor air temperature is colder than the control's Warm Weather Shut Down (WWSD) point or there is a "call for DHW" from the DHW Sensor 071.
- The Occupied or Unoccupied temperature dial setting shall be the control's WWSD point.
- During WWSD, if a zone thermostat is closed, that Zone pump shall be operated for 20 seconds every 3 days to prevent seizure during long idle periods.
- The control shall have an adjustable Minimum Supply water temperature setting to help prevent condensation of flue gases and subsequent corrosion and blockage of the boiler heat exchangers and chimneys.
- The control shall have an adjustable Boiler Differential and shall calculate time delay between boiler cycles and stages to prevent short operating cycles of the boiler(s).
- The options for rotation shall be based on the boiler's running time.
- On a "call for DHW" the zone pumps shall be turned off, the DHW pump (P1) shall be turned on and the boilers controlled to provide supply water at least 20°F hotter than the DHW temperature. The DHW tank temperature shall be adjustable by a DHW dial on the control.
- The control shall have a switch to select whether or not DHW is to be generated during the Unoccupied time period.
- The control shall continuously monitor its temperature sensors and provide a LED error message when one is shorted or disconnected.
- The control shall be microprocessor-based, have 10 Amp relay contacts and have indicator lights for control function and status.
- The control shall have a test button which activates a pre-programmed test sequence to test all sensors and control outputs.
- The control enclosure shall be compatible with standard North American wiring hardware.
- The control shall be installed in an environment that is within the specified temperature and humidity ranges. The installer must ensure that the control and its wiring are isolated and/or shielded from strong sources of electromagnetic noise.
- The control system components required from tekmar are; Two Stage Boiler & DHW Control 252 and a Universal Sensor 071.

Settings

Two Stage Boiler & DHW Control 252

Occupied
Unoccupied
Heating Curve
DHW Supply
Minimum Supply
Boiler Differential

Adjustment Range

35 to 105°F (2 to 41°C)
35 to 105°F (2 to 41°C)
0.4 to 3.6
80 to 200°F (27 to 93°C)
Off, 80 to 170°F (27 to 77°C)
2 to 42°F (1 to 23°C)

Recommended Initial Settings

Two Stage Boiler & DHW Control 252 DIP switch settings for this application.

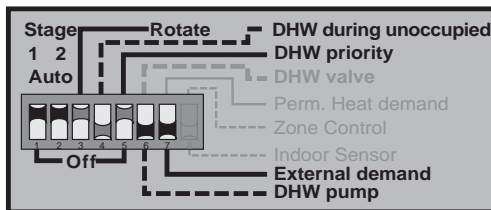

- = required setting for this application.
- = optional setting for this application.
- = does not matter, switch not used for this application.

(see Data Brochure D 252)

Additional Information

- For control installation, testing and operating instructions see Brochure D 001 and D 252.
- For other control applications see Application Register A 000.
- For control theory and system integration details see E 001 and E 002.

In North America: tekmar Control Systems Ltd., Canada
tekmar Control Systems, Inc., U.S.A.
Head Office: 4611 - 23rd Street
Vernon, B.C. Canada V1T 4K7
Tel. (604) 545-7749 Fax. (604) 545-0650

tekmar® - Application

Two Stage Boiler & DHW Control 252

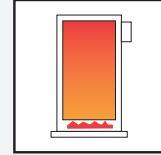

A 252-5

12/96

Mechanical

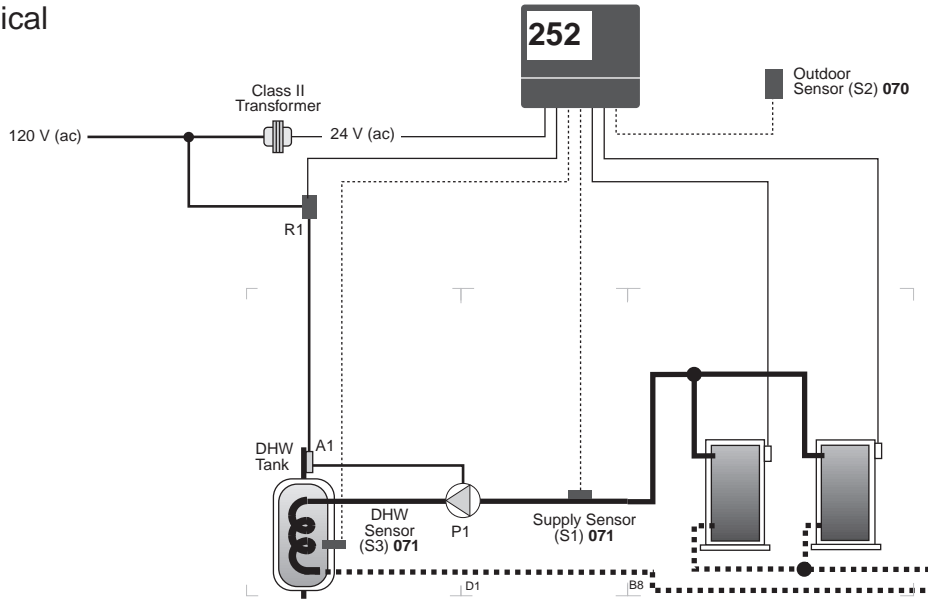

Note The application requires control with a Date Code of May '96 or newer

Electrical

- A1 = DHW High Limit Aquastat
- P1 = DHW Pump
- R1 = Relay 003
- S1 = Supply Sensor 071
- S2 = Outdoor Sensor 070
- S3 = DHW Sensor 071

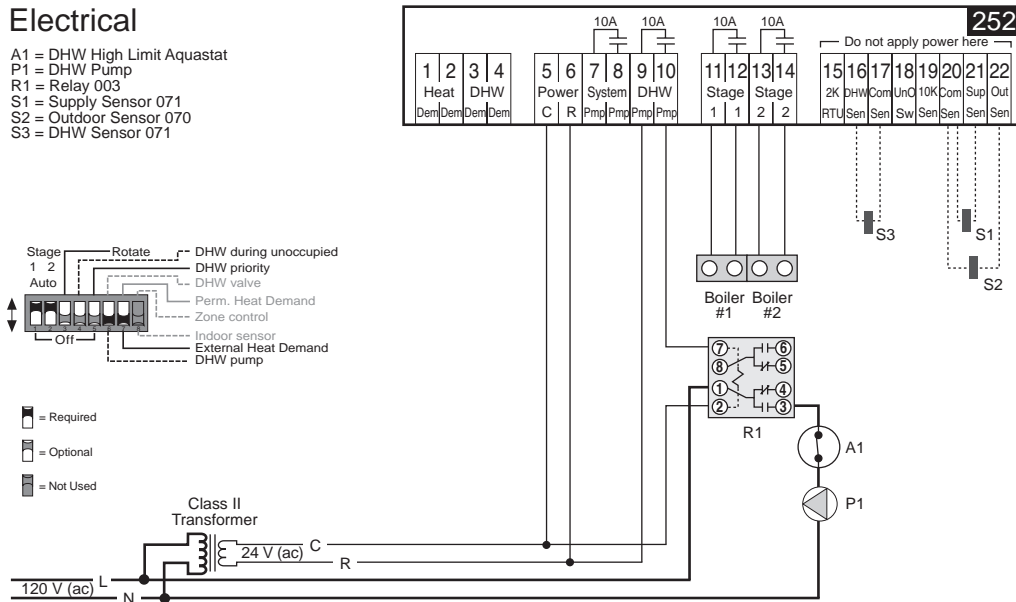

Note: This is only a concept drawing. The designer must determine whether this application will work in his system and must ensure compliance with code requirements. Necessary auxiliary equipment, isolation relays (for loads greater than the specified tekmar internal relay ratings), and other safety and limit devices must be added.

Technical Data

Two Stage Boiler & DHW Control 252

- Literature — A 000, A 252's, D 252, D 001, D 05, D 06, D 070, D 074
- Control — Microprocessor PID control; This is **not a safety (limit) control**.
- Packaged weight — 2.9 lb. (1300 g), Enclosure A, PVC plastic
- Dimensions — 6-5/8" H x 7-9/16" W x 2-13/16" D (170 x 193 x 72 mm)
- Approvals — Meets ICES & FCC regulations for EMI/RFI.
- Ambient conditions — Indoor use only, 30 to 120°F (0 to 50°C), < 95% RH non-condensing.
- Power supply — Class 2, 24 V (ac) ±10% 50/60 Hz 3 VA
- Relay capacity — 24 V (ac) 10 A, pilot duty 240 VA 2 A
- Sensors — NTC thermistor, 10 kΩ @ 77°F (25°C ±0.2°C) β=3892
 included: Outdoor Sensor 070 and Universal Sensor 071.
 optional: Universal Sensor 071, 10K Indoor Sensor or 2k RTU.
- Occupied — 35 to 105°F (2 to 41°C)
- Unoccupied — 35 to 105°F (2 to 41°C)
- Heating Curve — 0.4 to 3.6
- DHW temperature — 80 to 200°F (27 to 93°C)
- Minimum Supply — Off, 80 to 170°F (Off, 27 to 77°C)
- Boiler Differential — 2 to 42°F (1 to 23°C)

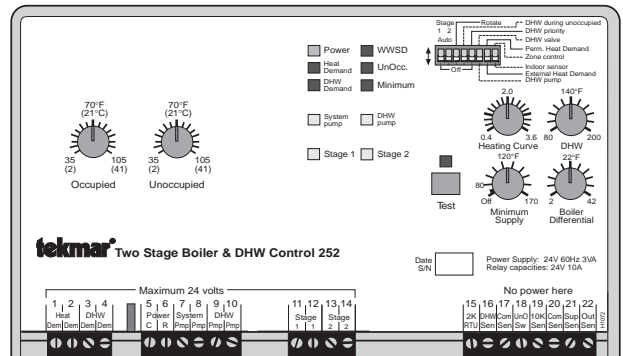

System Operation & Specifications

The Two Stage Boiler and Domestic Hot Water Control 252 controls two boilers to provide heat to an indirect hot water storage tank.

Piping and Heat Source Details The two boilers are piped in reverse return providing equal flow through each boiler. This is a dedicated system with the only load being an indirect hot water storage tank.

Boiler Operation In this application, the 252 is used as a staging and rotation control in order to maintain a fixed DHW tank temperature. Through the use of the DHW sensor, the 252 maintains the DHW tank at the *DHW* dial setting. This is accomplished by providing a supply water temperature 20°F to 40°F above the *DHW* dial setting depending on the demand for DHW. On a call for DHW, the 252 closes its *DHW Pump* contacts and enables the DHW pump (P1) in order to provide circulation through the DHW tank's coil. The 252 then stages the boilers using PID logic based on the supply water temperature. For additional information on PID logic and Equal Run Time Rotation, refer to Application Catalog A 000 and Data Brochure D 252. *Note:* Even though the 252 is not being used as a Reset Control, the Outdoor Sensor 070 (S2) must still be connected to terminals 20 and 21 in order for the control to function correctly.

Additional Functions Additional control functions are listed in the table in the Boiler / DHW section of the Product Catalog I 000 and the Application Catalog A 000.



tekmar Control Systems Ltd., Canada
 tekmar Control Systems, Inc., U.S.A.
Head Office: 4611 - 23rd Street
Vernon, B.C. Canada V1T 4K7
Tel. (250) 545-7749 Fax. (250) 545-0650