

# tekmar® - Application

## Multi-Stage Boiler Reset Control 233

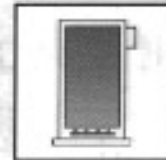

A 233-1

03/92

The Multi-Stage Boiler Reset Control 233 regulates the heating system supply water temperature based on the outdoor temperature by staging and cycling the four boilers. The boilers rotate based on running time. At an adjustable Warm Weather Shut Down (WWSD) temperature the system pump and boilers are turned off. The system pump is run continuously until WWSD. The Six Relay Expansion Module 235 can be added to control up to 10 boiler stages.

### Mechanical

**Note:** This is only a concept drawing. The designer must determine whether this system will work in his application and conform to code requirements. Necessary auxiliary equipment and safety devices must be added.

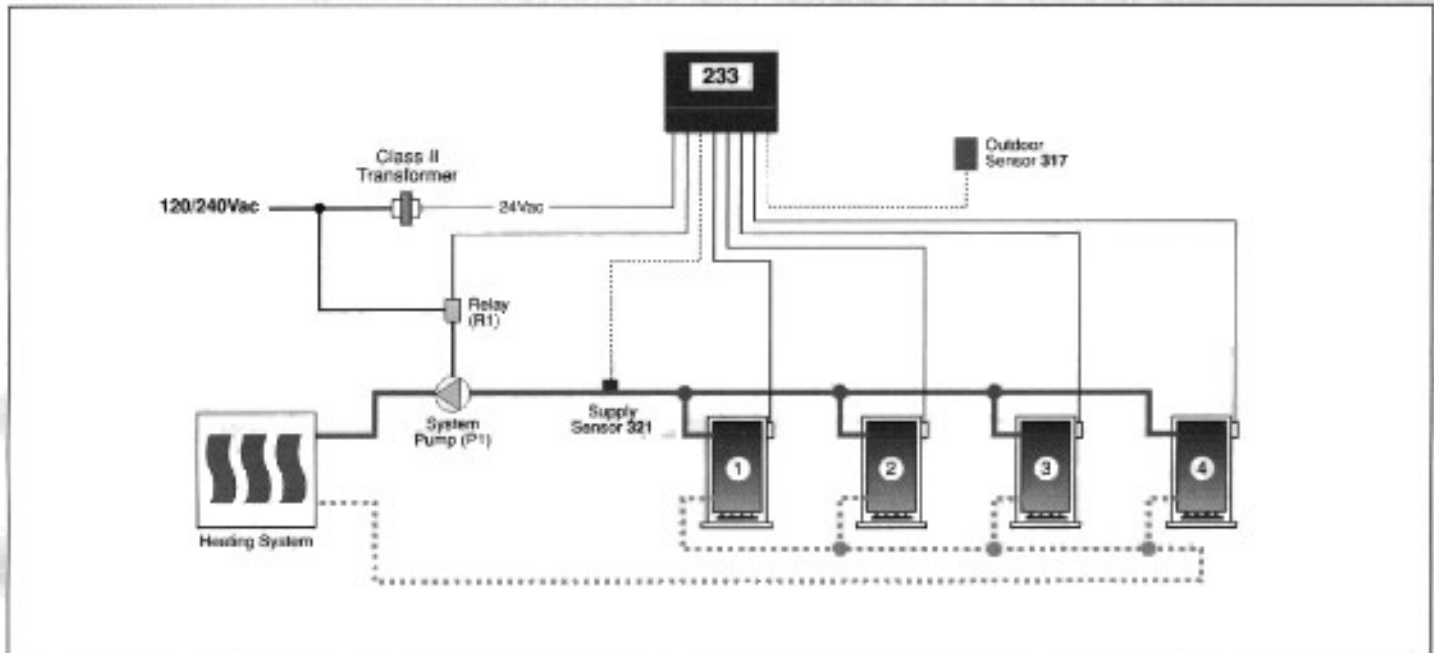

### Electrical

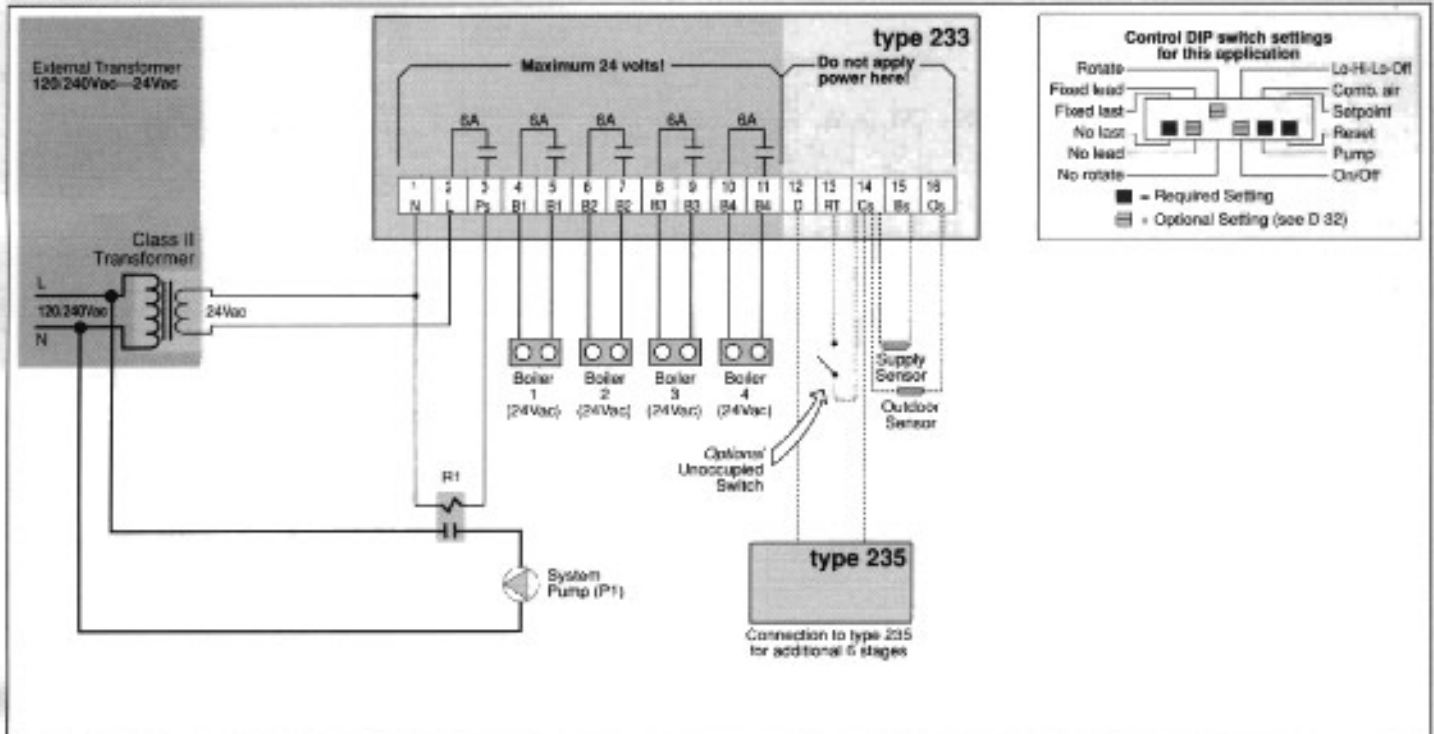

# tekmar® - Application

## Multi-Stage Boiler Reset Control 233

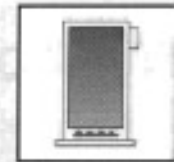

A 233-2

03/92

When any heating zone calls for heat the system pump is turned on and the Multi-Stage Boiler Reset Control 233 is enabled. The control then regulates the heating system supply water temperature based on the outdoor temperature by staging and cycling the four boilers. The boilers are rotated based on running time. The combustion air damper is opened when at least one boiler is turned on. When the outdoor temperature is higher than the Warm Weather Shut Down (WWSD) setting the boilers are turned off. The Six Relay Expansion Module 235 can be added to control up to 10 boiler stages.

### Mechanical

**Note:** This is only a concept drawing. The designer must determine whether this system will work in his application and conform to code requirements. Necessary auxiliary equipment and safety devices must be added.

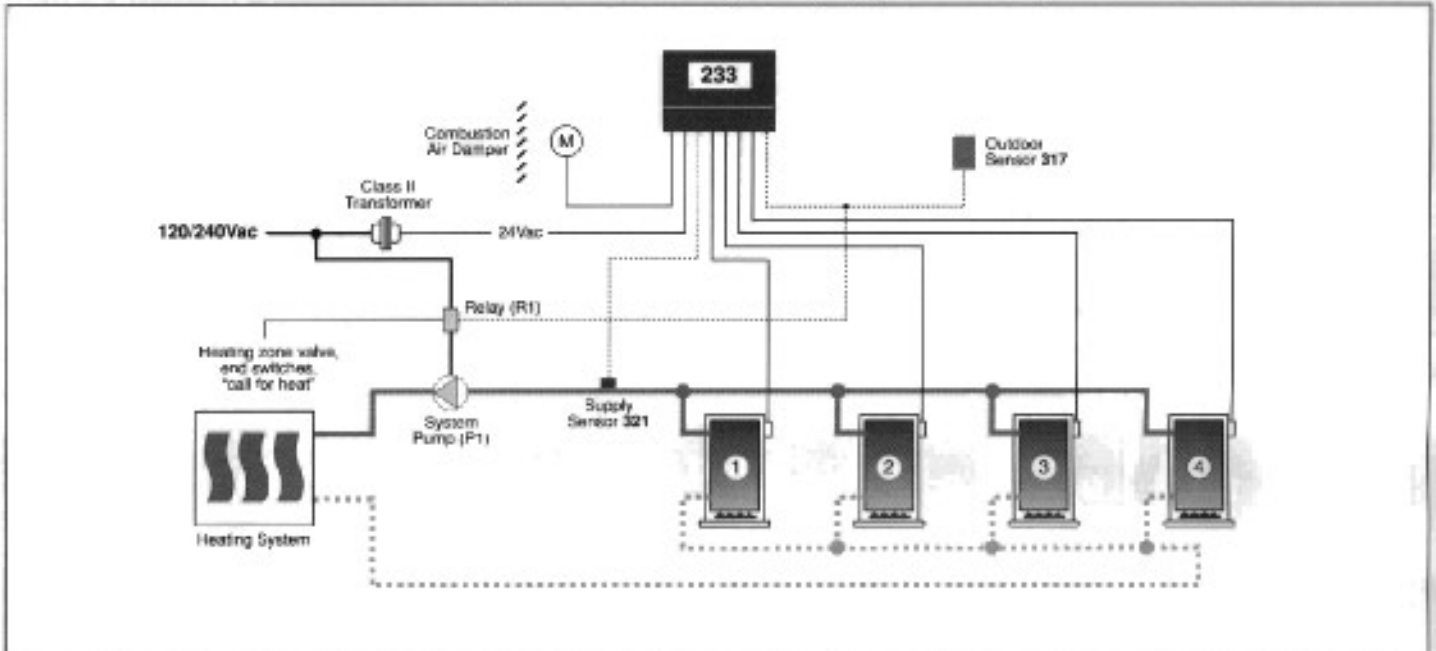

### Electrical

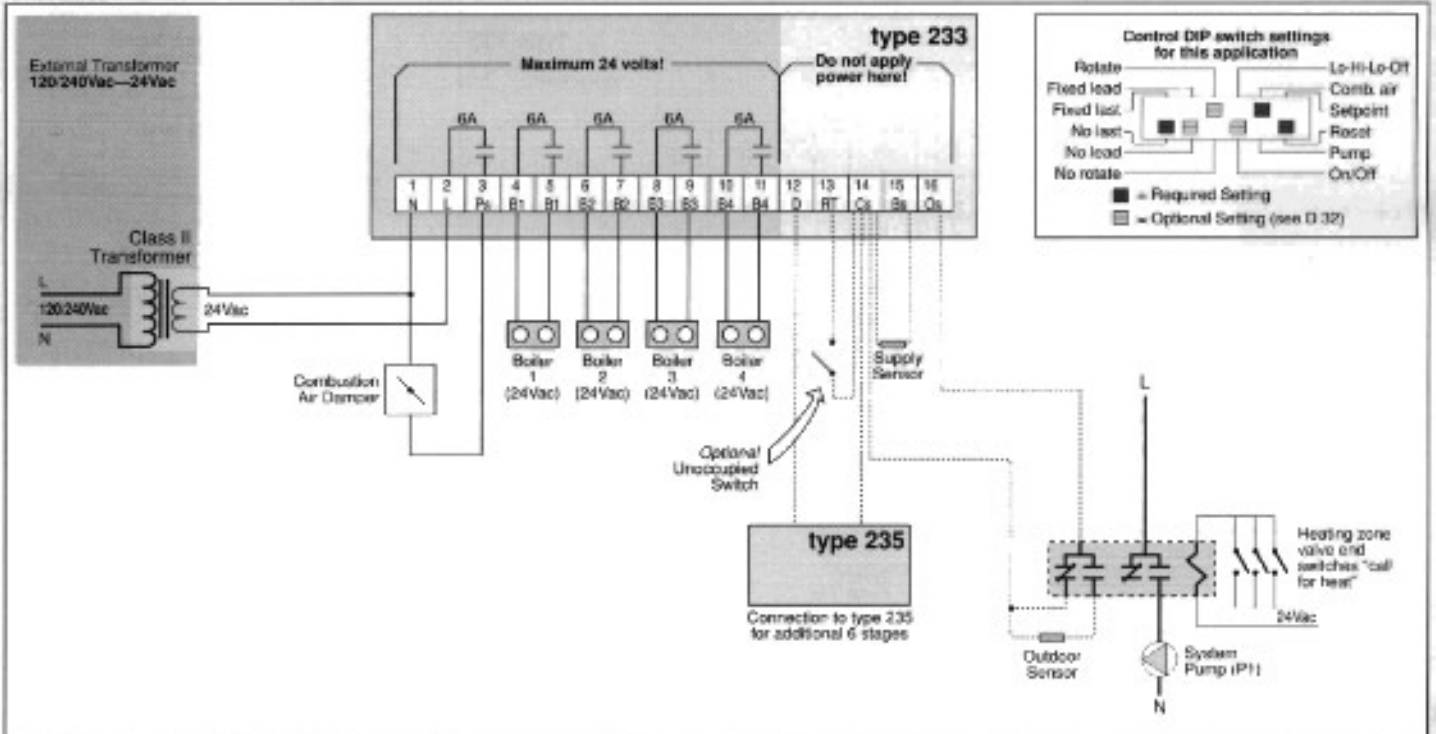

# tekmar® - Application

## Multi-Stage Boiler Reset Control 233

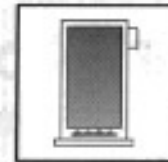

A 233-3

03/92

When any heating zone calls for heat the system pump is turned on and the type 233 is enabled. The control then regulates the heating system supply water temperature based on the outdoor temperature by staging and cycling the four boilers. The boilers are rotated based on running time. When DHW generation is required the system pump is turned off, the DHW pump is turned on and the control is switched into its setpoint mode. The combustion air damper is opened when at least one boiler is turned on. When the outdoor temperature is higher than the Warm Weather Shut Down setting the boilers are turned off. The Six Relay Expansion Module 235 can be added to control up to 10 boiler stages.

**Note:** This is only a concept drawing. The designer must determine whether this system will work in his application and conform to code requirements. Necessary auxiliary equipment and safety devices must be added.

### Mechanical

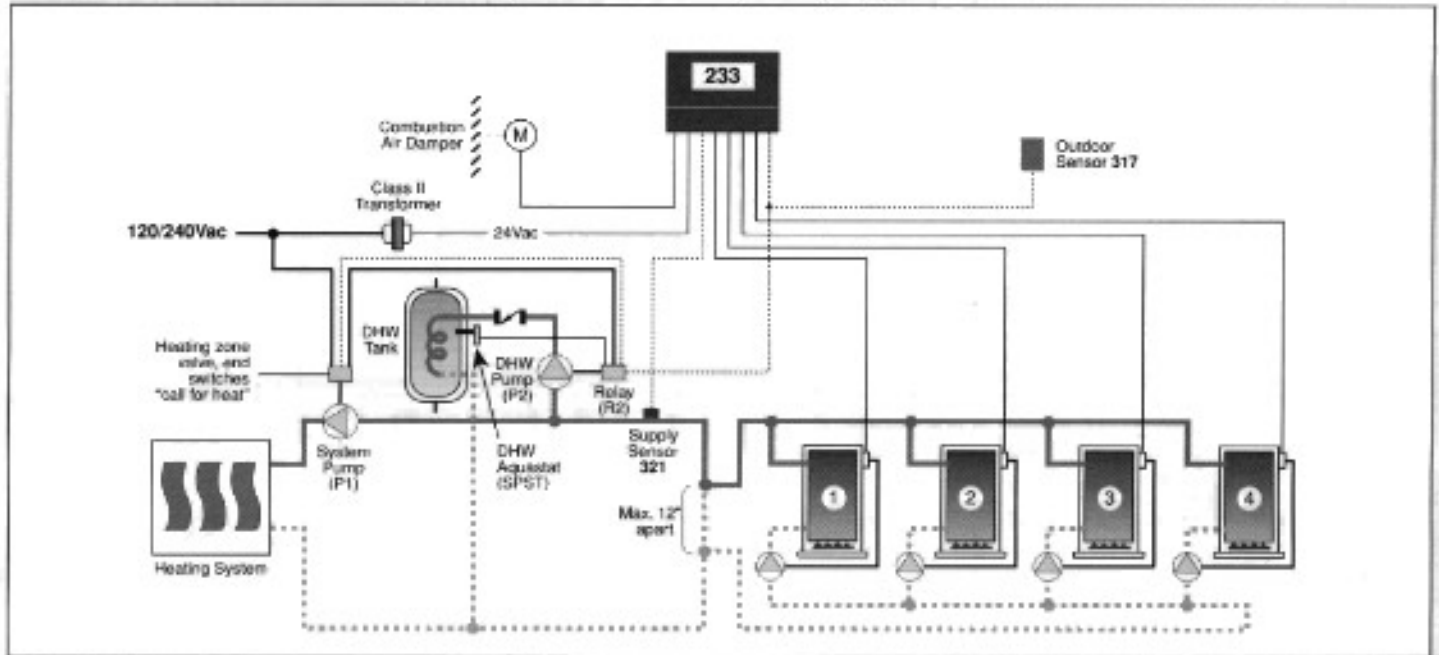

### Electrical

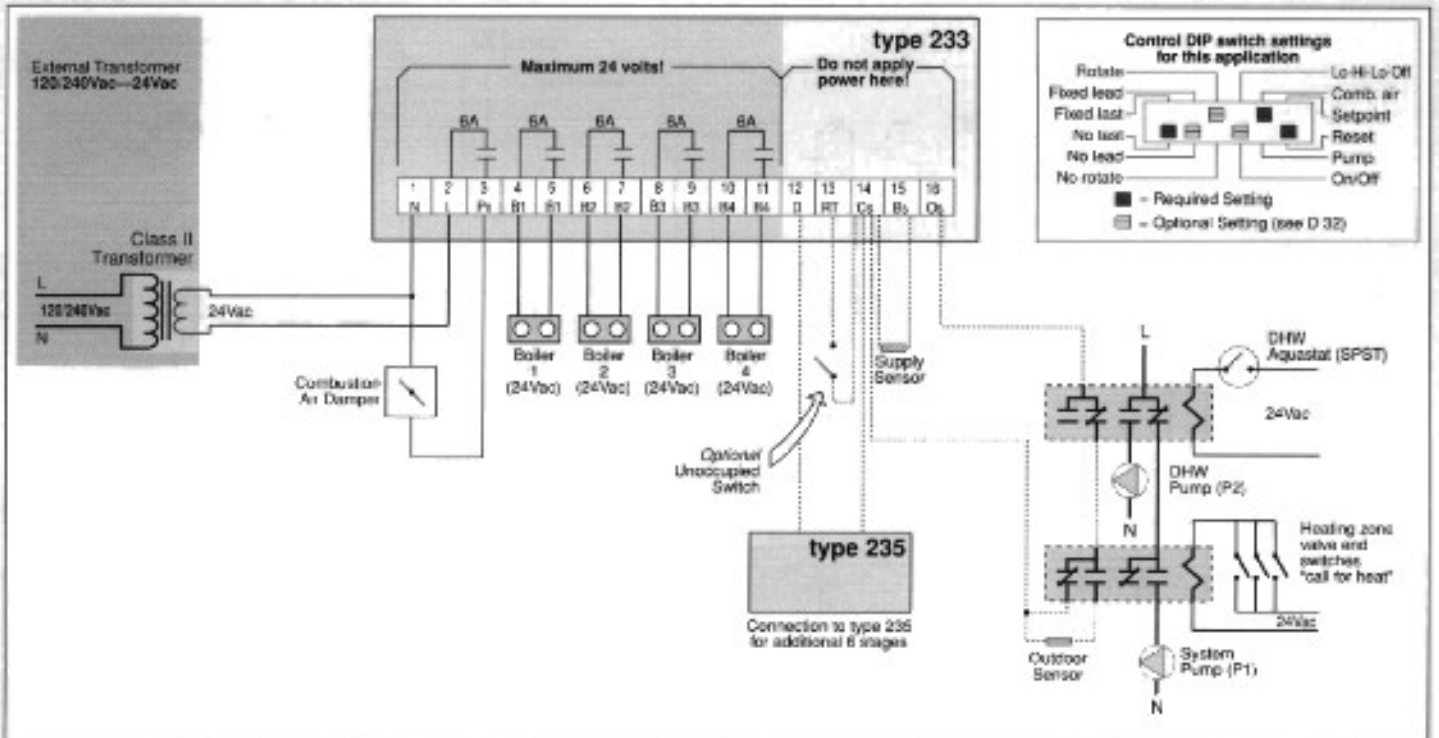

# tekmar® - Application

## Multi-Stage Boiler Reset Control 233

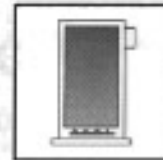
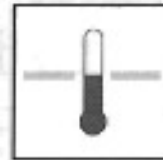

A 233-4

03/92

When any heating zone calls for heat, the system pump is turned on and the Multi-Stage Boiler Reset Control 233 is enabled. The control then regulates the heating system supply water temperature based on the outdoor temperature by staging and cycling the four boilers. The boilers are rotated based on running time. When DHW generation is required, boiler 4 and the DHW pump are turned on. At maximum heat load conditions and if no DHW is required, the heating assist valve opens and diverts water from boiler 4 to the heating system. The combustion air damper is opened when at least one boiler is turned on. When the outdoor temperature is higher than the Warm Weather Shut Down (WWSD) setting, the boilers are turned off.

**Note:** This is only a concept drawing. The designer must determine whether this system will work in his application and conform to code requirements. Necessary auxiliary equipment and safety devices must be added.

### Mechanical

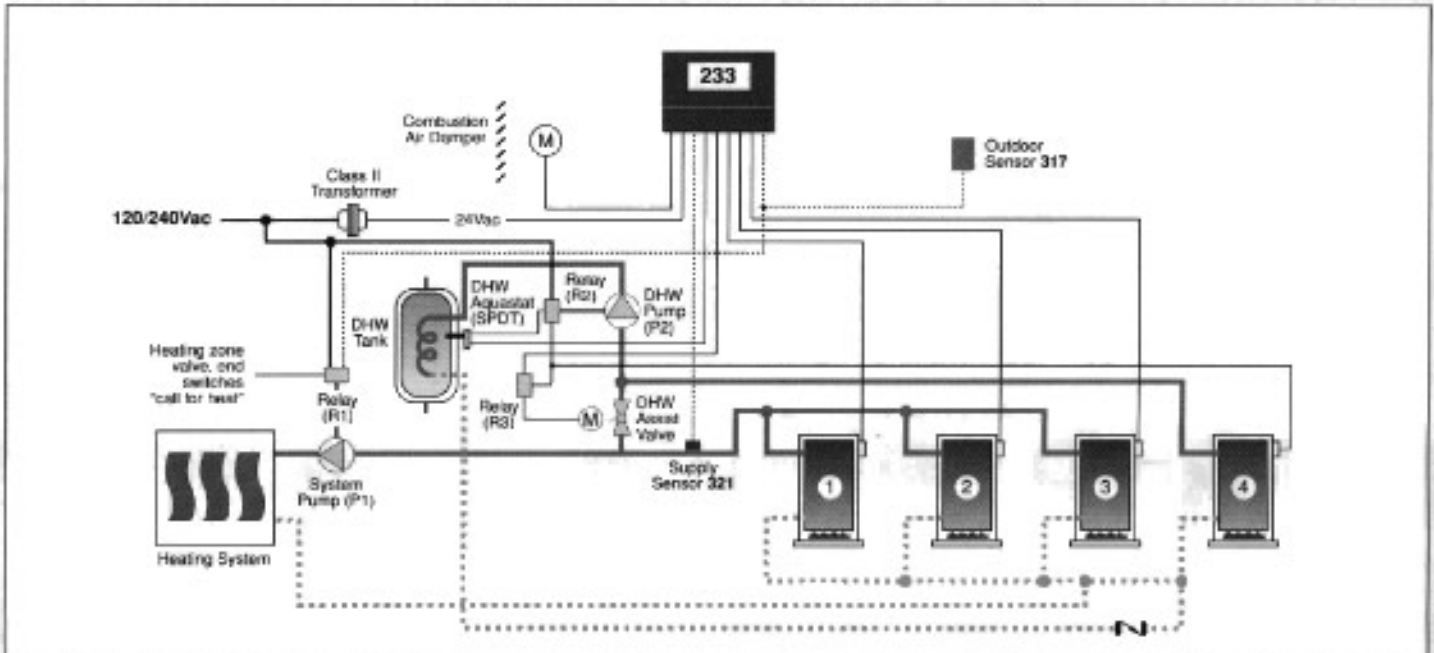

### Electrical

