

- A1 = DHW Aquastat
- C1 = Actuating Motor 011
- P1 = Boiler Pump
- R1 = Relay 003
- S1 = Mix Supply Sensor 071
- S2 = Boiler Supply Sensor 071
- S3 = Outdoor Sensor 070
- V1 = DHW Valve
- V2 = 4-Way Mixing Valve
- V3 = Balancing Valve or Pressure Bypass Valve
- Z1...Z3 = Mix Zone Pump

Concept Drawing

This is only a concept drawing, not an engineered drawing. It is not intended to describe a complete system, nor any particular system. It is up to the system designer to determine the necessary components for and configuration of the particular system being designed, including additional equipment, isolation relays (for loads greater than the control's specified output ratings), and any safety devices which in the judgement of the designer are appropriate, in order to properly size, configure and design that system and to ensure compliance with building and safety code requirements.

System Operation

XXXX

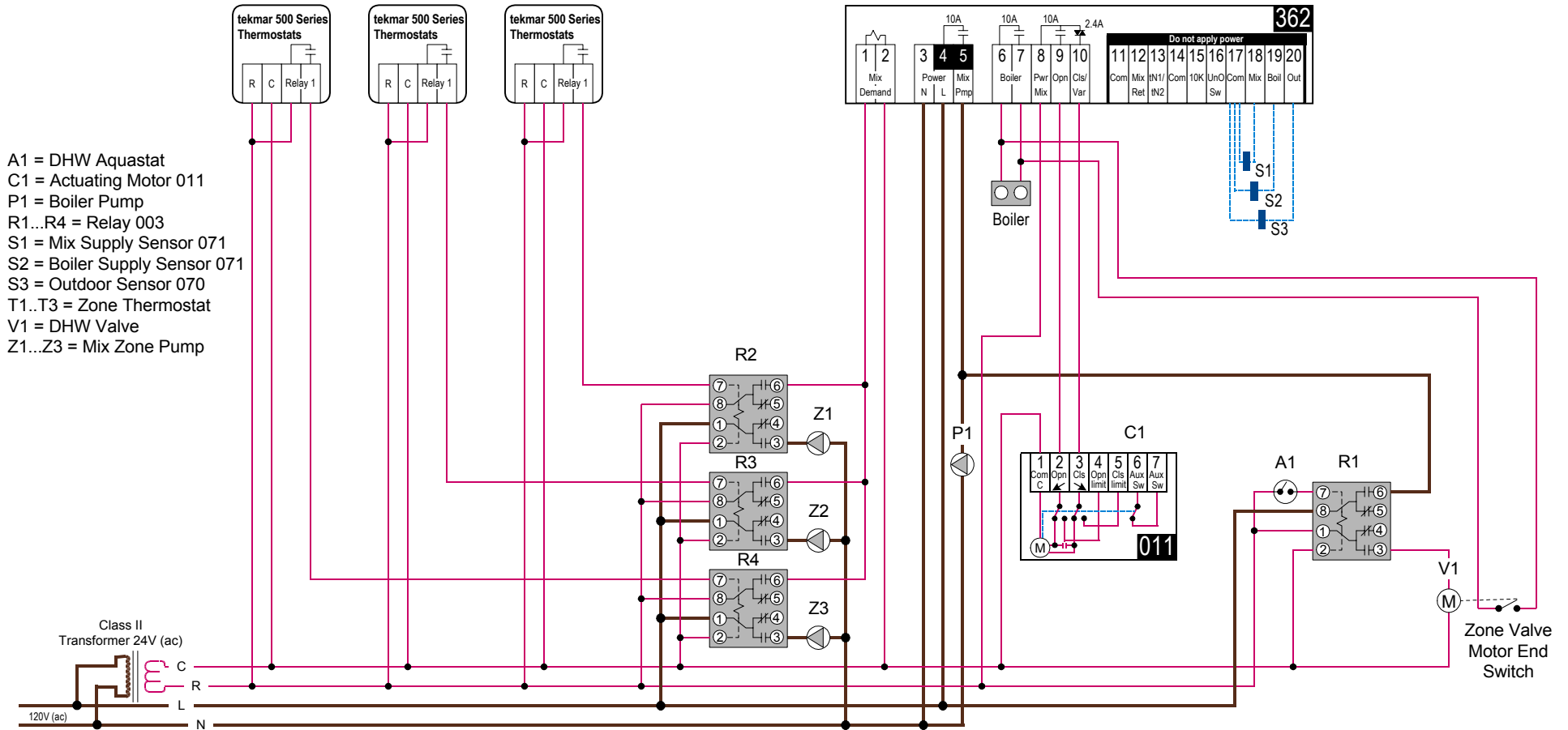

Concept Drawing

This is only a concept drawing, not an engineered drawing. It is not intended to describe a complete system, nor any particular system. It is up to the system designer to determine the necessary components for and configuration of the particular system being designed, including additional equipment, isolation relays (for loads greater than the control's specified output ratings), and any safety devices which in the judgement of the designer are appropriate, in order to properly size, configure and design that system and to ensure compliance with building and safety code requirements.

Essential Control Settings

XXXX