

#### Concept Drawing

This is only a concept drawing, not an engineered drawing. It is not intended to describe a complete system, nor any particular system. It is up to the system designer to determine the necessary components for and configuration of the particular system being designed, including additional equipment, isolation relays (for loads greater than the control's specified output ratings), and any safety devices which in the judgement of the designer are appropriate, in order to properly size, configure and design that system and to ensure compliance with building and safety code requirements.

#### System Operation

XXXX

- P1 = Boiler Pump
- P2, P4, P6 = Variable Speed Injection Pump
- P3, P5, P7 = Mix System Pumps
- S1, S4, S9 = Mix Supply Sensor 071
- S2, S5, S10 = Boiler Return Sensor 071
- S3, S6, S11 = Outdoor Sensor 070
- S7 = Slab Sensor 072/073
- S8 = Mix Return Sensor 071
- U1 = External Demand Switch
- Z1...Z4 = Mix Zones

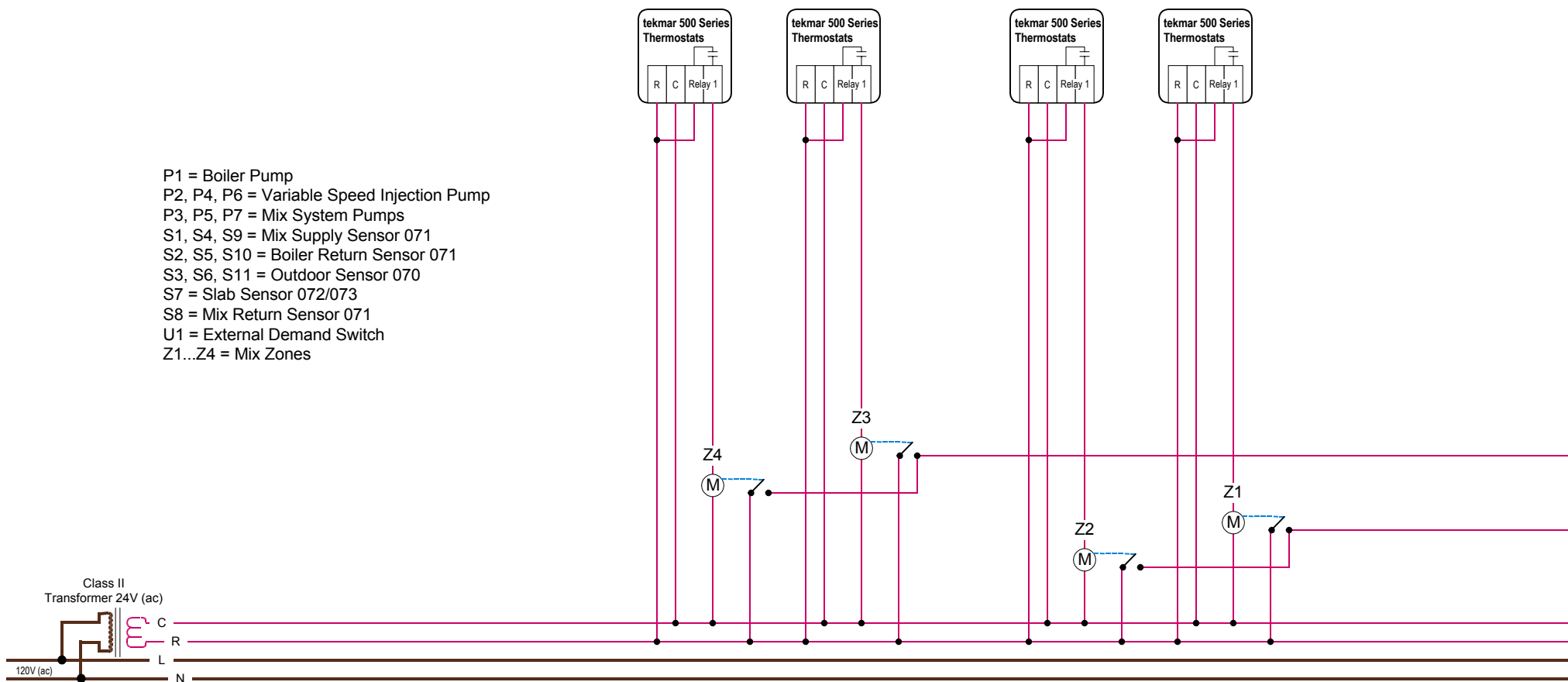

#### Concept Drawing

This is only a concept drawing, not an engineered drawing. It is not intended to describe a complete system, nor any particular system. It is up to the system designer to determine the necessary components for and configuration of the particular system being designed, including additional equipment, isolation relays (for loads greater than the control's specified output ratings), and any safety devices which in the judgement of the designer are appropriate, in order to properly size, configure and design that system and to ensure compliance with building and safety code requirements.

#### Essential Control Settings

XXXX

tekmar Control Systems Ltd., Canada; tekmar Control Systems, Inc., U.S.A.; [www.tekmarcontrols.com](http://www.tekmarcontrols.com)  
 Head Office: 4611-23rd Street, Vernon, B.C. Canada, V1T 4K7; (250)545-7749 Fax (250) 545-0650

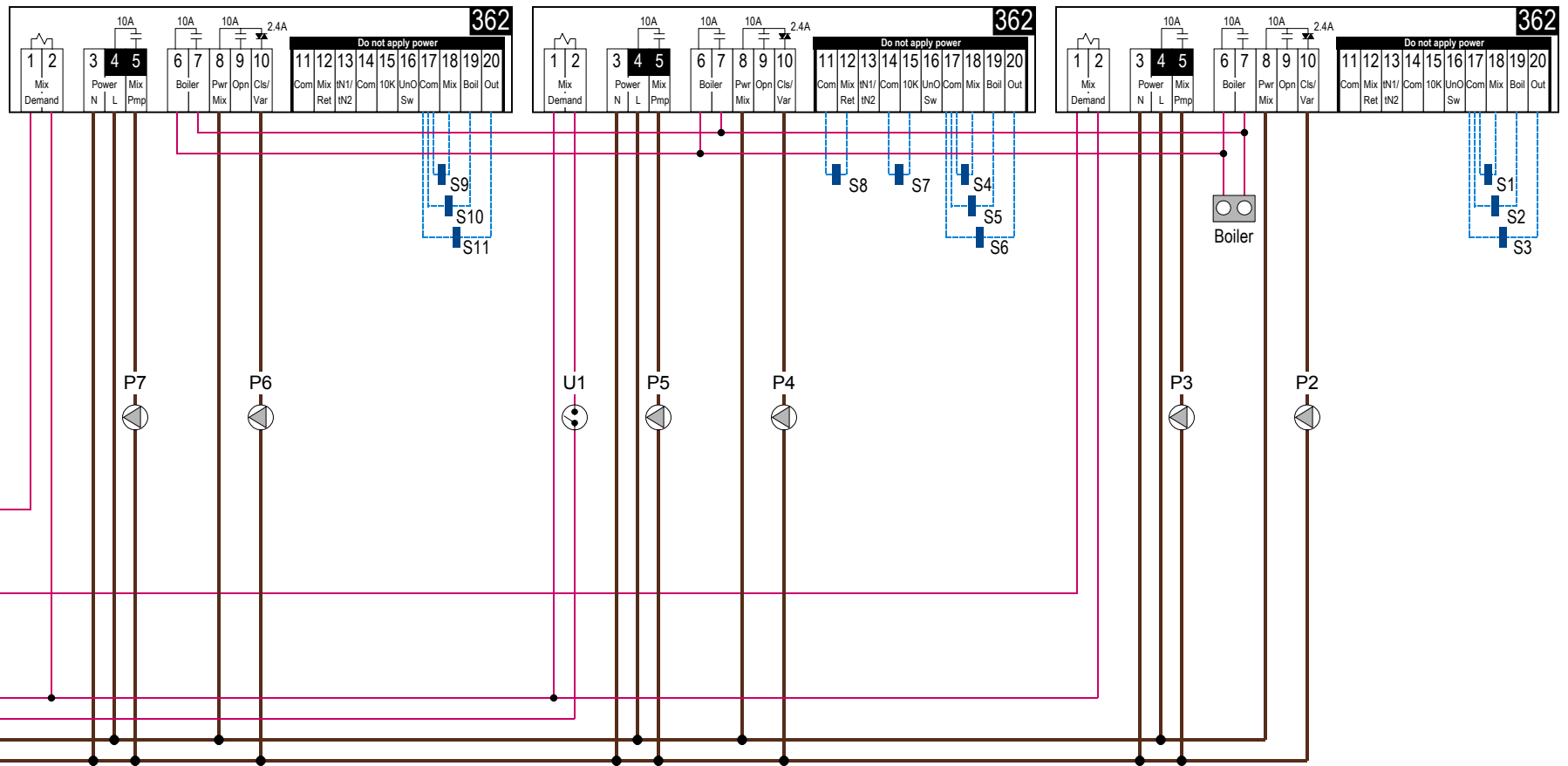

#### Concept Drawing

This is only a concept drawing, not an engineered drawing. It is not intended to describe a complete system, nor any particular system. It is up to the system designer to determine the necessary components for and configuration of the particular system being designed, including additional equipment, isolation relays (for loads greater than the control's specified output ratings), and any safety devices which in the judgement of the designer are appropriate, in order to properly size, configure and design that system and to ensure compliance with building and safety code requirements.

#### Essential Control Settings

XXXX