

- P1 = System Pump
- P2 = High Temperature Zone Pump
- P3 = Variable Speed Injection Pump
- S1 = Mixed Supply Sensor 071
- S2 = Boiler Supply Sensor 071
- S3,4 = Outdoor Sensor 070
- S5,6,7 = Slab Sensors 072/072
- V1 = Balancing or Globe Valve
- Z1,2 = High Temperature Zone Valves
- Z3,4,5 = Low Temperature Zone Pumps

Concept Drawing

This is only a concept drawing, not an engineered drawing. It is not intended to describe a complete system, nor any particular system. It is up to the system designer to determine the necessary components for and configuration of the particular system being designed, including additional equipment, isolation relays (for loads greater than the control's specified output ratings), and any safety devices which in the judgement of the designer are appropriate, in order to properly size, configure and design that system and to ensure compliance with building and safety code requirements.

System Operation

XXXX

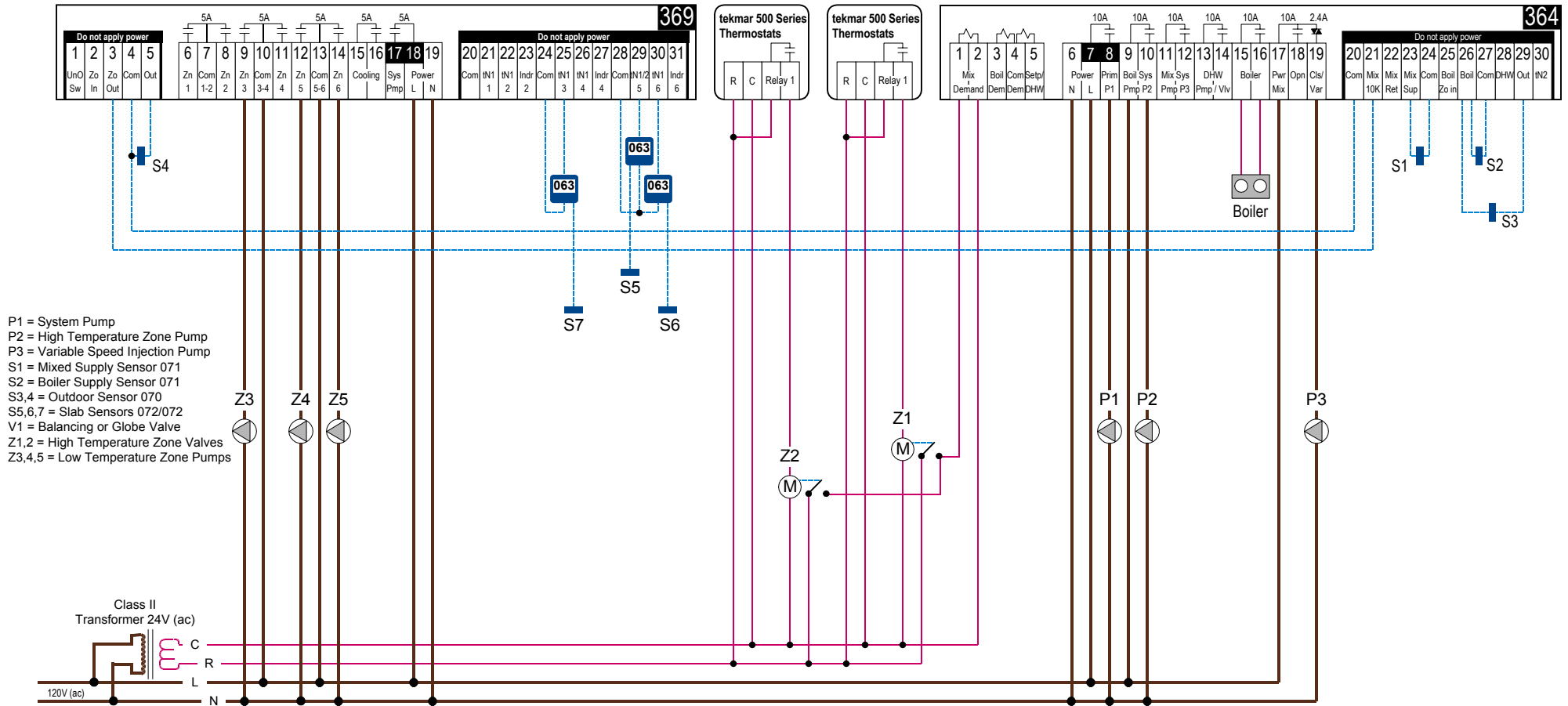

Concept Drawing

This is only a concept drawing, not an engineered drawing. It is not intended to describe a complete system, nor any particular system. It is up to the system designer to determine the necessary components for and configuration of the particular system being designed, including additional equipment, isolation relays (for loads greater than the control's specified output ratings), and any safety devices which in the judgement of the designer are appropriate, in order to properly size, configure and design that system and to ensure compliance with building and safety code requirements.

Essential Control Settings

XXXX