

- A1 = DHW Aquastat
- P1 = Primary System Pump
- P2 = DHW Pump
- P3 = Variable Speed Injection Pump
- P4 = Mixed System Pump
- R1...R3 = Relay 003
- S1 = Boiler Supply Sensor 071
- S2, S4 = Outdoor Sensor 070
- S3 = Mixed Supply Sensor 071
- S5 = Boiler Return Sensor 071
- S6, S7 = Slab Sensor 072/073/078
- T1 = tekmar Thermostat 510
- T2 = tekmar Thermostat 511
- T3 = tekmar Thermostat 512
- V1 = Balancing Valve or Globe Valve
- V2 = Balancing Valve or Pressure Bypass Valve
- Z1...Z3 = Zone Valve

### Concept Drawing

This is only a concept drawing, not an engineered drawing. It is not intended to describe a complete system, nor any particular system. It is up to the system designer to determine the necessary components for and configuration of the particular system being designed, including additional equipment, isolation relays (for loads greater than the control's specified output ratings), and any safety devices which in the judgement of the designer are appropriate, in order to properly size, configure and design that system and to ensure compliance with building and safety code requirements.

### System Operation

XXXX

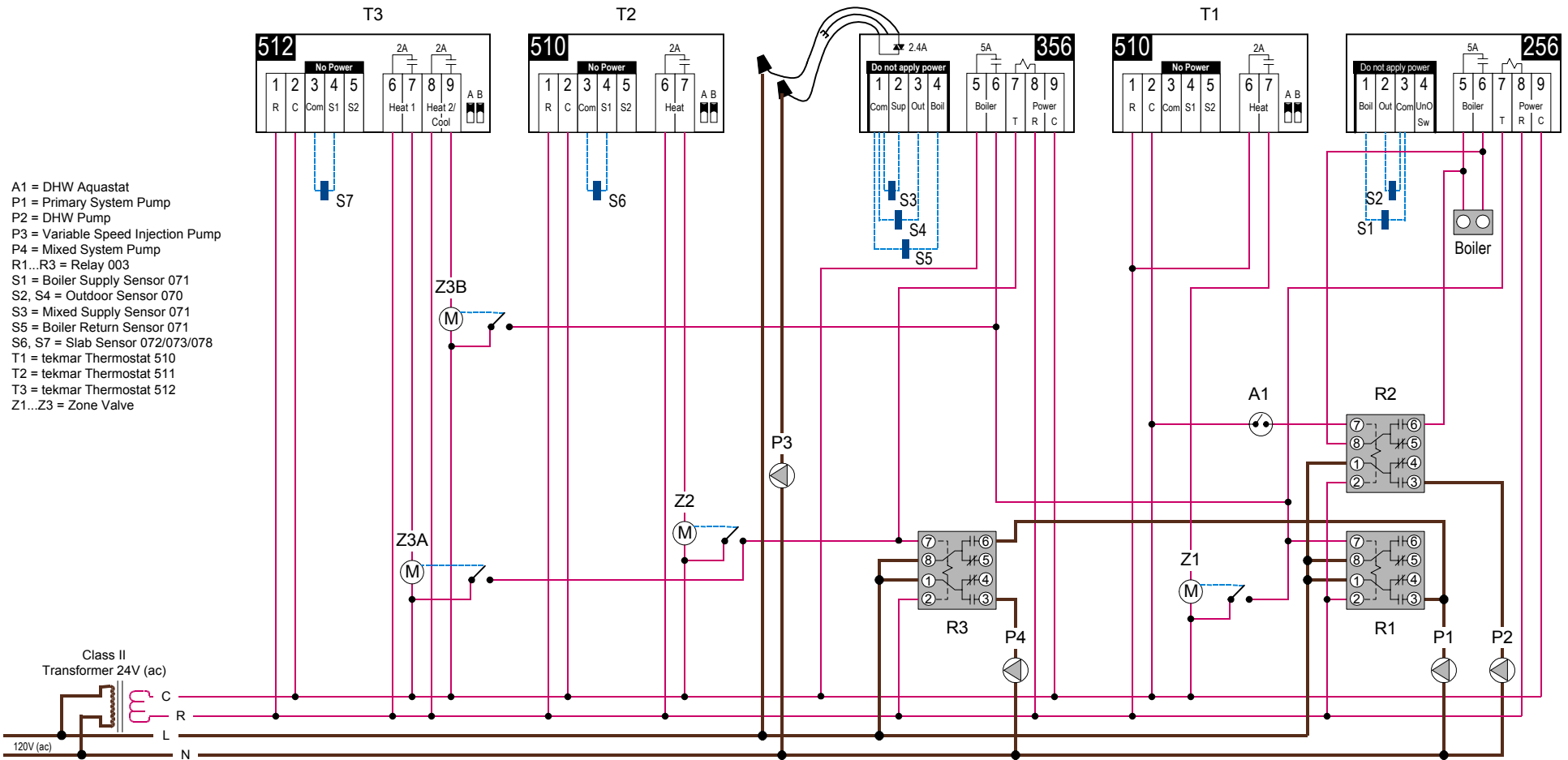

### Concept Drawing

This is only a concept drawing, not an engineered drawing. It is not intended to describe a complete system, nor any particular system. It is up to the system designer to determine the necessary components for and configuration of the particular system being designed, including additional equipment, isolation relays (for loads greater than the control's specified output ratings), and any safety devices which in the judgement of the designer are appropriate, in order to properly size, configure and design that system and to ensure compliance with building and safety code requirements.

### Essential Control Settings

XXXX